

# YIMBY Law

57 Post St, Suite 908  
San Francisco, CA 94104  
[hello@yimbylaw.org](mailto:hello@yimbylaw.org)



YIMBY LAW

---

12/6/2022

Alameda Planning Board  
2263 Santa Clara Avenue  
Alameda, CA 94501

[nmcpeak@alamedaca.gov](mailto:nmcpeak@alamedaca.gov)  
Via Email

Re: 2015 Grand Street  
PLN22-0127

Dear Alameda Planning Board,

YIMBY Law is a 501(c)3 non-profit corporation, whose mission is to increase the accessibility and affordability of housing in California. YIMBY Law sues municipalities when they fail to comply with state housing laws, including the Housing Accountability Act (HAA). As you know, the Planning Board has an obligation to abide by all relevant state housing laws when evaluating the above captioned proposal, including the HAA. Should the City fail to follow the law, YIMBY Law will not hesitate to file suit to ensure that the law is enforced.

The project consists of fourteen multi-family buildings with between four and nine units in each building for a total of 90 townhome units. Four units will be affordable at the Very Low Income level, five at the Low Income level, and 6 at the Moderate Income level.

California Government Code § 65589.5, the Housing Accountability Act, prohibits localities from denying housing development projects that are compliant with the locality's zoning ordinance or general plan at the time the application was deemed complete, unless the locality can make findings that the proposed housing development would be a threat to public health and safety.

The above captioned proposal is zoning compliant and general plan compliant, therefore, your local agency must approve the application, or else make findings to the effect that the proposed project would have an adverse impact on public health and safety, as described above. Should the City fail to comply with the law, YIMBY Law will not hesitate to take legal action to ensure that the law is enforced.

I am signing this letter both in my capacity as the Executive Director of YIMBY Law, and as a resident of California who is affected by the shortage of housing in our state.

Sincerely,

*Sonja Trauss*

Sonja Trauss  
Executive Director  
YIMBY Law

---

**From:** Hank Lindemann [mailto:hankli@comcast.net]  
**Sent:** Wednesday, December 7, 2022 12:07 AM  
**To:** David Sablan <DSablan@alamedaca.gov>  
**Cc:** Hank Lindemann <hankli@comcast.net>  
**Subject:** [EXTERNAL] 2015 Grand Street - The Pennsoil Building and Tankfarm Property

Mimecast Attachment Protection has deemed this file to be safe, but always exercise caution when opening files.

---

Dear Mr. Sablan,

I am a neighbor in the area of 2015 and just received your letter yesterday afternoon. I have voiced a few thoughts on the property and general feeling about over developing the Island. I have attached a letter with my thoughts and feedback not just to this ambitious project but all the new projects that are all about to come on line at once.

Please include my subdued letter for inclusion in the meeting records.

Respectfully,

Henry Lindemann

Sent from [Mail](#) for Windows

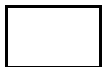

Virus-free [www.avg.com](http://www.avg.com)

Henry Lindemann      [hankli@comcast.net](mailto:hankli@comcast.net)      1817 Grand Street  
Phone: (510) 522-3290      Cell: (510) 774-6548      Alameda, CA 94501

---

December 7, 2022

Attn: Parking Payment Assistant Service  
City of Alameda Planning, Building & Transportation Department  
2263 Santa Clara, Rm. 190  
Alameda, CA 94501

Re: 2015 Grand Street Condominiums at Former Pennsoil Product Plant and Tank-farm Site

Dear Planning Board,

I am not surprised by the public hearing development that the City is planning at the old Pennsoil site at Grand and Clement. After careful review of the plans I see that this project has been in the works for some time and the fact that the public is being notified a week ahead of the project consideration is no surprise. Additionally, in this age of Zoom Agendas coming to popularity by public office during Covid, it is also not surprising that the public is kept at arms length on these controversial projects. I am upset by the fact that this is the first I have heard of 90 condos going up in what used to be single family neighborhoods, this just happens to be my neighborhood.

I suppose that any comments and concerns are water over the dam at this point as the plans are virtually complete and already have been blessed to this point. I do feel however that as a life time resident and going back 3 generations here in Alameda, that I am probably not alone in my following thoughts:

There are too many units for the neighborhood as it was before all the present mega-projects on Clement and Buena Vista. I have no illusion there are more to come and they are at the cost of those that live here, commute here and endure the thousands of new residents and the new traffic.

These units are all replacing zoning that used to be places of business and employment for people who lived here. Zoning is changed and our city has traded work and industry for high density residential and corporate development.

I also see and anticipate traffic above and beyond what we were seeing pre-pandemic. Traffic is back and it is getting increasingly harder to get to work and back home during daylight hours. I see only traffic changes in terms of constraints and fancy non-sustainable neckdowns, traffic aids and gridlock design which restricts freedom of movement. More high density build without new bridges or ingress and egress solutions is poor planning for those who call Alameda home. I am not seeing the solutions being paid for by those doing the developing and it does not feel equitable that we suffer gridlock and the infrastructure expense long after the development is here and the money is gone. It will all look fancy until we have to sustain the maintenance.

90 Units, 180 new cars, 45'- 60' fancy box structures in two story neighborhoods, new extensive infrastructure needs, traffic, construction traffic, noise, narrow streets, limited parking, Clement is the new truck route and is also narrowed by bike lanes as wide as the street with fancy appurtenances. I watch full size grocery and fuel trucks trying to navigate the new traffic constraints, it is not pretty.

In summary, I don't feel more is better. I certainly don't think it will be anymore affordable the more we have. At some point hope I will stand with our leaders that can say why, no, or not so much.

Respectfully,

Henry C. Lindemann

## Nancy McPeak

---

**From:** David Sablan  
**Sent:** Thursday, December 8, 2022 10:29 AM  
**To:** Nancy McPeak  
**Cc:** Andrew Thomas; Allen Tai  
**Subject:** FW: [EXTERNAL] Public Comments for PLN22-0127 - 2015 Grand St

Hi Nancy,

Got this public comment for 2015 Grand Street, please forward to the Planning Board and add it to the public comments. Thanks.

-David

**From:** Tony Martin-Vegue [mailto:tony.martinvegue@gmail.com]  
**Sent:** Thursday, December 8, 2022 9:29 AM  
**To:** David Sablan <DSablan@alamedaca.gov>  
**Subject:** [EXTERNAL] Public Comments for PLN22-0127 - 2015 Grand St

Hi Planning Board,

Please see my public comments below for PLN22-0127 - 2015 Grand St.

- Currently, there are no sidewalks on Grand St between Fortman and Eagle, on both sides of the street. It creates a significant safety issue for pedestrians because they must walk in the street. The safety issue is even worse for people in wheelchairs and people pushing strollers. I've flagged this issue many times over the last several years to City officials, and the response I've always received is that the developer that improves the old Penzoil site will build sidewalks. Looking at the plan, it appears that there is only a plan to build sidewalks on the Penzoil side, leaving the other side of Grand undeveloped. Any plan to develop the Penzoil site needs to include sidewalks on both sides of Grand.
- There should be a public playground or open space in the plan.
- I don't think a 4-way stop at Grand and Clement is sufficient to ensure pedestrian safety. I would like to see a study on how this development will increase traffic in this area and whether a stop light is needed sooner rather than later.

Thank you,  
Tony Martin-Vegue

## Nancy McPeak

---

**From:** Christopher Buckley <cbuckleyaicp@att.net>  
**Sent:** Sunday, December 11, 2022 11:46 PM  
**To:** Ronald Curtis; Alan Teague; Asheshh Saheba; Teresa Ruiz; Hanson Hom; Xiomara Cisneros; Diana Ariza  
**Cc:** Andrew Thomas; Allen Tai; David Sablan; Erin Smith; Jesse Barajas; Nancy McPeak; Erin Garcia  
**Subject:** [EXTERNAL] Subject: PLN 22-0127--2015 Grand Street (Item 7-A on Planning Board's December 12, 2022 agenda)– Street Trees  
**Attachments:** We sent you safe versions of your files; 2010MSTP.Vol2Fnl.pdf

Mimecast Attachment Protection has deemed this file to be safe, but always exercise caution when opening files.

---

Dear Planning Board members:

It is good that this project is moving forward, especially with completion of the long-awaited Clement Avenue extension.

The City's Master Street Tree Plan (MSTP) designates Grand Street and Clement Avenue as "Major Streets", each with special designated tree species to give each street a distinct character. The species designation for Grand Street are Red Maple (*Acer rubrum*), Sugar Maple (*A. saccharum*), Black Maple (*A. nigrum*), Scarlet Oak (*Quercus coccinea*) and Southern Red Oak (*Q. falcata*). The species designated for Clement Avenue are "Columbia" London Plane (*Platanus acerifolia* 'Columbia') and Brisbane Box (*Lophostemon confertus*). Volume 2 of the MSTP is attached. See page 12 (pdf p. 13) for Grand Street and pp. 26-27 (pdf pp.27-28) for Clement Avenue.

The project plans are not yet sufficiently developed to show tree species for specific locations. **I therefore request the Planning Board add the following text to Condition 77 of the Draft Resolution (Exhibit 5):**

*The street tree species for Grand Street and Clement Avenue shall conform with the species set forth in the Master Street Tree Plan, which designates various species of Maples (*Acer*) and Oaks (*Quercus*) for Grand Street and 'Columbia' London Plane (*Platanus acerifolia* 'Columbia') and Brisbane Box (*Lophostemon confertus*) for Clement Avenue.*

Note: Columbia London Plane and Brisbane Box are not currently shown on the project's street tree species list and should therefore be added.

I also recommend as conditions of approval:

- 1. Provide street trees on the west side of Grand Street between Ellen Craig and Clement Avenues.** No street trees are proposed here due apparently to the overhead high-voltage lines. But my understanding is that these lines will be undergrounded, except for the ca. 110 KV lines at the tops of the poles, which appear to be at least 50 feet above grade, which is high enough to accommodate MSTP's maples and oaks. Street tree planting under 110 KV lines where other high-voltage lines have been undergrounded can be seen elsewhere in Alameda, such as along the north side of Clement Avenue between Lafayette and Willow Streets. A type of maple with a wider spread than the "Columnaire" Red Maple shown on the plans (which has a tall, narrow growth form) would perform better under the 110 KV lines. "October glory" Red Maple is one possibility.

2. **Provide a 4' x 6' minimum planting space for each street tree.** Where the proposed planting strips are less than 4' wide, the sidewalk should meander to provide 4' x 6' minimum planting space as is already showing for some sidewalk sections for this project and is used on Constitution Way between Lincoln and Eagle Avenues, as well as other Alameda locations.

3. **Use a combination of London Plane and Brisbane Box along Clement Avenue,** based on the species alternation patterns shown on Page 9 (pdf p. 10) of the MSTP, Volume 2.

4. **Provide at least two additional street trees on the south side of Clement Avenue between Hibbard and Grand Streets.** Only three trees are proposed, but there appears to be room for two or three more.

Please contact me at 510-523-0411 if you would like to discuss these comments.

Sincerely,

Christopher Buckley

cc: Andrew Thomas, Allen Tai and David Sablan (Planning, Building and Transportation)  
Erin Smith and Jesse Barajas (Public Works)

# ALAMEDA MASTER STREET TREE PLAN





## **CITY COUNCIL**

Beverly Johnson, Mayor  
Doug De Haan, Vice Mayor  
Lena Tam, Councilmember  
Marie Gilmore, Councilmember  
Frank Matarrese, Councilmember

## **CITY STAFF**

Matthew Naclerio, Public Works Director  
Barbara Hawkins, Project Manager and City Engineer, Public Works Department  
Shilpa Patel, Junior Engineer, Public Works Department  
Todd Williams, Public Works Supervisor, Public Works Department

## **CONSULTANTS**

Charlie Lanfranco, Tanaka Design Group, San Francisco  
Melanie Gentles, Certified Arborist  
Zoë Lonergan, Book Cover and Document Designer



Improving our urban forest is no simple task, and requires the ideas, time, and expertise of many people. This project is the result of extensive collaboration and teamwork among those within and outside Alameda's urban forest. Special thanks go to the residents of the Alameda urban forest who enthusiastically attended meetings and provided feedback, so that this plan could reflect their vision for the forest in which they live. We would particularly like to thank Chris Buckley for his time, dedication and draft reviews.

**THE CITY OF ALAMEDA'S MASTER STREET TREE PLAN  
VOLUME 2**

<b>CHAPTER 1 / PLANTING PALETTES</b>	<b>6</b>
1.0 / How to Use the Planting Palettes	7
1.1 / Major Streets of Alameda	8
1.2 / Neighborhoods of Alameda	52
1.3 / Business Districts of Alameda	79
<b>CHAPTER 2 / ABORICULTURAL BEST PRACTICES</b>	<b>80</b>
2.0 / New Tree Plantings	82
2.1 / Buying High-Quality Trees	86
2.2 / Pruning Young Trees	88
2.3 / Pruning Mature Trees	91
2.4 / Mature Tree Care	96
2.5 / Proper Mulching Technique	101
2.6 / Insects and Diseases	103
2.7 / Protecting Trees Under Construction	107
<b>CHAPTER 3 / EDUCATION</b>	<b>112</b>
3.0 / Community Outreach and Education	113
<b>APPENDICES</b>	<b>120</b>
Appendix 1 / Street Tree Planting and Staking Specifications	121
Appendix 2 / Required Distances Between City Infrastructure and Trees	126
Appendix 3 / Protection of Important Nesting Habitat	127
Appendix 4 / City Of Alameda - Special Planting Zone Map	129

<b>GLOSSARY</b>	130
<b>BIBLIOGRAPHY</b>	132
<b>i. TREE MATRIX</b>	136
<b>ii. DEFINITION OF TERMS IN THE TREE MATRIX</b>	146

**PLANTING PALETTES**

# **CHAPTER 1**

## 1.0 / HOW TO USE THE PLANTING PALETTES

As an essential part of effectively using this MSTP, tree selection criteria are discussed with an emphasis on choosing the right tree for the right place. Such decisions are genuine design problems to be solved, and instead of using a subjective approach (“What’s my favorite tree?”), an objective process is presented. Specifically, trees can be considered to have three major categories of selection criteria—visual (aesthetic), functional (utilitarian), and viability (soil or ecological). These factors are interrelated and one or more may be dominant given the particular planting situation, but all three must be considered.

To employ these criteria, a developer, city manager, or resident selects a tree species for a particular street or neighborhood by using the appropriate planting palette and the Tree Selection Matrix (located at the end of this MSTP). The appropriate tree species should be procured, planted, and established as set out in Tree Planting Guidelines in Volume 2 Chapter 2, Arboricultural Best Practices. The Tree Matrix will be updated every five years as experimental trees are evaluated, poorly performing species are removed and new species are recommended for inclusion.

## 1.1 / MAJOR STREETS OF ALAMEDA

Streets leading into Alameda and heavily traveled corridors crossing through town have been identified as major thoroughways of the city. They are treated separately from Alameda's neighborhoods because of their high visibility and importance to the city's functions, character, and atmosphere. Each major street has a specific tree palette. In general, tree species were assigned to create a uniform planting, which will provide continuity through a variety of land uses and reinforce the street's identity and the street's place in the hierarchy of Alameda's streets. Refer to the following individual street descriptions for specific recommendations. Each description contains a visual analysis of existing boulevard characteristics, existing trees, and planting recommendations. A location map accompanies each boulevard description. Changes to the tree selections for major streets must be approved by the planning board.

### GOALS FOR THE TREES ALONG MAJOR STREETS

- Protect healthy trees while providing for infrastructure stability and public safety.
- Replant new trees where existing trees cannot be safely retained.
- Proactively pre-plant trees in vacant sites.
- Plant the largest species appropriate for the site.
- Perform tree removals in phases to retain an acceptable level of canopy cover.
- Where feasible, enlarge planting areas.
- Provide wildlife habitat.
- Foster neighborhood transition plans and communication regarding infrastructure conflicts.

### PARAMETERS USED IN SELECTING TREE SPECIES FOR MAJOR STREETS

1. Street trees are used to emphasize the continuity of major streets and to give each street a distinct identity. For example, the main island's five central east/west major streets (Encinal, Central, Santa Clara, Lincoln, and Buena Vista Avenues) have similar development patterns along their frontages, but can be individualized with street trees using the following general schemes:

**Encinal Avenue:** Mixed deciduous, such as maple trees.

**Central Avenue:** Single-species London Plane trees.

**Santa Clara Avenue:** Mixed broadleaf evergreens.

**Lincoln Avenue:** Mixed broadleaf evergreens and deciduous.

**Buena Vista Avenue:** Mixed deciduous of similar appearance such as elm trees and silver lindens.

2. In most cases, use a unique species palette with a maximum of six species (not including medians) for the entire length of each major street. In developing the street species palette, it is important to continue existing distinctive species plantings, such as the London plane trees on Central, except where the species are undesirable, as with the bottle trees on Lincoln Ave or the Liquidambars on Gibbons Drive. In the few cases where a street is divided into sections of radically different character or environmental conditions, such as Grand Street north and south of the lagoon, different palettes may be used for each section, provided

\*Tree species have been selected from the tree matrix at the end of the MSTP



at least one stronger species is used in all sections to maintain an element of continuity throughout.

**3.** Where possible, select trees with ultimate height of at least 40 feet for streets with width of 36' or more. Though there are many site constraints, tree plantings should maximize the height and canopy spread of the tree planted. Conflicts with traffic lights, other infrastructure or major architectural elements may require planting smaller trees. For the streets with widths 36' or less conflicts with overhead high voltage wires require that plantings should be short stature. For streets wider than 36' a balance is needed between maximizing street tree canopy, the placement of trees to minimize utility line and infrastructure conflict enhancing neighborhood character.

**4.** Incorporate into the palette any large tree species that are currently used frequently, except where the existing trees are undesirable. Distribute different species as evenly as possible along the entire length of the street to maintain continuity. Even distribution is important, but strict symmetry is not necessary. A repeating pattern that allows for variations in planting spaces on both sides of the street is optimal. Possible patterns include:

**Pairs:** 2a-2b-2c-2a, (2a = 2 of tree species a), with two trees from each recommended species planted along each side of the street. This pattern accommodates variations.

**Pyramid:** 1a, 2b, 3c, 2b, 1a, where 'a' has the largest mature size of the three planted species.

**Alternating:** 1a, 1b, 1a, 1b, 1c, 1b, 1c, 1a, 1c, 1a, for a random alternating pattern.

In situations where entire blocks may be planted at once, there exists the opportunity for implementing one of the above patterns of tree planting. In locations where several planting sites exist in a row, trees should be used with equal frequency at a minimum ratio of 1:3. The goal is to plant no more than four instances of the same species consecutively before changing to an alternate species.

**5.** Select trees from the Tree Matrix that are particularly suitable for major streets. Selected trees should have a local track record that demonstrates their long-term reliability. However, trees that appear promising but have not yet established such a track record can still be selected for “limited use” if:

- a.** Such trees do not account for more than 15% of the planting sites along the entire street or within a 1200-foot segment of the street (approximately three blocks); and
- b.** The “limited use” trees are needed to serve a specific design function that trees with established track records are not able to serve. Examples of such design functions include trees that are needed to maintain visual continuity with existing trees where the existing trees are undesirable and where none of the trees with established track records can serve this function.

See Table 3.0 for a list of recommended trees for major streets, including the trees for “limited use.”

**6.** For medians less than 6’ trees are not to be planted. Each median should require specific designs that are well coordinated with trees selected for sidewalk planting and sight distance. Site size must be considered before selecting a species.

**7.** Maximize the potential of constrained planting areas. Where existing sidewalk planting strips, tree wells, or other curbside planting areas are not wide enough for large trees, either:

- a.** Widen the curbside planting area into the sidewalk by reducing the sidewalk width to a 42-inch minimum sidewalk where possible, but maintain a greater width in high pedestrian areas, or
- b.** Plant the trees along the back of the sidewalk with approval from the property owner but still within the public right of way. Where space is limited, tree cutouts along the back of the sidewalk are acceptable.

**8.** For streets close to the shoreline with bay mud fill conditions, the major street recommendations focus on trees generally considered well suited to shorelines with high water tables and muddy soils.

**9.** Consideration should also be given to adjacent buildings in the selection of species. In general, columnar or pyramidal trees should be favored in front of multi-story or commercial buildings, especially those with shallow setbacks. Conversely, broad spreading trees could be favored in front of one-story buildings with deep setbacks, especially low-step buildings, such as bungalows. There may be street sections where street trees should not be used. A list of these locations should be identified by the Planning Board.

**Table 1.0 / Recommended List of Trees for Major Streets**

<p><i>Acer nigrum</i> — black maple.</p> <p><i>Acer rubrum</i> — red maple. ‘October Glory’, ‘Brandywine’, and possibly other varieties (but not ‘Red Sunset’ or ‘Morgan’).</p> <p><i>Acer saccharum</i> — sugar maple. ‘Commemoration’ and possibly other varieties (but not ‘Green Mountain’).</p> <p><i>Corymbia ficifolia</i> — red-flowering gum.</p> <p><b>*Fagus sylvatica</b> — European beech. Use on major streets with sufficient planting space, and only as a substitute for ‘<i>Alnus rhombifolia</i>’ (white alder) where a tree similar to the white alder is desired.</p> <p><i>Ginkgo biloba</i> — maidenhair tree. ‘Fairmount’, ‘Saratoga’, and possibly other varieties, but not ‘Autumn Gold’.</p> <p><b>*Gymnocladus dioica</b> ‘Espresso’ — seedless Kentucky coffee tree.</p> <p><i>Koelreuteria bipinnata</i> — Chinese flame tree</p> <p><b>*Lagerstroemia indica</b> x <i>L. fauriei</i> — Crape Myrtle. ‘Tuscarora’ and possibly other varieties. Use only as accent trees along Park Street and Webster Street.</p> <p><i>Magnolia grandiflora</i> — southern magnolia. ‘Russett’ and possibly other varieties. Use only in the largest planting spaces and not near drain inlets.</p> <p><i>Metrosideros excelsus</i> — New Zealand Christmas tree. Use only in large planting spaces.</p> <p><i>Pistacia chinensis</i> — Chinese pistache. ‘Keith Davey’ variety.</p> <p><i>Platanus acerifolia</i> — London plane tree. ‘Columbia’ and ‘Yarwood’ varieties.</p> <p><i>Pyrus calleryana</i> — flowering pear. ‘Aristocrat’ and possibly other varieties (but not ‘Bradford’ or other varieties with a strong tendency to develop multiple V-crotches). Use only where currently growing such as along Webster Street.</p> <p><i>Quercus coccinea</i> — scarlet oak.</p> <p><b>*Quercus falcata</b> — southern red oak.</p> <p><b>*Quercus virginiana</b> — southern live oak.</p> <p><i>Tilia tomentosa</i> — silver linden.</p> <p><i>Tristania conferta</i> — Brisbane box.</p> <p><b>*Ulmus</b> spp. — various American and hybrid elms. <b>*‘Accolade’</b>, <b>*‘Commendation’</b>, <b>‘Frontier’</b>, <b>*‘Jefferson’</b>, <b>*‘New Harmony’</b>, <b>*‘Patriot’</b>, <b>‘Princeton’</b>, <b>*‘Triumph’</b>, <b>*‘Washington’</b>, and possibly other varieties.</p> <p><b>**Washingtonia robusta</b> — Mexican fan palm. Use only in special situations, such as on Shoreline Drive or Eighth Street between Central and Portola.</p>
---

*\*Trees that have not yet established a local track record and which are, therefore, designated only for “limited use.”*

*\*\*Trees for special use only. See specific comments for each tree.*

## ATLANTIC AVENUE & CLEMENT AVENUE

The oldest portion of Atlantic Avenue is at its western end. It is characterized by former naval air station housing, low-cost housing built in the 1940s to 1950s, a school site, and a wide railroad easement with chain link fencing along the south side. Buildings date from prior to 1909 until 1954 near the intersection with Webster Street.

Across Main Street, the new residential development neighborhood Bay Port is nearly completed. On this side of the street, the developer has planted a selection of London plane trees alternating with locust trees planted behind the sidewalk. These trees provide a wonderful pedestrian passage along the housing development and toward the industrial and naval section of the street. Toward Webster Street along the College of Alameda there are new London plane trees connecting the development street trees and the large trees on the college campus. Overall, the street image is no longer uneven and chaotic. The street image is highly split between the northern tree plantings and the vacant, though planned, southern side. With a continued commitment by the City of Alameda to complete the broad street plantings on the south side of the street, a beautiful, lush streetscape can be expanded along this section of the street.

From Webster to Constitution Way, Atlantic Avenue was completely landscaped in the late 1980s with dense street tree planting that reinforces the circulation patterns there. These trees are now maturing well and, though still juvenile, can be expected to create a mature tree canopy over the next 30 years. The development consists of one- and two-story commercial buildings.

Beyond Constitution to Sherman Street, a uniform streetscape image is created by dense street tree plantings that include medians. Chain-link fencing combines with street trees to screen the commercial-industrial uses built in the 1980s. Integrated landscape plantings reinforce the sense of identity. This pattern continues past office development sites, with entries emphasized by accent trees, until Atlantic becomes Sherman Street at the eastern end.

While mentioned in the 1989 Master Plan, Clement Avenue is not a significant street on its own. For this reason Atlantic Avenue and Clement Avenue are to be treated as the same street, since they will eventually be connected as the city's major waterfront arterial. Clement Avenue is currently an industrial district with no planting strips. Most of Clement Avenue presents a special challenge because the six-foot sidewalks with many zero-setback buildings are too narrow for street trees. A further complication is high voltage wires on both sides of the street. To plant street trees on Clement, it will likely be necessary to either: (i) widen the sidewalks; (ii) plant trees in the parking lane; and/or (iii) plant trees and cutouts on the back of the sidewalk (but still in the right-of-way), as has been done along the Alameda Marina frontage. For these reasons, no detailed review or recommendations are made for Clement Avenue at this time. However, as development continues throughout the area, landscape setbacks that allow for street-lined tree corridors should be encouraged.

#### **Existing Trees**

*Eucalyptus nicholii* - willow-leaved peppermint

*Ceratonia siliqua* - carob

*Liquidambar styraciflua* - sweetgum

#### **Planting Recommendations:**

*Tristania conferta* - Brisbane box (Not under high voltage lines).

*Platanus acerifolia* 'Columbia' and 'Yarwood' - London plane tree (not appropriate for Clement Avenue until redevelopment guidelines are implemented)

#### **Design Recommendations**

**Atlantic Avenue:** Complete a broad street planting between Main Street and Webster Street on the south side of the street. Connect to the new street planting promenade along Main Street.

**Clement Avenue:** Plant street trees where possible to increase urban forest canopy.

## **BROADWAY**

Broadway is an important north/south corridor on the eastern side of Alameda, with four lanes for most of its length. It is characterized by mostly single-family residences built from approximately the 1890s to the 1920s, along with a few multi-family units built in the 1940s and 1950s; some buildings even date from prior to 1872.

Broadway has a strong planting palette of uniform street trees. It has one area of commercial and high-density housing at Central Avenue; after Central, Broadway reverts back to its former residential pattern. At Tilden Way, Broadway crosses the railroad and land uses become industrial and commercial. It terminates at Blanding Avenue at a one-story commercial center built in the 1980s and 1990s. Broadway is representative of the west-end palette with many middle-aged trees, and the street appears to have three distinct segments in terms of tree consistency. Broadway is most consistent with its tree canopy north of Santa Clara, and then less so until Encinal, and least of all south of Encinal. In its prime, Broadway is a signature Alameda street with marked complexity in both age and species selection.

### **Existing trees**

*Fraxinus velutina* var. *glabra* - Modesto ash

### **Planting Recommendations**

\**Gymnocladus dioica* 'Espresso' - seedless Kentucky coffee tree

*Acer rubrum* - red maple. 'October Glory', 'Brandywine', and possibly other varieties (but not 'Red Sunset' or 'Morgan'). Do not use 'Brandywine' under high voltage lines

*Ulmus* 'Frontier' and 'Princeton' - frontier hybrid elm and Princeton American elm

### **Design Recommendations**

Since ash should not be continued due to the borer threat, include trees such as seedless Kentucky Coffee Tree to differentiate Broadway from High Street, which is also dominated by Modesto ash that will require removal. Improve planting consistency south of Santa Clara Avenue. Prioritize planting in available planting spots. Broadway should be considered a priority street. Priority actions should include removing trees that are in decline and planting new ones.

\*Experimental or trial.

**BUENA VISTA AVENUE**

Buena Vista Avenue is a major east/west boulevard that travels along the north side of the city. At its western end, Buena Vista is made up of high-density multi-family residences, two- to four-story buildings built in the 1950s and 1960s. There are young and mature street trees of various species with common landscape areas surrounding the buildings. Many young trees have been planted along this stretch of street just east of Webster, and with careful maintenance, they will mature into a nice street canopy. Beyond Webster, the newly planted young trees are replaced by dense plantings of mature, large-stature street trees among single-story residences dating approximately from the late 1870s to the early 1900s, and two-story multi-family buildings built in the 1970s. The image changes towards the east as the quantity of mature street trees varies.

A different atmosphere altogether begins at the Sherman Street industrial complex and railway along the north side with Buena Vista Park to the south. This industrial complex is being developed as an adaptive reuse project, and future improvements will likely include street tree plantings along the north side of the street. Between Ohlone and Hibbard, new residential development has added a selection of fine street trees that will mature nicely with conscientious pruning and maintenance. This continues for several blocks before reverting back to mostly 1870s to early 1900s single-family houses to 1950s multi-family residential. Toward its eastern end, Buena Vista Avenue contains bungalows built between 1910 and 1925. Beyond Park Street, Buena Vista becomes a residential collector street. All along Buena Vista Avenue, the street trees are not as bleak as they were in the last Master Plan, and these trees should mature and fill out to create a beautiful streetscape.

**Existing Trees**

*Fraxinus holotricha* 'Moraine' - Moraine ash

*Liriodendron tulipifera* - tuliptree

**Planting Recommendations**

*Tilia tomentosa* - silver linden

*Ulmus* hybrids and cultivars - various American and hybrid elms including 'Accolade', 'Commendation', 'Jefferson', 'New Harmony', 'Patriot', 'Triumph', 'Washington', 'Frontier' and 'Princeton'

**Design Recommendations**

As the renovation and adaptive use project is completed along Buena Vista at Sherman Street in the industrial complex, street trees must be included in the development plans to connect the street canopy along the entire length of the street.



**CENTRAL AVENUE**

Central Avenue is a major boulevard without medians, with primarily four lanes. It has the most consistent mature street tree plantings that exist today in Alameda. Central Avenue presents a very striking, harmonious streetscape dominated by large-stature London plane trees, with sidewalks on both sides of the street and a strong residential character. The homes range in age from approximately 1883 to 1910, predominantly from the 1890s and later. Central bounds the north ends of the Park Avenue and Burbank-Portola Heritage Areas, with street trees forming an archway over the street.

Central Avenue has been and continues to be a major east/west arterial through the city. At the western end of Central, beyond the Webster Street business district, there are varied species and fewer street trees planted, especially on the south side. This area was largely built during the 1940s to 1950s, except for high-density housing built in the 1970s along the marina side, toward the south. West of Third Street, there are no street trees and the street loses its uniform image, terminating with the naval air station storage yards at Main Street. Traveling eastward from Webster, Central Avenue is strongly residential, constructed during the late 1880s to 1909, the 1920s, and the 1940s, with one-story corner markets and other local services occasionally interspersed. Near Park Avenue there are a few commercial establishments. Beyond Park, Central continues as a uniformly residential street where established street trees prevail. Beyond Fernside Boulevard, the street image changes slightly because the residences were built in the 1950s, and because of variations in street tree planting design and species.

**Existing Trees**

*Platanus acerifolia* 'Columbia' and 'Yarwood'

- London plane tree

**Planting Recommendations**

*Platanus acerifolia* 'Columbia' and 'Yarwood'

- London plane tree

**Design Recommendation**

Continue strong single-species plantings from Grand Avenue out to the Encinal High School where there is a culvert with the sewer line under the sidewalk. Proactively remove older plane trees that are in decline and replace with younger plane trees and proactively replant existing vacant planting sites. This will maintain sustainable canopy coverage and prevent removals in large numbers when the trees begin to decline severely and become safety concerns.

**DOOLITTLE DRIVE**

Doolittle Drive is an important connector route from southern Alameda to the Nimitz Freeway to the east. It is an open, spacious roadway adjacent to the Alameda Municipal Golf Courses. The golf courses and clubhouse date from approximately 1926 and later. The northern right-of-way screens the former City dump beyond, established in approximately 1961. Island Drive, the main boulevard into Bay Farm Island, intersects Doolittle Drive's western end just before the Bay Farm Island Bridge; Doolittle crosses the Oakland-Alameda border, has two lanes, continues along the San Leandro Bay, and is very open and spacious, affording varied shoreline views. The street seems to borrow its image from the adjacent open, park-like golf course.

**Existing Trees**

*Platanus acerifolia* 'Yarwood' - London plane tree

*Acacia melanoxylon* - black acacia

*Populus nigra* 'Italica' - Lombardy poplar

**Planting Recommendations (south side only)**

*Platanus acerifolia* 'Columbia' and 'Yarwood' - London plane tree

*Tilia tomentosa* - silver linden

*Metrosideros excelsus* - New Zealand Christmas tree

**Design Recommendations**

The existing London plane trees are not doing well. The cause should be determined and if it appears they are unsuitable for this location, the City should plant only silver linden and New Zealand Christmas trees.

## ENCINAL AVENUE

Encinal Avenue is primarily residential, though it is an important east/west boulevard through the city. It has a mixture of different uses, from small businesses to older residential homes. The western portion was built mostly from the 1880s to 1910, with buildings dating as early as 1877; there are also some buildings from the 1930s. Traveling east, the character changes to mostly commercial with single-story corner markets (some from the 1890s) and other local services mixed with two-story residences built in the 1920s and 1930s.

Encinal begins at its intersection with Central Avenue. From Central traveling east, the image of street tree plantings varies. A few large-stature mature trees are spotted among new large-stature trees of various species and size, though these younger London plane trees are beginning to conflict with the overhead power lines. This problem is especially visible between Willow and Walnut. In several places along Encinal, such as at Park across from the Alameda High School, the street loses its consistency as the plantings are discontinuous, and the streetscape consequently loses its identity. This pattern continues to Oak Street, then between Oak Street and Park Avenue the street image changes as land use is devoted to one- and two-story commercial buildings. The street trees in this area have become small-stature trees, and the street is lined with Victorian-style lampposts.

Beyond Park, the pattern reverts to mostly single-family homes built from approximately 1890 to 1910. Along the far eastern alignment of Encinal south of High Street, there is a wide median that is treated like a park, planted with large-stature, mature trees and turf. Though there are not many street trees, the median planting gives a distinct, park-like image to this end of Encinal. Beyond Fernside Boulevard, the image is similar to that of Central Avenue past Fernside, with young street trees planted and homes built in the 1950s to 1960s. The Historic Business Districts, including Station and Versailles, are a highlight of Encinal.

### Existing Trees

*Fraxinus velutina* var. *glabra* - Modesto ash

*Fraxinus oxycarpa* 'Raywood' - Raywood ash

*Fraxinus holotricha* 'Moraine' - Moraine ash

**Planting Recommendations**

*Acer rubrum* - red maple. 'October Glory', 'Brandywine', and possibly other varieties  
\**Gymnocladus dioica* 'Espresso' - seedless Kentucky coffee tree. Pistacia Chinensis  
*Acer Nigrum* and *Tristania Conferta*.

**Design Recommendations**

Priority plantings should occur along Encinal, a beautiful and surprising street with a wonderful mix of residential areas, small businesses, and schools. Do not continue to plant ash trees, due to the borer threat. Instead, use seedless Kentucky coffee trees, combined with other species. Distinct planting strategies should be used to highlight and celebrate the Historic Business Districts.

The two-foot wide sidewalk planting strips along Encinal between High Street and Fernside Boulevard are too narrow to comfortably accommodate large street trees. The median strip in that area may be newly designed with wild grasses, perennial flowers, and dense native low-water ground cover to create a much more complex and rich plant tapestry. Being one of the largest and most unusual medians in the city of Alameda, the Encinal median should be celebrated as a charming neighborhood surprise.

\*Experimental or trial.

## FERNSIDE BOULEVARD

Fernside Boulevard begins at its intersection with Tilden Way, close to the Fruitvale Avenue Bridge. In general, Fernside is made up of one- and two-story residences, built from 1910 to the 1930s. It has some medium- to large-stature street tree plantings that are established, and beyond the High Street intersection there are uniform, dense street tree plantings. The residences here mostly date from 1910 to the 1950s.

This pattern continues around the curve to the southern alignment of Fernside, where single-family housing along the east was built in the 1950s to 1960s with a few multi-family buildings and a school site. The dense uniform London plane trees north of Central change radically at Lincoln Park; from here on, conscientious plantings in vacant planting spots has not continued except for some brand new plantings across from the school south of Encinal. Fernside Boulevard is the easternmost route along the Alameda mainland, and it connects many important streets to the surrounding neighborhoods.

### Existing Trees

#### Tilden Way to High Street:

*Ginkgo biloba* - maidenhair tree

*Fraxinus holotricha* 'Moraine' - Moraine ash

#### High Street to Encinal Avenue:

*Platanus acerifolia* - London plane tree

#### Encinal Avenue to Otis Drive:

*Fraxinus holotricha* 'Moraine' - Moraine ash

### Planting Recommendations

*Platanus acerifolia* 'Columbia' and 'Yarwood' - London plane tree (for planter strips with minimum 5 foot widths)

\**Gymnocladus dioica* 'Espresso' - seedless Kentucky coffee tree

*Tilia tomentosa* - silver linden (especially good for small planting areas)

### Design Recommendations

Connect the continuous dense London plane tree plantings with the newer plantings south of Encinal. Create a clear tree connection from Lincoln Park through

to Fernside Boulevard so that the park can actively spill out onto Fernside, much like it does on High Street. Right now the Fernside park entrance feels like a back entrance, neglecting the Fernside neighborhood. A change in plantings will result in a more equitable park orientation to both sides. The two-foot-wide planting strips along Fernside south of Garfield Avenue and East Shore Drive to Encinal Avenue are too narrow to comfortably accommodate large street trees. Widening the sidewalk into the roadway by at least 2' should be considered at a future time.

\*Experimental or trial.

## GIBBONS DRIVE

The street tree plantings and architecture along Gibbons Drive create a very uniform streetscape image. It is a residential collector street that runs through the neighborhood. Its image is well integrated with its single-family 1920s- and 1930s-era residential atmosphere. Some additional residences were built in the 1950s to 1960s. The large, mature, uniform, and dense *Liquidambar* street tree plantings create a majestic canopy. This magnificent image is further enhanced by the curving nature of the street, which directs attention towards the line of street trees and provides an interesting view along the street. This continuity of character endures throughout the entire length of Gibbons Drive.

### Existing Trees

*Liquidambar styraciflua* - Sweetgum.

### Planting Recommendations

One of the following species should be selected to replace the *Liquidambar* monoculture:

*Acer rubrum* - red maple. 'Brandywine' and possibly other varieties

*Quercus coccinea* - scarlet oak

\**Quercus falcata* - southern red oak

### Design Recommendations and Keys to Transition Success

- *Liquidambar styraciflua* are not recommended as urban street trees. Declining or high risk *Liquidambar* trees should be removed
- Healthy *Liquidambar* trees should be kept as long as possible with community cost sharing, streetscape changes and root pruning
- Initiate phased introduction of proven street tree species
- Provide sufficient planting and rooting space
- Abide by existing 5% annual tree removal rule per block face

Gibbons should be considered a priority street. Gibbons Drive from Versailles Avenue to High Street is lined on both sides with magnificent, mature *Liquidambar styraciflua* (American sweetgum) trees. Several factors make this street the pride of Alameda residents. One is the massive size of this species, combined with the fine foliage and branch canopy it creates for the adjacent homes. The other is



the ambience of maturity, grace, and permanence contributed by trees of this stature. Additionally, tall trees with dense canopies like the *Liquidambar* trees are favored by Cooper's hawks for nesting. Unfortunately, the *Liquidambar* trees are increasingly in decline. The continued maintenance cost of these declining, mature trees will only increase as high risks associated with limb failures increase. The species also destroys pavement, driveways, water mains, and house foundations with aggressive root systems, and drops large quantities of hard seed pods. Even young, this tree has an inherently poor branching structure that allows splitting of the limbs despite excellent pruning.

For these reasons, the *Liquidambar* need to be carefully and systematically removed over the next 20 years to begin the process of establishing a new street canopy. If the trees are not removed and replaced incrementally, then a neighborhood-wide removal will have to take place when all the trees become safety concerns.

The continuity of size and yellow, red, and orange fall colors should be maintained with careful selection of alternative species. It is therefore important to plant the largest possible new trees, selected for not only for their mature size, but also for their fall color. Residents should be educated about the watering and fertilizing practices on adjacent property to encourage successful establishment of the new recommended species palette. Where possible, the tree rooting area should be increased. Planting trees on the home sides of the sidewalk while replacing the sidewalk to the curbside is also a long-term option residents and the City may investigate. The additional rooting space will encourage healthier growing conditions for faster growing and larger mature trees.

\*Experimental or trial.

## GRAND STREET

Grand Street is a north/south boulevard running through the heart of Alameda. Grand Avenue's northern extremity crosses three railroad lines and terminates in a boat ramp into the Alameda Inner Harbor, where it is surrounded by marinas and maritime land uses. At its southern end beyond Otis Drive, development from the 1950s and 1960s created one-story single-family residences until the street reaches the Bay at Shoreline Drive, where there are multi-family buildings. In general, Grand Street is strongly residential in character with a more expansive feeling and scale than many other streets in Alameda. It contains some of the finest examples of Victorian and Edwardian architecture that exist in the city. These buildings mostly date from approximately the late 1880s to 1909, and the earliest were built prior to 1872.

The cohesive streetscape image is a direct result of this architectural predominance in addition to the dense, mostly mature, medium- to large-stature street tree plantings. The architectural continuity is derived from the height, complex ornamentation, and loving protection of the Victorian residences; their setback from the street; and the continuity of the landscape surrounding the buildings. This connection between the residential landscape and the diverse mature street trees reflects the highest standard of streetscape landscaping in the city. While not all residential areas have such extensive street-facing landscape opportunities, the wonderfully complex street plantings of young and mature trees should be used as a template for other streets. South of Santa Clara, the mixture of smaller ornamental trees, evergreens, and broadleaf deciduous trees is simply mesmerizing. Postcards from the early 20th century show a similar planting palette, and the continued success of that planting fashion reveals a method for sustainably cultivating a long-term street tree program.

### Existing trees

#### North of Otis Drive:

*Acer platanoides* - Norway maple

*Pyrus calleryana* 'Bradford' - Bradford pear

*Robinia pseudoacacia* - black locust

**South of Otis Drive:**

*Eucalyptus rudis* - swamp gum

*Corymbia ficifolia* - red-flowering gum

*Eucalyptus nicholii* - willow-leaved peppermint

**Planting Recommendations****North of lagoon:**

*Acer rubrum* - red maple, 'October Glory', 'Brandywine', and possibly other varieties

*Acer nigrum* - black maple

*Acer saccharum* - sugar maple, 'Commemoration' and possibly other varieties (but not 'Green Mountain')

*Quercus coccinea* - scarlet oak

\**Quercus falcata* - southern red oak

**South of lagoon:**

*Corymbia ficifolia* - red-flowering gum

**Design Recommendations**

Extend the planting success from south of Santa Clara to the northern part of Grand Street. The recommendation emphasizes maples north of the lagoon because the maple had been Grand Street's signature tree and significant numbers remain. Maples were also designated for Grand Street in the existing street tree plan. Although slower growing than red maple, sugar maple is included because it and Norway maple were the maples historically used on Grand Street. Norway maple, however, does not perform well in the Bay Area. Black maple is similar to sugar maple, but is faster growing. Scarlet oak and southern red oak are included to provide more diversity of species, but with a maple-like appearance.

The maples and oaks were limited to north of the lagoon because they may not perform well in the fill soil south of the lagoon, especially with the potentially high soil salinity. However, their potential south of the lagoon should be verified. Red-flowering gum was included to provide a large-stature tree south of the lagoon. The maples will perform this function north of the lagoon.

\*Experimental or trial.

## HARBOR BAY PARKWAY

Harbor Bay Parkway forms the entrance into Harbor Bay Business Park, an imposing office, research, and development center at the south end of Bay Farm Island. Development here began in the 1980s and is ongoing, though construction of the Alameda Municipal Golf Courses and their clubhouse, which border much of the north end of Harbor Bay Parkway, began in the 1920s. Harbor Bay Parkway has four lanes with a wide central median along its northern alignment. On its east and south sides, the street abuts Oakland International Airport, which is chain-link fenced and unscreened for much of the length. A dynamic, linear image is created along the golf courses and northern airport edge with vertical, large-stature, mature street trees.

The business park developments include a spacious, landscaped right-of-way, densely planted with trees. The industrial nature of the airport property abruptly intrudes upon the park-like character created by the business park landscape. On the other hand, the western end of Harbor Bay Parkway runs along the edge of the San Francisco Bay; it terminates at the beginning of Shoreline Park, a public promenade at the water's edge that has magnificent views of the San Francisco skyline. This end is reminiscent of the Shoreline Drive beachfront. In total, the street has three distinct streetscape images, created by the linear, park-like feeling along the golf courses, the industrial zone with no real identity at the southeastern edge, and the open, spacious, park-like character at the business developments and shoreline park.

### **Existing trees**

#### **Doolittle Avenue to Maitland Avenue:**

*Populus nigra* 'Italica' - Lombardy poplar

*Eucalyptus rudis* - swamp gum

*Myoporum laetum* - Myoporum

#### **Maitland Avenue to South Loop Road:**

*Alnus rhombifolia* - white alder

*Pinus pinea* - stone pine

**South Loop Road to End:**

*Phoenix canariensis* - Canary Island date palm

**Planting Recommendations**

Retain existing planting scheme for those species in the tree matrix, but consider substituting *Fagus sylvatica* (European beech) for the existing *Alnus rhombifolia* (white alder).

## HIGH STREET

High Street is a major north/south boulevard that lies on the eastern side of mainland Alameda. It comprises single-family residences built primarily in the 1920s to 1930s, but it also contains buildings dating back as early as 1885. Its streetscape image is fairly cohesive, and the strongest undercurrent is its buildings of similar architectural style. This is coupled effectively with generally uniform street tree plantings. High Street includes a few commercial properties, a school site, and park. South of Encinal, the street plantings are excellent.

### Existing Trees

*Fraxinus velutina* var. *glabra* - Modesto ash

*Fraxinus holotricha* 'Moraine' - Moraine ash

*Fraxinus oxycarpa* 'Raywood' - Raywood ash

### Planting Recommendations

\**Gymnocladus dioica* 'Espresso' - seedless Kentucky coffee tree

*Koelreuteria bipinnata* - Chinese flame tree

*Pistachia chinensis* 'Keith Davey' - Chinese pistache

### Design Recommendations

Conscientious plantings in available vacant planting spaces will improve street canopy consistency north of Encinal. Do not continue planting ash trees, due to the borer threat. Use species such as Chinese flame tree, Chinese pistache, and seedless Kentucky coffee tree instead.

\*Experimental or trial.

**ISLAND DRIVE**

Island Drive is the main arterial and entrance into the southern end of Alameda and Bay Farm Island. The northern end of Island Drive has a strong, park-like character created by its generous width, wide medians, landscaped walkways on both sides, and sweeping views across the Alameda Municipal Golf Courses and clubhouse, built in 1926. From the Otis-Doolittle Drive Bridge, built in 1951, to Mecartney Road, where multi-family residential gives way to commercial development on either side, development occurred during the 1970s and 1980s.

Beyond Mecartney Road, the streetscape character changes significantly to an older, one-story residential neighborhood built from the late 1950s to 1960s with no median, varied street tree plantings, and walls and sidewalks on both sides. Beyond Fir Avenue, the street image changes again, with two-story townhouses built in the 1970s surrounded by common landscape grounds. Although the many street trees are still young, the landscape treatment creates an identifiable residential image.

**Existing Trees****Doolittle to Mecartney Road medians:**

*Pinus radiata* - Monterey pine  
*Alnus rhombifolia* - white alder  
*Pinus pinea* - stone pine  
*Platanus acerifolia* - London plane tree  
*Prunus cerasifera* - purple leaf plum

**Streetscape:**

*Pinus contorta* - lodgepole pine  
*Pinus pinea* - stone pine  
*Prunus cerasifera* - purple leaf plum  
*Populus nigra* 'Italica' - Lombardy poplar

**Mecartney Road to Fir Avenue:**

*Ginkgo biloba* - maidenhair tree

**Fir Avenue to Catalina:**

*Eucalyptus polyanthemos* - silver dollar gum

*Quercus ilex* - holly oak  
*Ginkgo biloba* - maidenhair tree

**Planting Recommendations**

**North of Mecartney Road:**

Retain existing *Populus nigra* 'Italica' (Lombardy poplars) and substitute *Fagus sylvatica* (European beech) for the existing *Alnus rhombifolia* (white alders)

**South of Mecartney Road:**

*Quercus coccinea* - scarlet oak

*Tilia tomentosa* - silver linden

*Corymbia ficifolia* - red-flowering gum.

*Ginkgo biloba* 'Fairmount', 'Saratoga' and possibly other varieties, but not 'Autumn Gold' - maidenhair tree



**LINCOLN AVENUE – TILDEN WAY –  
MARSHALL WAY – PACIFIC AVENUE**

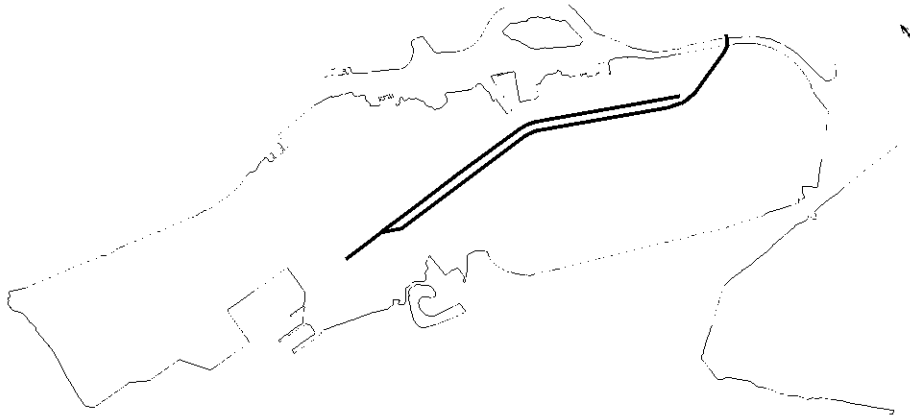

Lincoln Avenue in combination with Pacific Ave (West of 4th Street) Marshall Way (between 4th and 5th Streets) and Tilden Way (East of Park Street) is a major four-lane east/west street through mainland Alameda. It is the widest street in Alameda, with parallel parking along both sides of the street. Lincoln stretches from the Naval Air Station at its western end to the Fruitvale Bridge at its eastern terminus. Its development comprises one- and two-story residences dating mainly from approximately the 1890s through the 1950s. It contains buildings built as early as 1872. There are one-story commercial properties occurring primarily along Lincoln's center and at a few intersections.

Lincoln Avenue has a strong neighborhood identity. The corner markets and stores strongly reinforce Lincoln's character and give it human scale. Some of the corner markets date from the late 1800s to early 1900s. Currently, the street is modestly enhanced by street tree plantings that vary in health, species, and continuity. Beyond Webster and after the curve towards the western end of the island, planting consistency is much better than on the eastern end; the median at Sherman is especially well designed.

Many of the vacant planting spots and some entire planting strips have been covered in asphalt. Lincoln will clearly benefit from not only more consistent plantings but also improved planting conditions. As a major cross street, Lincoln has tremendous potential to become a wonderful street.

**Existing Trees**

*Brachychiton populneus* - bottle tree

*Cinnamomum camphora* - camphor

*Prunus caroliniana* - Carolina cherry laurel

**St. Charles Street to Sherman Street:**

Chinese pistache trees have been planted to replace laurel figs killed by the 1990 frost. The low-branching and initially awkward structure of this species will have

\*Experimental or trial.

to be monitored carefully in order for these trees to function properly in this small commercial district.

**Marshall Way/Pacific Avenue:**

*Cinnamomum camphora* - camphor

*Tristania conferta* - Brisbane box

**Planting Recommendations**

*Tilia tomentosa* - silver linden

*Ulmus* 'Princeton', 'Frontier', \*'Accolade', \*'Commendation', \*'Jefferson', \*'New Harmony', \*'Patriot', \*'Triumph', \*'Washington', and possibly other varieties - various American and hybrid elms

*Metrosideros excelsus* - New Zealand Christmas tree

*Pistacia chinensis* 'Keith Davey' - Chinese pistache

*Quercus coccinea* - scarlet oak

**Design Recommendations**

Plant closely placed ornamental trees. Strong seasonal color would nicely compensate for the absence of a large overhanging canopy.

Lincoln should be considered a priority street. Priority actions should include removing trees that are in decline.

Tilden Way: Currently there are no planter strips. If planned reconstruction of the street is completed then planting recommendations can be implemented.

\*Experimental or trial.

**MAIN STREET**

Housing development along Main Street occurred mostly during the late 1800s to 1920s and in the 1950s. Along the entire west alignment of Main Street is Alameda Naval Air Station land, which is chain-link fenced and which includes storage yards as well as military housing and offices. When the first Master Tree Plan was drafted in 1989, there were no sidewalks, medians, or curbs along the east side. Currently, a new bike and pedestrian path runs along the eastern side, north of Atlantic Avenue. There are extensive plantings, and the landscape appears well established.

On the western side, the naval base is slated for development, so improved street trees will necessarily be a part of that new development. Also, there is a portion of the old Main Street alignment dislocated from the present Main Street by a wide, barren easement. From Atlantic to Pacific Avenue, Main Street changes to four lanes without medians. The housing here dates from approximately 1890 to 1904 and later. The connection of the buildings to the street is weak because the old Main Street alignment is separated from the new Main Street. It would create a more positive image if enhanced by uniform street tree planting and/or streetscape development, such as pedestrian walkways and connections from the old street alignment to the new.

At the northern end of Main Street is the Alameda Ferry Station terminal, built on an open, exposed site on the Inner Harbor. There is also a general industrial zone at the piers. This site is interrupted by Naval Air Station land for several blocks to the south, then it meets private land again at Hollister Circle, where low-cost housing is located. The wide, barren right-of-way zone along the eastern right-of-way would benefit from street tree planting, which would create a positive streetscape image and mitigate the harshness and chaos of the area. Hopefully, all these plantings will coincide with the new development planned for the naval base.

**Existing Trees**

*Prunus caroliniana* - Carolina laurel cherry

*Alnus rhombifolia* - white alder

*Koelreuteria bipinnata* - Chinese flame tree

**Planting Recommendations**

To be deferred and coordinated with Alameda Point development using the Tree Matrix.

**Design Recommendations**

Carefully connect all future developments in the historic naval base with the surrounding street tree plantings. Main Street is currently a serious misnomer, as it actually feels like an end street. Careful streetscape design and mid-block plantings along the naval base could create a beautiful entrance parkway for the development at former navy site.

**MARINA VILLAGE PARKWAY**

This street has well-defined circulation and a strong sense of streetscape image. Street tree landscape plantings and medians were planned as a unit. The northern end of Marina Village Parkway relates to the Marina and estuary, and includes renovated offices that were former World War II Liberty ship construction sites. Marina Village Parkway changes to shopping center and townhouse developments toward the south. The street changes to four lanes without a median, but continues its integrated, consistent streetscape to Constitution Way.

**Existing Trees**

*Acacia baileyana* - Bailey acacia  
*Alnus cordata* - Italian alder  
*Platanus acerifolia* - London plane tree  
*Myoporum laetum* - Myoporum  
*Pinus eldarica* - Afghan pine  
*Populus nigra* 'Italica' - Lombardy poplar

**Planting Recommendations**

*Platanus acerifolia* 'Yarwood' - London plane tree  
*Fagus sylvatica* - European beech.

## MECARTNEY ROAD

Mecartney Road is an important boulevard in Bay Farm Island. West of Island Drive to its terminus at Aughinbaugh Way, Mecartney presents a strong streetscape image, very similar to the northern end of Island Drive and of the same era: 1970s and 1980s multi-family development. It has wide landscaped medians and four lanes of traffic. From Island Drive east, Mecartney is a minor residential collector route through single-story residential development dating from approximately 1909 to the 1920s, 1930s, 1950s, and 1960s. There is little streetscape image because of few and small-scale street trees, no medians, and little attention paid to the pedestrian experience along its length. At Holly Street, the residences change to multi-family housing and the street image continues to lack identity.

### Existing Trees

*Eucalyptus rudis* - swamp gum

*Ceratonia siliqua* - carob

*Cinnamomum camphora* - camphor

*Fraxinus species* - ash

### Island Drive to Aughinbaugh Way:

*Platanus acerifolia* - London plane tree

*Acacia baileyana* - Bailey acacia

*Prunus cerasifera* - purple leaf plum

*Pinus pinea* - stone pine

*Pinus radiata* - Monterey pine

*Populus nigra* 'Italica' - Lombardy poplar

### Planting Recommendations

\**Gymnocladus dioica* 'Espresso' - seedless Kentucky coffee tree.

*Platanus acerifolia* 'Columbia' and 'Yarwood' - London plane tree

*Corymbia ficifolia* - red-flowering gum

### Design Recommendations

Do not continue planting ash trees, due to the borer threat. Use ash-like species instead, such as seedless Kentucky coffee tree.

**OTIS DRIVE**

Otis Drive is an important east/west collector route that runs along the south side of mainland Alameda. Its eastern end is characterized by two lanes with small-stature mature street trees, which provide a unique identity but seem too small for the scale of the street. More trees should be planted where vacancies allow, speeding the process of strengthening the streetscape. There is a strong neighborhood character, with single-family development dating from the 1930s and 1940s on the east side, and from the 1960s to the west. Here, the lagoons lie south of, and are not visible from, Otis.

At Grand, the street tree plantings increase in number and consistency. At Park Street, the roadway changes to four lanes, surrounded by dense, multi-family housing and commercial one-story buildings. Just beyond Park, the lagoons switch to the north side of Otis and become the primary focus of the multi-family housing. The current lagoon landscaping along the northern side of Otis is excellent, and should be maintained with pride by the City. Also at Park Street, there is the relatively new mall development, Alameda Towne Center, with many small street trees that should, with careful maintenance, mature into a strong street tree canopy along the mall. The residences along here were built mostly in the 1960s. The western end of Otis Drive has a more definite streetscape identity; though the street trees are of varying stature and age, a pattern continues until the terminus of Otis at Westline Drive, across from the Robert Crown Memorial State Beach entrance.

**Existing Trees****Bay Farm Island Bridge to Park Street:**

*Myoporum laetum* - Myoporum

*Crataegus laevigata* - English hawthorn

*Ligustrum lucidum* – glossy privet

**Park Street to Westline Drive:**

*Tristania conferta* - Brisbane box

*Eucalyptus rudis* - swamp gum

*Pyrus Calleryana* - flowering pear

\*Experimental or trial.

**Planting Recommendations**

*Corymbia ficifolia* - red-flowering gum

*Metrosideros excelsus* - New Zealand Christmas tree

*Pyrus calleryana* 'Aristocrat' - flowering pear

*Tilia tomentosa* - silver linden. For use where bay mud soils are not present

**Design Recommendations**

Significant work has been completed along Otis Drive. Planting vacancies should be filled in to maximize the benefits of the already completed work.



## PARK STREET

Park Street is one of the major commercial streets in Alameda, and it has a very strong sense of identity. It successfully deals with circulation and the combination of pedestrian and vehicular ways. The architecture dominates the streetscape, ranging from vintage 1880s to 1909 Victorian and Edwardian to 1920s and newer structures. The street trees from Central to Times Way were replaced with Ginkgo and Crape Myrtle as part of the phase 1 streetscape project. Phase 2 is scheduled to begin in 2009 and will modify the plantings between Times Way and Lincoln as well as between Central and Encinal.

From Encinal southward, the commercial buildings are primarily from the 1880s to 1920s, and they match the residential character to which the street transitions at its southern end. Here, there are medium- to large-stature trees and a change to two lanes from four; these changes strengthen the residential character of the streetscape.

There are also many new trees between Encinal and Otis that have tremendous street canopy potential. Beyond Otis Drive, there is a single-story shopping center development that continues to Shoreline Drive without street trees or residential buildings. In 1989, the end of Park Street was completely divided from the older portion, as there was no consistency between the old and the new parts of the street. As a result of tree plantings by the City, there is currently a much better connection between the old and new parts of Park Street.

### **Existing trees**

The frost in the winter of 1990 damaged and killed nearly all the laurel figs in the business district of Park Street; some of them have recently been replaced with swamp myrtle, which proved unsatisfactory due to litter and difficulty achieving 15' vertical clearance to maintain visibility of store signage. In 2005-2006, phase 1 of the streetscape project installed Ginkgos and Crape Myrtle. There are still several cherry laurels and glossy privets throughout the business district. The large parkways between Otis Drive and San Jose Avenue are perfect sites for large-stature trees.

**Planting Recommendations**

**North of Clinton Avenue (in commercial district):** *Ginkgo biloba* 'Fairmount' - maidenhair tree

*Lagerstroemia indica* x *L. fauriei* Crape Myrtle 'Tuscarora' and possibly other varieties

**South of Clinton Avenue:**

*Ginkgo biloba* 'Fairmount' or 'Saratoga' - maidenhair tree. Do not plant 'Fairmount' under high voltage lines.

*Quercus coccinea* - scarlet oak

\**Quercus falcata* - southern red oak. Do not plant under high voltage lines.

**Design Recommendations**

Continue to maintain younger trees, and plant new trees in existing vacant locations.

Park Street should be considered a priority street. Priority actions include removing trees that are in decline and planting new ones.

Phase 3 of the streetscape project will select trees from the tree matrix for the remaining portion of the commercial development, north of Lincoln.

**ROBERT DAVEY JR. DRIVE (formerly BRIDGEWAY ROAD)**

Robert Davey Jr. Drive is a residential collector road between Island Drive and the developments at the northwestern end of Bay Farm Island. It was planned in conjunction with other Bay Farm Island development initiated in the 1970s and has a similar character to Island Drive and Mecartney Road, though it is smaller in scale.

Although rear residential lots here back onto the street, there are attractive wood fences and landscaped pathways that mitigate the separation. These fences meander along the length of Robert Davey Jr. Drive, echoing the curved nature of the street itself and presenting an inviting, park-like experience for either vehicular or pedestrian use.

**Existing trees**

Along sidewalks:

*Platanus acerifolia* - London plane tree

In medians:

*Alnus rhombifolia* - white alder

*Acacia baileyana* - Bailey acacia

*Prunus cerasifera* - purple leaf plum

*Pinus pinea* - stone pine

*Pinus radiata* - Monterey pine

**Planting Recommendations**

*Platanus acerifolia* - London plane tree, 'Yarwood' or 'Columbia'

*Fagus sylvatica* - European beech. Use to replace the existing *Alnus rhombifolia*

## SANTA CLARA AVENUE

Santa Clara Avenue is a major east/west boulevard through mainland Alameda. At its extreme western end, it sets a good example of strong streetscape character for a smaller, residential collector street. Its identity is created and reinforced by homes of similar type and character, and by a streetscape that supports the residential intent of the area. There are two lanes, sidewalks on both sides, and uniform, large-stature street tree plantings that enhance the scale of the residences. The homes are single-story and were built from approximately 1880 to 1930. Additionally, some date from prior to 1872, when the City of Alameda started keeping official records.

Progressing east along Santa Clara Avenue, the mature street trees have begun to die out and have been removed in places. Further on, new medium-stature trees replace the trees that were removed. Because of varying tree age and species, the uniform image of the street starts to break down and it loses some of its identity.

At the Webster Street intersection, the housing changes to two-story multi-family mingled with one-story single-family residential. Beyond Webster at Eighth Street, we begin to see fewer street trees of various species and age. Further east past Stanton, there are areas of multi-family housing, schools, and churches, though most development remains single-family residential. Overall, Santa Clara Avenue has a strongly residential character, which could be enhanced by a more uniform street tree planting along its length. Since 1989, the character of Santa Clara has not changed significantly. Santa Clara still has tremendous potential, since it has a natural scale ideal for a strong streetscape and canopy coverage.

### Existing Trees

*Cinnamomum camphora* - camphor

*Ceratonia siliqua* - carob

*Prunus caroliniana* - Carolina cherry laurel

*Quercus agrifolia* - coast live oak

*Tristania conferta* - Brisbane box

### Planting Recommendations

Keep the all-evergreen look established by the surviving camphor trees by planting the following:

*Tristania conferta* - Brisbane box

*Corymbia ficifolia* - red-flowering gum

*Metrosideros excelsus* - New Zealand Christmas tree

*Quercus virginiana* - southern live oak

### **Design Recommendations**

Santa Clara should be another priority street, because of the street's wonderful natural scale and tremendous potential. Priority actions should include removing trees that are in decline and planting new ones.

## SHORELINE DRIVE

The nature of Shoreline Drive is very different from other streets as it affords sweeping views of the San Francisco Bay and the San Francisco skyline. This street is also unique in that it serves public beaches along its length. It is protected from some buffeting at its southern end by the Bay Farm Island land mass.

The land that fronts Shoreline Drive was created by landfill in the mid-1950s to the 1960s. It is characterized by multi-family residential buildings built in the 1950s on the north end, which range from two- to four-story and which all face the bay. The residential character is interrupted at its eastern end for several blocks by one- and two-story commercial developments. Its streetscape image is dominated by its wide-open feeling and bay view, which help to mitigate the height of the buildings along its north side, versus the horizontal character of the beach on the south.

### Existing trees

*Pittosporum undulatum* - mock orange

*Myoporum laetum* - Myoporum

*Metrosideros excelsus* - New Zealand Christmas tree

### Planting Recommendations

In order to protect views from the adjacent apartments The City should only plant *Washingtonia robusta* (Mexican fan palm). If *W. robusta* are planted, they should be planted all at once to ensure uniform height. Some of the existing *Metrosideros excelsus* may have become too large and dense for view protection. If there is a desire to maintain them, some of them may need to be removed so that there is more separation between the trees to maintain view corridors. Minimum spacing may range from a minimum of 40' and maximum of 60' to maintain 20' separation between canopies. A 30' maximum tree spacing is generally too close to preserve views, especially for spreading species like *M. Excelsus* which would require up to 60' of tree spacing. So it may be necessary to space so that a 30 degree view corridor is provided. The removals could be phased over time as the trees mature. A detailed discussion of view corridors is in the following "Design" section of the Master Street Tree Plan. Italian Cypress is recommended as a possible alternative to *M. Excelsus* but spacing would have to be modified to a 20' rule.

**Design Recommendations**

Due to the unique conditions along Shoreline Drive, the street deserves a carefully considered streetscape plan. Both sides of the street should be oriented towards the bay, trees that severely obstruct residents' views should be removed where appropriate. An ideal Shoreline planting palette would connect the residential side of the street with the beach side of the street using beach grasses and native plantings.

Shoreline Drive should be considered a priority street. Priority actions should include removing trees that are in decline.

**Private Views and Public Trees**

Many homes are located along Shoreline Drive. These homes often would have dramatic views of the San Francisco skyline and the San Francisco Bay, were it not for trees in the public right of way. The City has never adopted an official policy that negotiates conflicts between public street trees and private views. Currently, street trees can be pruned for private views but cannot be topped or removed solely for that purpose. To improve coastal view sheds, the following guidelines are suggested:

- Existing healthy trees shall not be removed.
- Replacement tree plantings must be from the Shoreline Drive planting palette which include monoculture of *W. robusta* or a *sempervirens* 'stricta' or a mix of *W. robusta* and *M. excelsus*.
- No more than 10% of the trees will be removed in any year.
- Responsibility rests with the property owner to petition the City to change tree spacing and modify the established view shed.
- Removal of existing street trees to increase view shed should follow the Min 20 Feet Rule for *W. Robusta* and Italian Cypress (see Figures 1.1A and B)

Figure 1.1 A / Before removal of street trees to provide coastal views.

Figure 1.1 B / Removal of street trees using the Min 20 Feet Rule allows for coastal views while maintaining same canopy cover.



**WEBSTER STREET**

Webster Street is one of the major commercial corridors in Alameda and has a strong sense of identity. This is the main entrance to the city, and it begins in an area of stores and small businesses (refer to the “City Entry Gateways” section for further discussion). Webster Street, which is entirely a business district, successfully manages circulation and the combination of pedestrian and vehicular ways. The architecture dominates the streetscape, with structures mostly built in the 1940s and later, along with some older buildings. Webster has a completely new streetscape with an extensive new planting program that includes many new trees, plantings, light fixtures, and bump-outs.

**Existing Trees**

*Pyrus calleryana* ‘Aristocrat’ - flowering pear

*Lagerstroemia indica*

**Planting Recommendations**

*Pyrus calleryana* ‘Aristocrat’ - flowering pear

*Lagerstroemia indica* x *L. fauriei* ‘Tuscarora’ - crape myrtle. Use as an accent tree.

## **WESTLINE - EIGHTH STREET - CONSTITUTION WAY**

This major boulevard travels through three distinct eras in Alameda's history. Eighth Street represents the oldest portion, Westline Drive was built in the 1950s, and Constitution Way development has largely been completed in the last five years. Eighth Street has a very residential character and an attractive streetscape, with one lane of traffic each way. Within the Burbank-Portola Heritage Area, it is comprised mostly of Craftsman-style bungalows that date from 1912 to 1914. From Central Avenue north, there are also two-story apartments from the 1920s to 1930s, convincingly made to look like single homes, as well as a school site. There is a mix of evergreen and deciduous street trees, most of which are mature, medium- to large-scale trees.

Progressing towards Constitution, the streetscape development is much newer. The street changes to four lanes, and because houses face on side streets, ivy-covered privacy walls jog alongside the street. At its intersection with Shoreline Drive, Westline Drive is characterized by beach and park land with large park trees on the west side, in contrast to high-density housing to the east. This area was constructed during the 1950s to 1960s.

Portola Avenue is the location of the old seawall and what was once the southernmost edge of Alameda, prior to the formation of new land with fill soil south of the seawall in 1956. In 1964, Eighth Street was extended to what is now Shoreline Drive. This area still has a strong sense of identity created by the bungalow architecture, the uniform, mature palm tree plantings, and the adjacent parks. North of Buena Vista Avenue, Constitution Way, which previously had a disoriented feeling because of the varied land uses, has now developed a stronger pedestrian connection as the result of new plantings. At Marina Village Parkway, this identity gives way to a well-planned commercial development on the east. Eighth Street at Haight Street shows some wonderful street tree plantings.

### **Existing Trees**

#### **Eighth Street:**

*Washingtonia robusta* - Mexican fan palm

*Robinia pseudoacacia* - black locust

*Fraxinus holotricha* 'Moraine' - Moraine ash 'Tilia'

**Constitution Way:**

*Magnolia grandiflora* - southern magnolia - sides

*Alnus rhombifolia* - white alder - median

*Prunus x blireiana* - flowering plum - median

*Jacaranda mimosifolia* - Jacaranda - median

*Pistachia Chinensis* - median

*Platanus acerifolia* - sides and median

*Tristania conferta* - sides

**Westline Drive:**

*Eucalyptus rudis* - swamp gum

*Pittosporum undulatum* - victoria bay

**Planting Recommendations****Constitution Way north of Lincoln:**

*Tristania conferta* - Brisbane box

*Platanus acerifolia* 'Columbia' and 'Yarwood' - London plane tree

*Magnolia grandiflora* 'Russett' - southern magnolia

**Eighth Street north of Central:**

*Tristania conferta* - Brisbane box

**Eighth Street between Central and Portola:**

*Washingtonia robusta* - Mexican fan palm

**West Line Drive:**

*Corymbia ficifolia* - red-flowering gum

*Tristania conferta* - Brisbane box

*Platanus acerifolia* 'Columbia' and 'Yarwood'

- London plane tree

## 1.2 / NEIGHBORHOODS OF ALAMEDA

The following section contains summaries of the existing tree populations within the 22 neighborhoods of Alameda that are identified by the US Census Bureau. Major streets that are found within neighborhoods are treated separately in the previous section of this plan. The discussion also contains recommendations for replacement tree species to be used in a variety of environments due to lack of availability or problem with species identified in neighborhood palette. Changes to the neighborhood tree selection lists must be approved by the Public Works Director and must only include tree species drawn from the Tree Matrix at the end of this MSTP. Such changes must be approved by the Planning Board.

### NEIGHBORHOOD TREE RECOMMENDATION PARAMETERS

The neighborhood recommendations presented in this section are based on the following parameters:

1. The tree selections are drawn from the non-experimental trees shown on the Tree Matrix and reflect the matrix information on such issues as minimum planting area size and seaside tolerance. Note, however, that the City of Alameda Tree Matrix's experimental trees can also be included as neighborhood trees as described below in "Experimental Trees."
2. The recommended trees from the 1989 Master Tree Plan neighborhood lists are retained, except where: (a) they were deleted from the Tree Matrix, or (b) they were deleted from the 1989 neighborhood list because of the considerations listed below.
3. The total number of tree species recommended for each neighborhood ranges from two to ten, based primarily on the number of vacant planting sites, but also on achieving a balance between retaining existing desirable trees on the lists and offering residents a choice of trees as discussed in Item 4 below.
4. Each neighborhood list is designed for a greater planting complexity by recommending at least one each of the following: a large evergreen tree, a large deciduous tree, a small tree, a tree with spring flowers, and a tree with good fall color.
5. *Platanus acerifolia* is not shown on the neighborhood lists because it is overplanted in Alameda.
6. *Ginkgo biloba* is deleted from the 1989 planting lists for East Central and Northside East because it is also overplanted in the city. It also has not been added to any new neighborhoods.
7. *Pyrus calleryana* is not included in the neighborhood lists (except for commercial areas) because of continued maintenance concerns.
8. *Magnolia grandiflora* should only be used on a limited basis where planting areas are large enough. The neighborhood recommendations, therefore, assume a planting area size for *M. grandiflora* in five-foot wide planter strips. *Magnolia*

*grandiflora* planting recommendations have been retained in the three neighborhoods where it is already listed in the 1989 plan. All three neighborhoods have planting areas up to six feet wide. Additionally, *Magnolia grandiflora* is added to the Bayview/Shoreline neighborhood, which has a high number of large planting areas up to seven feet wide.

9. There was an effort to make significant use of all non-experimental trees in the approved Tree Matrix, while avoiding overuse of any one tree. Therefore, except for *Platanus acerifolia* and *Pyrus calleryana* (which have been overplanted), each non-experimental tree is used for at least two neighborhoods and up to a maximum of seven neighborhoods.

### **EXPERIMENTAL TREES**

In addition to the species and varieties listed for each neighborhood, the species and varieties identified as “experimental” on the citywide Tree Species Matrix can be used in any neighborhood if they are provided the minimum planting area size shown in the matrix, and are well suited to the planting site’s environmental conditions (drainage conditions, soil, seaside exposure, etc.). Although designated as experimental, all of these trees are believed likely to do well in Alameda as street trees, and their use is strongly encouraged. The objective is to establish approximately 10 street tree examples of each experimental species or variety in the city for ongoing monitoring and evaluation.

In some cases, the evaluation period may only last several years, but in other cases, such as where the tree’s hardscape damage potential is not well known, a longer evaluation will be required. If the tree proves satisfactory after completion of the evaluation period, it is recommended that it be retained in the matrix on a non-experimental basis, added to the neighborhood tree lists, and possibly added to the major street designations. If the tree proves unsatisfactory, it will be removed from the matrix and not used further in Alameda.

### **SPECIAL NEIGHBORHOOD STREETS**

Within some Alameda neighborhoods there are streets with an extraordinary developed tree character or pattern. Planting efforts along these neighborhood streets should strengthen and maintain this character. The following page shows the list of these special neighborhood streets and their existing species and recommended species.

STREET	LOCATION	EXISTING SPECIES
Alameda Ave.	1500 - 2100 block	Red Oak Species ( <i>Quercus</i> spp.)
Bay St.	1100 - 1200 blocks	English Elm ( <i>Ulmus procera</i> )
Burbank St.	1300 block	Mexican Fan Palm ( <i>Washingtonia robusta</i> )
Eighth St.	1300 - block	California Fan Palm ( <i>Washingtonia filifera</i> ), Mexican Fan Palm ( <i>Washingtonia robusta</i> )
Portola Ave.	800 block	Mexican Fan Palm ( <i>Washingtonia robusta</i> )
Union St.	1400 block	Silver Linden ( <i>Tilia tomentosa</i> )
Stanton St.	1500 block	Red Oak Species ( <i>Quercus</i> spp.)
Johnson Ave.	2900 block	European Hornbeam ( <i>Carpinus betulus</i> )
Mozart St. and Verdi St.	Entire length	London Planetree ( <i>Platanus acerifolia</i> )
Bay St.	Lincoln Ave. - Eagle Ave.	Aristocrat Pear ( <i>Pyrus calleryana</i> 'Aristocrat')
Chapin St.	Lincoln Ave. - Eagle Ave.	Sweetgum ( <i>Liquidambar styraciflua</i> )
Sherman St.	Lincoln Ave. - Eagle Ave.	Brisbane Box ( <i>Lophostemon confertus</i> )
Pacific Ave.	Bay St. - Wood St.	Aristocrat Pear ( <i>Pyrus calleryana</i> 'Aristocrat')
Park Ave.	Entire length	London Planetree ( <i>Platanus acerifolia</i> )
Grove St. and Fountain St.	Encinal Ave. - Jackson St.	Sweetgum ( <i>Liquidambar styraciflua</i> )
Sherman St.	San Antonio Ave. - Encinal Ave.	Sweetgum ( <i>Liquidambar styraciflua</i> )
Morton and St. Charles St.	San Antonio Ave. - Encinal Ave.	Black Locust ( <i>Robinia pseudoacacia</i> )

## RECOMMENDED SPECIES

---

Shumard Oak (*Quercus shumardii*), Scarlet Oak (*Quercus coccinea*)

---

Silver Linden (*Tilia tomentosa*), American Elm cultivars (*Ulmus americana*), Hybrid Elm (*Ulmus* spp.)

---

Mexican Fan Palm (*Washingtonia robusta*)

---

Mexican Fan Palm (*Washingtonia robusta*)

---

Mexican Fan Palm (*Washingtonia robusta*)

---

Silver Linden (*Tilia tomentosa* 'Sterling' or 'Green Mountain')

---

Shumard Oak (*Quercus shumardii*), Scarlet Oak (*Quercus coccinea*)

---

European Hornbeam cultivars (*Carpinus betulus* 'Frans Fontaine' and *C. betulus* 'Fastigata')

---

American Hornbeam (*Carpinus caroliniana*)

---

London Planetree cultivars (*Platanus acerifolia* 'Bloodgood', *P. acerifolia* 'Columbia', and *P. acerifolia* 'Yarwood')

---

Continue Pyrus Calleryana 'Aristocrat' or use Acer rubrum 'October Glory'

---

October Glory Maple (*Acer rubrum* 'October Glory'), Brandywine Maple (*Acer rubrum* 'Brandywine'), Scarlet Oak (*Quercus coccinea*)

---

Brisbane Box (*Lophostemon confertus*)

---

Silver Linden cultivars (*Tilia tomentosa* 'Green Mountain' and *T. tomentosa* 'Sterling') Pyrus Calleryana 'Aristocrat'

---

London Planetree cultivars (*Platanus acerifolia*, *P. acerifolia* 'Columbia', and 'Yarwood')

---

*Acer rubrum* 'October Glory', *Quercus coccinea*

---

*Acer rubrum* 'October Glory', *Quercus coccinea*

---

Kentucky Coffee Tree (*Gymnocladus dioecia* 'Espresso') *Kochreuteria Bipinata*

---

## **BALLENA BAY**

Street trees in this neighborhood are limited to Ballena Boulevard, Tideway, and Cola Ballena. This neighborhood was not surveyed in the 2008 tree inventory.

### **Existing Trees:**

*Alnus cordata*

*Eucalyptus rudis*

*Metrosideros excelsus*

### **Planting Recommendations:**

*Carpinus betulus* 'Fastigiata' - fastigate hornbeam

*Metrosideros excelsus* - New Zealand Christmas tree



**BAY FARM ISLAND**

**Total # trees surveyed:** 3720

**Vacant Sites:** 455

**Range of Planting Strip Widths:** 2-7 feet (there are many trees in the wide medians on Island Drive and Mecartney Road, but only a few available spaces for planting in these locations).

**Existing Trees:**

*Alnus rhombifolia*

*Fraxinus angustifolia*

*Platanus acerifolia*

*Prunus cerasifera*

*Pyrus calleryana*

*Tristania conferta*

The absence of overhead utilities and the relatively large planting strips found here provide an opportunity for planting large-stature trees. Maintenance in this area is currently being shared by the homeowners' association and the City. In many of the new developments, trees are being planted at a spacing pattern far too dense for the eventual mature dimensions of these trees. Future thinning out of these trees may be necessary in order to maintain the overall health of this sub-population.

**Improved planting scheme selections:**

*Acer campestre* - hedge maple

*Tristania laurina* - swamp myrtle

*Metrosideros excelsus* - New Zealand Christmas tree *Aesculus hippocastanum*

'Baumannii' - Baumann's horsechestnut

*Corymbia ficifolia* - red-flowering gum

*Jacaranda mimosifolia* - Jacaranda

*Quercus coccinea* - scarlet oak

*Quercus palustris* - pin oak

*Quercus suber* - cork oak

## **BAY MOUND**

**Total # trees surveyed:** 1227

**Vacant Sites:** 429

**Range of Planting Strip Widths:** 2-7 feet

### **Existing Trees:**

*Cinnamomum camphora*

*Crataegus laevigata*

*Fraxinus oxycarpa*

*Fraxinus uhdei*

*Fraxinus velutina*

*Geijera parviflora*

*Ginkgo biloba*

*Metrosideros excelsus*

*Myoporum laetum*

*Platanus acerifolia*

*Prunus caroliniana*

*Pyrus calleryana*

*Sapium sebiferum*

Five species comprise the majority of the tree population in this neighborhood. These trees are distributed fairly evenly between Camphor, Myoporum, Carolina Cherry, and Carob. Unfortunately, many of these species are notorious for uplifting sidewalks; they are also the species which will mature when they reach heights of 30 feet or less. The Camphor are mostly 12-18" diameter at breast height (DBH). Overall, the majority of the trees in the neighborhood are 3-6" DBH, indicating a young population. Because there are vacant planting sites available, there are many opportunities to change species diversity. New tree species could be planted, establishing a significant tree canopy in anticipation of removing the more destructive species such as Camphor, - Carob, and Indian Laurel Fig.

**Planting Recommendations:**

*Acer buergeranum* - trident maple

*Acer campestre* - hedge maple

*Aesculus carnea* - red horsechestnut

*Corymbia ficifolia* - red-flowering gum

*Metrosideros excelsus* - New Zealand Christmas tree

*Acer saccharum* 'Commemoration' - sugar maple *Carpinus betulus* 'Fastigiata'  
and 'Frans 'Fontaine' - hornbeam *Pistacia chinensis*

*Jacaranda mimosifolia* - Jacaranda

*Quercus palustris* - pin oak

*Ulmus americana* 'Princeton' - elm

## **BAY VIEW**

**Total # trees surveyed:** 59

**Vacant Sites:** 24

**Range of Planting Strip Widths:** 3-7 feet

**Existing Trees:**

*Myoporum laetum*

The public tree population in the Bayview area is limited due to lack of public easement.

**Planting Recommendations:**

*Acer buergeranum* - trident maple

*Acer campestre* - hedge maple

*Aesculus carnea* - red horsechestnut

*Corymbia ficifolia* - red-flowering gum

*Metrosideros excelsus* - New Zealand Christmas tree

*Acer saccharum* 'Commemoration' - sugar maple *Carpinus betulus* 'Fastigiata'  
and 'Frans 'Fontaine' - hornbeam *Pistacia chinensis*

*Jacaranda mimosifolia* - Jacaranda

*Quercus palustris* - pin oak

*Ulmus americana* 'Princeton' - elm

**CENTRAL****Total # trees surveyed:** 384**Vacant Sites:** 118**Range of Planting Strip Widths:** 2-6 feet**Existing Trees:***Brachychiton populneus**Cinnamomum camphora**Liquidambar styraciflua**Platanus acerifolia**Pyrus calleryana*

Excellent, deep soils and many mature trees typify this neighborhood. Many of the older trees are species that cause considerable concrete damage. Most trees are in the 6-12" and 12-18" DBH classes. Seventy percent of the planting sites are 3.5 feet wide, which is a fairly large space compared to the common planting sizes in other parts of the city. The main east/west streets are discussed in the "Major Streets" section of this report. The recommendations made here are meant for the comparatively narrow north/south streets.

**Planting Recommendations:***Acer buergeranum* - trident maple*Acer campestre* - hedge maple*Aesculus carnea* - red horsechestnut*Ginkgo biloba* 'Saratoga' - Saratoga maidenhair tree*Koelreuteria bipinnata* - Chinese flame tree*Podocarpus gracilior* - fern pine*Tilia tomentosa* 'Green Mountain' & 'Sterling' - silver linden

## CENTRAL EAST

**Total # trees surveyed:** 195

**Vacant Sites:** 48

**Range of Planting Strip Widths:** 2-6 feet

**Existing Trees:**

*Ceratonia siliqua*

*Ginkgo biloba*

*Platanus acerifolia*

The major streets of this neighborhood are discussed in the "Major Streets" section. Sections of Oak, Willow, and Walnut Streets in this neighborhood do not have adequate growing space for street trees. New tree wells at least three feet wide should be installed along Oak, Willow, and Walnut Streets to improve planting options.

**Planting Recommendations:**

*Tristania conferta* - Brisbane box

*Acer nigrum* - black maple

*Acer buergeranum* - trident maple

*Aesculus carnea* - red horsechestnut

*Carpinus betulus* 'Frans Fontaine' - hornbeam

*Nyssa sylvatica* - black tupelo

*Tilia tomentosa* 'Green Mountain' and 'Sterling' - silver linden

**EAST CENTRAL****Total # trees surveyed:** 329**Vacant Sites:** 55**Range of Planting Strip Widths:** 2-6 feet**Existing Trees:***Fraxinus velutina**Ginkgo biloba**Ligustrum lucidum**Platanus acerifolia*

London planes account for the majority of the neighborhood trees. The plane trees are fairly large, with the majority of them in the 18-24" and 24-30" DBH class. The inherently poor strength and branching structure of the Modesto ash, combined with the tendency of its roots to uplift the sidewalk, targets this species for removal and replacement with more site-appropriate trees. Recommended species for planting are primarily for streets running north to south, as most of the east to west major streets are treated under the "Major Streets of Alameda" discussion.

**Planting Recommendations:****Commercial areas:***Carpinus betulus* 'Frans Fontaine' - hornbeam*Acer nigrum* 'Greencolumn' - black maple**Residential areas:***Metrosideros excelsus* - New Zealand Christmas tree*Jacaranda mimosifolia* - Jacaranda*Pistacia chinensis* 'Keith Davey' - Chinese pistache*Quercus suber* - cork oak*Ulmus* 'Frontier' - elm

## **EAST END**

**Total # trees surveyed:** 532

**Vacant Sites:** 80

**Range of Planting Strip Widths:** 2-5 feet

### **Existing Trees:**

*Brachychiton populneus*

*Ginkgo biloba*

*Liquidambar styraciflua*

*Platanus acerifolia*

*Prunus caroliniana*

*Pyrus calleryana*

The area is dominated by Ginkgo, plane tree, and Liquidambar species. The majority of the planting sites are 3 to 3.5 feet wide. The shallow rooting habits of Liquidambar can cause extensive sidewalk damage as they mature in size. The Liquidambar here are mature and are showing signs of decline.

### **Planting Recommendations:**

*Metrosideros excelsus* - New Zealand Christmas tree

*Acer saccharum* 'Commemoration' - sugar maple

*Pistacia chinensis* 'Keith Davey' - Chinese pistache

*Tristania laurina* - swamp myrtle

*Lagerstromia* x 'Natchez' and 'Tuscarora' - crape myrtle

*Quercus coccininea*

*Acer rubrum* 'October glory' and Brandy wine



**FERN SIDE****Total # trees surveyed:** 501**Vacant Sites:** 80**Range of Planting Strip Widths:** 2-6 feet**Existing Trees:***Ginkgo biloba**Liquidambar styraciflua*

Approximately half of this neighborhood's trees were surveyed in the 2008 tree inventory. This neighborhood is one of the most densely tree-populated areas of Alameda. In 1989, there were 868 trees with 59% being Ginkgos. The majority of these trees were newly planted in 1989; over 60% of the *Ginkgo* trees are currently less than 6" in diameter. All of the readily available cultivars of the species are seen here, such as fine specimens of 'Autumn Gold' at 3001 and 3009 Marina Drive. Two fine examples of 'Fairmount' may be seen at 2014 Harvard Avenue.

**Planting Recommendations:***Acer x freemanii* 'Autumn Blaze' - Freeman maple*Acer nigrum* 'Green Column' - black maple*Acer rubrum* 'October Glory' and 'Brandywine' - red maple*Tristania conferta* - Brisbane box*Carpinus betulus* 'Fastigata' and 'Frans Fontaine' - hornbeam

Platnus - for planter strip more than 5'

Silver Linden

## **GOLD COAST**

**Total # trees surveyed:** 1095

**Vacant Sites:** 232

**Range of Planting Strip Widths:** 2-6 feet

### **Existing Trees:**

*Ginkgo biloba*

*Liquidambar styraciflua*

*Platanus acerifolia*

*Prunus caroliniana*

*Pyrus calleryana*

*Robinia pseudoacacia*

*Ulmus procera*

*Washingtonia robusta*

This neighborhood contains trees that have some of the largest average DBH measurements in the city. The trees are fairly evenly distributed, but the most frequent species is black locust. The next most frequent species are, in descending order: English elm, Mexican fan palm, Liquidambar, and London plane. Many of the Mexican fan palms are found along Burbank Street. The majority of these top five species are larger than 12" DBH, due in part to the area's exceptionally good soils. The larger sized trees, while very attractive and essential to the ambience of the neighborhood, also cause quite a bit of pavement damage. This neighborhood can continue to add to its already dense tree cover since a total of 232 new planting sites have been identified.

### **Planting Recommendations:**

*Ginkgo biloba* 'Saratoga' - Saratoga maidenhair tree

*Magnolia grandiflora* 'Russet' - southern magnolia

*Magnolia grandiflora* 'St. Mary' - southern magnolia

*Prunus yedoensis* - Yoshino cherry

*Quercus palustris* - pin oak

*Quercus shumardii* - Shumard oak

*Tilia tomentosa* 'Green Mountain' or 'Sterling' - silver linden

*Acer rubrum* 'October Glory' and 'Brandywine' - red maple

*Ulmus* 'Frontier' - hybrid elm

**JACKSON PARK****Total # trees surveyed:** 170**Vacant Sites:** 107**Range of Planting Strip Widths:** 3-7 feet**Existing Trees:***Fraxinus velutina**Platanus acerifolia*

This area is an eclectic mix of architectural styles ranging from two-and-one-half-story refurbished Victorians to large, modern buildings. A significant proportion of the planting strips have been paved over in this area. The London plane trees surrounding Jackson Park, although technically park trees, function as street trees and thus were included in the inventory. The trees that surround this park should remain London plane trees, with the proviso that the existing *Platanus acerifolia* trees be replaced with a disease-resistant cultivar, *Platanus acerifolia* 'Yarwood', or 'Columbia'.

**Planting Recommendations:***Acer x freemanii* 'Autumn Blaze' - Freeman maple*Acer buergeranum* - Trident maple*Acer campestre* - hedge maple*Acer nigrum* 'Green Column' - black maple*Carpinus betulus* 'Fastigiata' - fastigate hornbeam*Koelreuteria bipinnata* - Chinese flame tree*Jacaranda mimosifolia* - Jacaranda*Podocarpus gracilior* - fern pine

## LAGUNARIA

**Total # trees surveyed:** 288

**Vacant Sites:** 83

**Range of Planting Strip Widths:** 2-5 feet

### **Existing Trees:**

*Alnus cordata*

*Ginkgo biloba*

*Platanus acerifolia*

*Pyrus calleryana*

*Tristania conferta*

The short cul-de-sacs north of Otis Drive are without the necessary easement for public street trees. Otis Drive is treated in the "Major Streets" section of this report. The portion of Lagunaria that contains trees is located in a small area south of Otis. The area is notable in that the majority of planting sites are 4.5 feet wide, which is quite a large space compared to those in other neighborhoods. Additionally, none of the planting sites here are obstructed by utility or other service wires. Similar to the Southshore neighborhood, the harshness of bay fill soils, a perched water table, and constant strong winds test the survival of any selected tree species.

### **Planting Recommendations:**

*Corymbia ficifolia* - red-flowering gum

*Podocarpus gracilior* - fern pine

*Quercus coccinea* - scarlet oak

*Quercus palustris* - pin oak

**NORTHSIDE EAST****Total # trees surveyed:** 450**Vacant Sites:** 250**Range of Planting Strip Widths:** 2-5 feet**Existing Trees:***Brachychiton populneus**Liriodendron tulipifera**Pittosporum undulatum**Platanus acerifolia**Pyrus calleryana*

There are 450 trees in this neighborhood with an additional 250 available vacant sites. The soil quality in much of this area is exceptionally good, thus taller-growing species may be selected for these sites. Three of the four major east/west streets are dealt with in the "Major Streets of Alameda" section.

**Planting Recommendations:***Tilia tomentosa* 'Green Mountain' & 'Sterling' - silver linden*Acer rubrum* 'October Glory' & 'Brandywine' - red maple*Aesculus hippocastanum* 'Baumannii' – Baumann's horsechestnut*Prunus yedoensis* - Yoshino cherry*Quercus palustris* - pin oak*Tristania laurina* - swamp myrtle*Ulmus* 'Princeton' - American elm

## **NORTHSIDE WEST**

**Total # trees surveyed:** 772

**Vacant Sites:** 207

**Range of Planting Strip Widths:** 2-13 feet

### **Existing Trees:**

*Brachychiton populneus*

*Liquidambar styraciflua*

*Magnolia grandiflora*

*Pistacia chinensis*

*Platanus acerifolia*

*Pyrus calleryana*

With one of the largest tree populations, tree species in this neighborhood are fairly diverse with the largest single species being aristocrat pear. The Brisbane box, the second most frequent species, is similar to the pear in its distribution among the diameter classes. Most of the trees are less than 6" DBH, with a slightly larger number in the 6-12" class. The majority of the existing and vacant planting sites are 3 - 3.5 feet wide. A large number of the sites are 5.5 feet wide, which provides a generous growing space.

### **Planting Recommendations:**

*Carpinus betulus* 'Fastigiata' - fastigate hornbeam *Cercis canadensis* - eastern redbud

*Nyssa sylvatica* - black tupelo

*Pistacia chinensis* - Chinese pistache

*Jacaranda mimosifolia* - Jacaranda

*Podocarpus gracilior* - African fern pine

*Ulmus* 'Frontier' - Frontier hybrid elm

*Lagerstroemia* x 'Natchez' and 'Tuscarora' - crape myrtle

**PARK STREET NORTH****Total # trees surveyed: 69****Vacant Sites: 78****Range of Planting Strip Widths: 2-6 feet****Existing Trees:***Platanus occidentalis**Pyrus calleryana*

The 69 trees in the neighborhood are distributed between 10 species; of these, the most common one is Bradford pear. The majority of these trees are less than 6" DBH. There are 78 vacant growing sites that can supplement the existing tree population. However, a majority of these planted and vacant sites are three feet wide, suitable only for small to medium stature trees.

**Planting Recommendations:***Acer nigrum* 'Green Column' - black maple*Aesculus carnea* - red horsechestnut*Carpinus betulus* 'Fastigiata' - fastigate hornbeam*Ginkgo biloba* 'Fairmount' - maidenhair tree*Lagerstroemia* x 'Tuscarora' and 'Natchez' - crape myrtle*Prunus sargentii* 'Columnaris' sargent cherry*Prunus yedoensis* - Yoshino flowering cherry

## **SOUTH CENTRAL**

**Total # trees surveyed:** 616

**Vacant Sites:** 253

**Range of Planting Strip Widths:** 2-6 feet

### **Existing Trees:**

*Brachychiton populneus*

*Ceratonia siliqua*

*Geijera parviflora*

*Ginkgo biloba*

*Jacaranda mimosifolia*

*Ligustrum lucidum*

*Platanus acerifolia*

*Pyrus calleryana*

*Quercus rubra*

There is relatively even species distribution of the 616 neighborhood trees. Most of the vacant planting spaces are either 3 or 3.5 feet wide.

### **Planting Recommendations:**

*Koelreuteria bipinnata* - Chinese flame tree

*Nyssa sylvatica* - black tupelo

*Pistacia chinensis* - Chinese pistache

*Quercus shumardii* - Shumard oak

*Acer rubrum* 'October Glory' and 'Brandywine' - red maple

*Acer saccharum* 'Commemoration' - sugar maple

*Jacaranda mimosifolia* - Jacaranda

*Prunus yedoensis* - Yoshino cherry

*Quercus suber* - cork oak



**SOUTH SHORE**

This area seems to possess better growing site conditions than many other neighborhoods; a majority of the planting sites (both occupied and vacant) are 4.5 feet wide and only a small fraction of the sites are obstructed by overhead wires. Although these particular conditions might allow for more flexibility in species selection, this area is typified by constant high velocity winds and poor soil. Appropriate tree species are those that are adapted to seaside environmental factors and tolerant to alkaline bay fill soils, which are sometimes covered with a layer of sand. Due to similar environmental factors, tree selections for Bayview and South Shore neighborhoods were combined in one recommendation.

**Planting Recommendations:**

*Metrosideros excelsus* - New Zealand Christmas tree

*Tristania conferta* - Brisbane box

*Tilia tomentosa* 'Green Mountain' & 'Sterling' -  
silver linden

*Lagerstroemia* x 'Natchez' & 'Tuscarora' - crape myrtle

## WEST CENTRAL

**Total # trees surveyed:** 265

**Vacant Sites:** 66

**Range of Planting Strip Widths:** 2-6 feet

**Existing Trees:**

*Brachychiton populneus*

*Pistacia chinensis*

*Platanus acerifolia*

*Pyrus calleryana*

This neighborhood has deep soils capable of growing large trees. The two most popular species in this neighborhood are the bottle tree and the London plane; they make up 40% of the total population of 265 trees. A large proportion of both tree populations are larger than 6" DBH; bottle trees are heavily skewed in the 6-12" class, while London planes are skewed in the 18-24" class. The majority of all available planting sites are either 3 or 3.5 feet wide. The main east/west streets are discussed separately in the "Major Streets" section of this report. Recommendations made here are meant for the comparatively narrower north/south streets.

**Planting Recommendations:**

*Acer buergeranum* - trident maple

*Acer campestre* - hedge maple

*Aesculus x carnea* - red horsechestnut

*Koelreuteria bipinnata* - Chinese flame tree

*Magnolia grandiflora* 'Russet' and 'St. Mary' - southern magnolia

*Ginkgo biloba* 'Saratoga' and 'Fairmount' - maidenhair tree

*Podocarpus gracilior* - fern pine

*Tilia tomentosa* 'Green Mountain' and 'Sterling' - silver linden

**WEST END**

**Total # trees surveyed:** 550

**Vacant Sites:** 284

**Range of Planting Strip Widths:** 2-6 feet

**Existing Trees:**

*Brachychiton populneus*

*Cinnamomum camphora*

*Koelreuteria bipinnata*

*Pyrus calleryana*

The most frequent species in this population of 550 trees are Chinese flame tree, camphor, Brisbane box, and bottle tree. Enough vacant planting sites were identified (284) to increase the existing tree population significantly. The majority of the planting sites are three feet wide.

**Planting Recommendations:**

*Carpinus betulus* 'Fastigiata' - fastigate hornbeam

*Cercis canadensis* - eastern redbud

*Koelreuteria bipinnata* - Chinese flame tree

*Tristania laurina* - swamp myrtle

*Acer nigrum* 'Greencolumn' - black maple

*Acer rubrum* 'October Glory' & 'Brandywine' - red maple

*Aesculus hippocastanum* 'Baumannii' - Baumann's horsechestnut

*Ulmus* 'Princeton' - American elm

## WEST END CENTRAL

**Total # trees surveyed:** 80

**Vacant Sites:** 48

**Range of Planting Strip Widths:** 3-6 feet

**Existing Trees:**

*Brachychiton populneus*

*Pyrus calleryana*

This neighborhood is comprised of school grounds plus a mixture of apartments and older single-family homes. With only 80 trees in the neighborhood, bottle trees account for the majority. All of these trees are between 3 -18", with the majority being in the 6-12" DBH class. The majority of available planting sites are 3.5 to 5.5 feet wide, all generously sized growing spaces.

**Planting Recommendations:**

*Acer x freemanii* 'Autumn Blaze' - Freeman maple

*Acer saccharum* 'Commemoration' - sugar maple

*Jacaranda mimosifolia* - Jacaranda

*Podocarpus gracilior* - fern pine

*Quercus coccinea* - scarlet oak

*Quercus suber* - cork oak

*Lagerstroemia* x 'Natchez' and 'Tuscarora' -  
crape myrtle

**WEST END NORTH**

In 1989, all West End North trees were *Ficus* and were of small diameter—all but one of the trees were smaller than 3" DBH. This small size indicates that the trees were young and were newly planted in 1989. There are currently no planting sites available, and, therefore, no recommendations for improved planting schemes.

## WOODSTOCK

**Total # trees surveyed:** 150

**Vacant Sites:** 51

**Range of Planting Strip Widths:** 3-28 feet

**Existing Trees:**

*Acacia melanoxylon*

*Platanus acerifolia*

Of the 51 planting sites identified, 65% are 4.5 or 4 feet wide, which allows for planting larger-growing species that are not practical in other areas. Fourteen spaces are available in the wide tree lawn on the west side of Main Street.

**Planting Recommendations:**

*Aesculus hippocastanum* 'Baumannii' - Baumann's horsechestnut

*Podocarpus gracilior* - fern pine

**For small, constrained planting sites use:**

*Tilia tomentosa* 'Green Mountain' and 'Sterling' - silver linden

*Pistacia chinensis* 'Keith Davey' - Chinese pistache

### 1.3 / BUSINESS DISTRICTS OF ALAMEDA

Listed below are the appropriate plant selections for those commercial areas of Alameda not specifically addressed in either street or neighborhood plant selection discussions. The following trees can be pruned to allow for view corridors and growth above business signs:

**Planting Recommendations:**

*Acer nigrum* 'Green Column' - black maple

*Ginkgo biloba* 'Fairmount' - maidenhair tree

*Metrosideros excelsus* - New Zealand Christmas tree

*Quercus palustris* - pin oak

*Acer rubrum* 'Armstrong' - red maple

*Pyrus calleryana* 'Aristocrat' - flowering pear

*Lagerstroemia* x 'Natchez' and 'Tuscarora' - crape myrtle

**ABORICULTURAL  
BEST PRACTICES**

# **CHAPTER 2**



Street trees must be properly planted and maintained in order for them to be a beautiful, valuable, and safe asset to the community.

This section provides detailed tree care guidelines that should be strictly enforced by Alameda's Department of Public Works. The guidelines incorporate the industry's best practices as written by the International Society of Arboriculture (ISA), and include details on:

- New tree planting
- Buying high-quality trees
- Pruning young trees
- Pruning mature trees
- Mature tree care
- Proper mulching technique
- Tree removals
- Insect and disease problems
- Protecting trees under construction

## **2.0 / NEW TREE PLANTINGS**

### **PRIORITIZING NEW STREET TREE PLANTINGS**

New street tree plantings should be prioritized as follows, where #1 are the highest priority plantings and #4 are the lowest priority plantings:

1. When an existing street tree has been removed and the now-vacant site is deemed suitable for another tree
2. Along the major streets of Alameda, as identified in the 2008 Street Tree Inventory
3. In neighborhoods where the number of vacant sites is high
4. In neighborhoods where the number of vacant sites is low

The filling in of planter strips with hardscape cannot be done without design review approval and an encroachment permit. Design review approval shall only be granted if street trees within the affected area are all planted in inappropriate locations with 3x mature tree radius of open space on both sides of the tree, and if pedestrian traffic is sufficient to justify a wider sidewalk.

### **NUMBER OF STREET TREES PER PROPERTY**

The number of trees planted per property may vary somewhat, depending on the following factors:

1. Recommended spacing for selected tree species given mature dimensions
2. Proximity to street intersections and traffic control devices
3. Existing trees, shrubs, fences, and obstructions
4. Location of driveways, sidewalks, curbs, and gutters
5. Length of frontage
6. Utilities (lines and boxes)

### **Minimum Planting Dimensions**

These design guidelines were developed from industry best practices and aim to maximize the success of street tree planting in the public domain. It should be noted that these guidelines are for new trees only and do not apply to existing trees.

New trees to be located along the street can be planted with the following minimum clearances:

- Trees planted in the planter strips can be an obstacle to the safe passage of pedestrians. For this reason, tree planting should not occur in planter strips that are less than the recommended widths that are in the tree matrix. The Tree Matrix defines the minimum width for each species.
- No tree shall be maintained in such a position or placed as to obstruct or interfere with the minimum sight line standards: Vision shall be clear between the elevations of three (3) feet and fifteen (15) feet above the average street grade with a triangle measuring twenty (20) feet from the corner along the two street curb lines

or 5' from curb return, whichever is greater. This should create a 45 degree clear visibility triangle.

- New trees should be planted at a spacing of 20-40 feet, so that the crowns of mature trees will just touch.

**Small trees:** 20 feet to 26 feet spacing

**Medium trees:** 24 feet to 32 feet spacing

**Large trees:** 32 feet to 40 feet spacing

## PLANTING THE TREE

The ideal time to plant trees and shrubs is in the late fall or winter during the dormant season after leaf drop, or in early spring before budbreak. Weather conditions are cool and allow plants to establish roots in the new location before spring rains and summer heat stimulate new top growth. Before planting a tree, be sure that all underground utilities are located prior to digging.

If the tree that is being planting is balled or bare-root, it is important to understand that its root system has been reduced by 90 to 95% of its original size during transplanting. As a result of the trauma caused by the digging, uprooting, storage, transportation and planting process, these trees commonly exhibit what is known as "transplant shock". Containerized trees may also experience transplant shock, particularly if they have circling roots that must be cut. Transplant shock is indicated by slow growth and reduced vigor following transplanting. Proper site preparation before planting, coupled with good follow-up care, reduces the duration of the transplant shock and allows the tree to quickly establish in its new location. By carefully following the nine simple steps outlined below, the City can significantly increase the likelihood of survival of its street tree plantings. A detailed diagrammatic planting specification is located in Appendix 1.

**1.** Dig a shallow, broad planting hole. Make the hole three times the diameter of the root ball if possible, but only as deep as the root ball. A wide hole is important because the roots on the newly planted tree must push through surrounding soil in order to establish. On most planting sites in new developments, the existing soil has been compacted and is unsuitable for healthy root growth. Breaking up the soil in a large area around the tree provides the newly emerging roots more room to expand into loose soil to hasten establishment.

**2.** Identify the trunk flare, the point where the roots spread at the base of the tree. This point should be partially visible after the tree has been planted. If the trunk flare is not partially visible, remove soil from the top of the root ball until part of the trunk flare is visible.

**3.** Remove any container, burlap, fabric, wire, or string from the tree's root zone. Inspect the root ball for circling roots, which should be removed with sharp hand pruners or a pruning saw. All remaining roots should be heading away from the trunk of the tree.

**4.** Place the tree at the proper depth in the hole. Before placing the tree in the hole, check to see that the hole has been dug to the proper depth. The top-most

major root emerging from the trunk flare should be located at the soil surface when the tree is placed in the hole (see Figure 5.0). The majority of the roots on the newly planted tree will develop in the top 12 inches of soil; if the tree is planted too deeply, new roots will have difficulty developing because of a lack of oxygen. To avoid damage when setting the tree in the hole, always lift the tree by the root ball and never by the trunk.

Figure 2.0

**5.** Straighten the tree in the hole. Before backfilling, have someone view the tree from several directions to confirm that the tree is straight. Once backfilling has begun, it is difficult to reposition the tree.

**6.** Fill the hole gently but firmly. Fill the hole about one-third full, and then gently but firmly pack the soil around the base of the root ball. Fill the remainder of the hole, taking care to firmly pack soil to eliminate air pockets that may cause roots to dry out. Continue this process until the hole is filled and the tree is firmly planted. It is not recommended to apply fertilizer at the time of planting.

**7.** Stake the tree using one of the methods outlined in the planting specifications (Appendix 1).

**8.** Build a watering basin around the tree that is at least several inches in diameter greater than the root ball. Water the tree. Ensure that the root ball and filled soil are moist.

**9.** Apply mulch - when feasible - to the base of the tree. Mulch is simply organic matter applied to the area at the base of the tree. It acts as a blanket to hold in moisture, moderate soil temperature, and reduces competition from grass and weeds. Some good choices are shredded bark, nut shells, or wood chips. A 2- to 4-inch layer is ideal, as more than 4 inches may cause a problem with oxygen and moisture levels. When placing mulch, be sure that the actual trunk of the tree is not covered, as that may cause decay of the living bark at the base of the tree. A mulch-free area 1 to 2 inches wide at the base of the tree is sufficient to avoid moist bark conditions and prevent decay.

**10.** Provide follow-up care. Keep the soil moist but not soaked; overwatering is just as harmful as underwatering. Long gentle soakings are more effective than

large volumes of water applied quickly to the root zone. When the soil is dry below the surface of the mulch, it is time to water. Continue until mid-fall, tapering off for lower temperatures that require less-frequent watering. Prune any branches damaged during transport or planting. Wait to begin structural pruning until after a full season of growth in the new location.

### **STREET TREE MAINTENANCE AND AUTHORITY**

It is the authority of the Public Works Department to maintain all the public trees, and adjacent property owners should be forbidden to maintain these trees except to prevent imminent injury or damage to persons or property.

Tree maintenance by private homeowners or tree services should only be allowed through a permit system. This ordinance (23 - 3.2) should be clearly supported by amendments that set standards for proper planting and pruning, in order to tighten standards for the protection of City street trees. Ordinance changes should also require fencing of sensitive areas prior to construction and restriction of the areas where equipment and vehicles would be stored or driven. In addition, the ability to issue punitive fines should be established. Ordinance changes would add to construction costs, but the City would benefit by protecting City trees and avoiding the costs associated with repair and loss of trees.

Clear standards for the City's street tree canopy must be properly enforced in order for these changes to become ingrained within the residents' expectations. To address the growing need for adequate monitoring of tree code infringement, enforcement will be shared by PW and building department. PW will be responsible for enforcement in the public right of way where as the building department has authority to enforce protection of protected species on private property. Individuals who enforce city standards should be clearly trained to recognize code infractions.

## 2.1 / BUYING HIGH QUALITY TREES

Trees supplied for planting in Alameda must meet the following criteria (any tree not conforming to these standards will be rejected and a replacement will be required):

- **True to type:** The trees supplied and planted must be the species (and variety, where applicable) that the purchaser ordered.
- **Health and vigor:** The trees supplied must be healthy and vigorous at the time of delivery, exhibiting good annual branch growth and root structure.
- **Free from pests and disease:** Trees should not be diseased or show evidence of pest attack that could affect the long-term health of the tree or adjoining plantings.
- **Balance of crown:** This refers to the crown bulk on opposite sides of the stem axis, which indicates the tree's structural integrity and aesthetic qualities. Trees that have an asymmetrical crown (nominally an imbalance of > 20%) are generally undesirable.
- **Uniformity of growth:** Trees should be grown at a steady rate to produce a better quality tree with an even branch structure. Over-fertilization can often lead to irregular growth, which could cause aesthetic and structural problems.
- **Stem taper:** This is a measure of the tree's ability to be self-supporting. Trees with insufficient stem taper may need artificial support (staking) and are prone to damage by vandals and wind. Inadequate stem taper is generally a result of the tree not having enough space to grow at the nursery without the use of stakes.
- **Included bark:** If bark is folding into the joint or crotch of a tree as it grows (often due to damage), this may cause structural weakness that could increase the risk of limbs falling in a storm.
- **Apical dominance:** Tree species grown with a defined central leader will have an improved appearance and better structure. Trees that have been topped in the nursery and have several branches emerging from the same location on the trunk are less desirable.
- **Root division:** Strong root development will provide a sound structural base for the tree. Trees held at length in containers may produce too much secondary division, causing watering problems for the plant (i.e., hydrophobic).
- **Root direction:** Root distortion during a tree's development will cause future problems in the root system (e.g., spiraling roots in a small tree, if left untreated at planting, could strangle the developing roots).
- **Root ball occupancy:** It is important that the volume of the root ball at purchase be fully occupied by the root system and when shaking the root ball unsupported, at least 90% of soil volume should remain intact.
- **Non-suckering rootstock:** It is preferable that a naturally suckering tree species be grafted onto a non-suckering rootstock before planting.

- **Injuries:** Beware of injuries beneath trunk wraps. Never buy a tree without thoroughly checking the trunk. If the tree is wrapped, remove the wrap and inspect the trunk for wounds, incorrect pruning cuts, and insect injuries. Wrap can be used to protect the trunk during transit but should be removed after planting.

Nursery-grown trees come in the following three forms, which should be inspected carefully for the health of the root ball:

- **Bare-Root Stock:** Bare roots should not be crushed or torn. The ends of the roots should be clean cut. If a few roots are crushed, re-cut them to remove the injured portions; use sharp tools, make straight cuts, and do not paint the ends. The cuts should be made immediately before planting and watering.
- **Balled-in-Burlap Stock:** It should be possible to see the basal trunk flare. The flare is the spreading trunk base that connects with the roots. Root balls should be flat on top. Roots in soil in round bags often have many major woody roots cut or torn during the bagging process—avoid these trees. The diameter of the root ball should be at least 10 to 12 times the diameter of the trunk as measured 6 inches above the trunk flare.
- **Container-Grown Stock:** Roots should not twist or circle in the container. Remove the root ball from the container and inspect the exposed larger roots carefully to see whether they are twisting or turning in circles. Circling roots often girdle and kill other roots. If only a few roots are circling, cut them away with a sharp tool. Trunk flare should be obvious. Be on alert for trees planted too deeply in containers or trees “buried” in fabric bags. As with root-balled stock, it should be possible to see the basal trunk flare with container-grown plants. If the trunk flare has been buried, gently expose it before planting the tree, taking care not to damage the bark.

Circling roots on a container-grown tree

## 2.2 / PRUNING YOUNG TREES

Proper pruning is essential in developing a tree with a strong structure and desirable form. Trees that receive the appropriate pruning measures while they are young will require little corrective pruning when they mature. Assuming that the proper trees have been selected for each site, pruning young trees to improve branch structure is the most effective method of reducing maintenance costs as trees mature. At the time of planting, the only pruning that should be done is the removal of broken or dead branches. In the second growing season, minor pruning can be performed to remove branches with poor attachments. In subsequent years, selective pruning should be performed to achieve the proper spacing of branches.

Keep these few simple principles in mind before pruning a tree:

- Each cut has the potential to change the growth of the tree. Always have a purpose in mind before making a cut.
- Proper technique is essential. Poor pruning can cause damage that lasts for the life of the tree. Learn where and how to make the cuts before picking up the pruning shears.
- Trees do not heal the way people do. When a tree is wounded, it must grow over and compartmentalize the wound. As a result, the wound is contained within the tree forever.
- Small cuts do less damage to the tree than large cuts. For that reason, proper pruning (training) of young trees is critical. Waiting to prune a tree until it is mature can create the need for large cuts that the tree cannot easily cover.
- The belief that trees should be pruned when planted to compensate for root loss is misguided. Trees need their leaves and shoot tips to provide food and the substances that stimulate new root production. Unpruned trees establish faster and with a stronger root system than trees pruned at the time of planting.

### **Making the Cut**

Where a tree care worker makes a pruning cut is critical to a tree's response in growth and wound closure. For these reasons it is important to make pruning cuts just outside the branch collar. Because the branch collar contains trunk or parent branch tissues, the tree will be damaged unnecessarily if you remove or damage the branch collar. In fact, if the cut is large, the tree may suffer permanent internal decay from an improper pruning cut.



If a permanent branch is to be shortened, cut it back to a lateral branch or bud. Internodal cuts, or cuts made between buds or branches, may lead to stem decay, sprout production, and misdirected growth.

### Pruning Tools

When pruning trees, it is important to have the right tool for the job. For small trees, most of the cuts can be made with hand pruning shears (secateurs). The scissor-types, or bypass blade hand pruners, are preferred over the anvil type because they make cleaner, more accurate cuts. Cuts larger than one-half inch in diameter should be made with lopping shears or a pruning saw. Never use hedge shears to prune a tree. Whatever tool tree care workers use, make sure it is kept clean and sharp.



**Bypass pruning shears**

### Establishing a Strong Scaffold Structure

A good structure of primary scaffold branches should be established while the tree is young. The scaffold branches provide the framework of the mature tree. Properly trained young trees will develop a strong structure that requires less corrective pruning as they mature.

The goal in training young trees is to establish a strong trunk with sturdy, well-spaced branches. The strength of the branch structure depends on the relative sizes of the branches, the branch angles, and the spacing of the limbs. Naturally, those factors vary with the growth habit of the tree. Pin oaks and sweetgums, for example, have a conical shape with a central leader. Elms and live oaks are often wide-spreading without a central leader. Other trees, such as lindens and Bradford pears, are densely branched. Good pruning techniques remove structurally weak branches while maintaining the natural form of the tree.

### Trunk Development

For most young trees, it is important to maintain a single dominant leader growing upward. Do not prune back the tip of this leader, and do not allow secondary branches to outgrow the leader. Sometimes a tree will develop double leaders known as co-dominant stems. Co-dominant stems can lead to structural weaknesses, so it is best to remove one of the stems while the tree is young.

The lateral branches growing on the sides contribute to the development of a sturdy, well-tapered trunk. It is important to leave some of these lateral branches in place initially, even though they may be pruned out later. These branches, known as

temporary branches, also help protect the trunk from sun and mechanical injury, while reducing the need for fertilizing (more leaf area means more photosynthesis). Temporary branches should be kept short enough so that they do not obstruct or compete with selected permanent branches.

### **Permanent Branch Selection**

The strategy for training a young tree depends on its primary function in the landscape. Low branches, for example, often make a tree appear well-proportioned when young, but they are seldom appropriate for large-growing trees in an urban environment. Street trees must be pruned so that they allow at least 13.5' over roadways (15' if State Highway) of clearance for traffic, but most landscape trees require only about 8 feet of clearance. 15' is preferred in commercial area to avoid blocking street signs.

Newly planted trees should keep their lower temporary branches intact for as long as possible. Although they make the tree look a bit unruly, temporary branches and staking (due to tapered caliper) should be maintained for at least the first year.

The vertical and radial spacing of branches is very important. Branches selected as permanent scaffold branches must be well spaced along the trunk. Further, radial spacing of branches growing outward in each direction should be balanced. A good rule of thumb for the vertical spacing of permanent branches is to maintain a distance equal to 3% of the tree's eventual height. Thus, a tree that will be 50 feet tall should have permanent scaffold branches spaced about 18 inches apart along the trunk. Avoid allowing two scaffold branches to grow one above the other on the same side of the tree.

Some trees have a tendency to develop branches with narrow angles of attachment and tight crotches. As the tree grows, bark can become enclosed deep within the crotch between the branch and the trunk. Such growth, called "included bark," weakens the attachment of the branch to the trunk and can lead to branch failure when the tree matures. Tree care workers should prune branches with weak attachments while they are young.

Avoid over-thinning the interior of the tree. The leaves of each branch must manufacture enough food to keep that branch alive and growing. In addition, each branch must contribute food to nurture the trunk and roots. Removal of too many leaves can "starve" the tree, reduce growth, and make the tree unhealthy. A good rule of thumb is to maintain at least half the foliage on branches growing in the lower two-thirds of the tree.

## 2.3 / PRUNING MATURE TREES

Pruning is the most common tree maintenance procedure. Although forest trees grow quite well with only nature's pruning, landscape trees require a higher level of care to maintain their safety and aesthetics. Pruning should be done with an understanding of how the tree responds to each cut. Improper pruning can cause damage that will last for the life of the tree, or worse, shorten the tree's life.

### Reasons for Pruning

Because each cut has the potential to change the growth of the tree, no branch should be removed without a valid reason. Common reasons for pruning are to remove dead branches, to remove crowded or rubbing limbs, and to eliminate safety concerns. Trees may also be pruned to increase light and air penetration to the inside of the tree's crown. In most cases, mature trees are pruned as a corrective or preventive measure.

Routine thinning does not necessarily improve the health of a tree. Trees produce a dense crown of leaves to manufacture the sugar used as energy for growth and development, so removal of foliage through pruning can reduce growth and stored energy reserves. Heavy pruning can be a significant health stress for the tree.

Yet if people and trees are to coexist in an urban or suburban environment, we sometimes have to modify the trees. Safety is a major concern, as well as aesthetics—we want trees to complement other landscape plantings and lawns. Proper pruning, done with a clear understanding of tree biology, can maintain good tree health and structure while enhancing the esthetic and economic values of our landscapes.

### When to Prune

Most routine pruning to remove weak, diseased, or dead limbs can be accomplished at almost any time during the year with little effect on the tree. However, growth is maximized and wound closure is fastest if pruning takes place before the spring growth flush. Some trees, such as maples and birches, tend to "bleed" if pruned early in the spring. It may be unsightly, but it is of little consequence to the tree.

Heavy pruning just after the spring growth flush should be avoided. At that time, trees have just expended a great deal of energy to produce foliage and early shoot growth, so removal of a large percentage of foliage can stress the tree.

A few tree diseases, such as oak wilt, can be spread when pruning wounds allow spores access into the tree. Susceptible trees should not be pruned during active transmission periods.

### Making Proper Pruning Cuts

Pruning cuts should be made just outside the branch collar. The branch collar contains trunk or parent branch tissue that should not be damaged or removed. If the trunk collar has grown out on a dead limb that is to be removed, make the cut just beyond the collar—do not cut the collar.

If a large limb is to be removed, its weight should first be reduced in order to avoid tearing the bark. This is done by making an undercut about 12 to 18 inches from the limb's point of attachment. Make a second cut from the top, directly above or a few inches farther out on the limb. Doing so removes the limb, leaving the 12- to 18-inch stub. Remove the stub by cutting back to the branch collar.

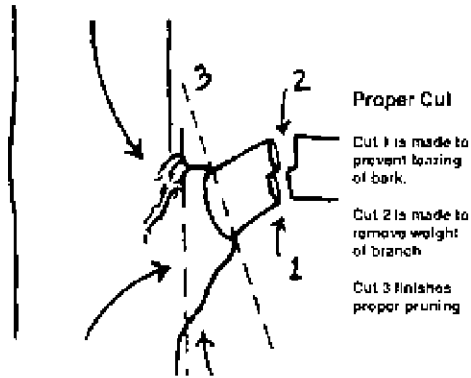

### Pruning Techniques

Specific types of pruning may be necessary to maintain a mature tree in a healthy, safe, and attractive condition.



Cuts made along a branch should be made at a lateral branch or bud.

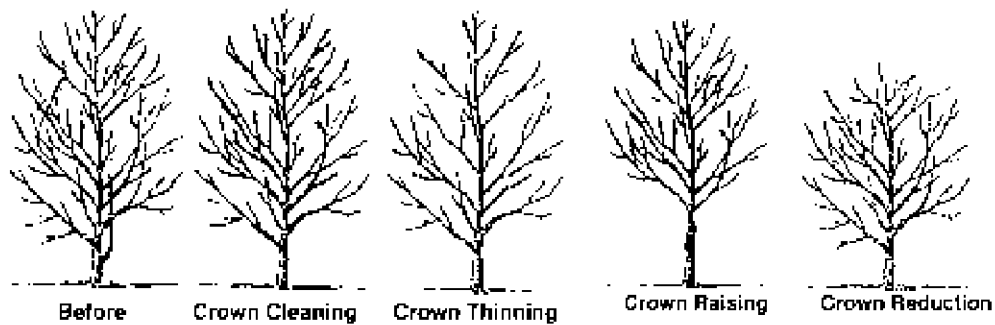

- **Cleaning** is the removal of dead, dying, diseased, crowded, weakly attached, and low-vigor branches from the crown of a tree.
- **Thinning** is the selective removal of branches to increase light penetration and air movement through the crown. Thinning opens the foliage of a tree, reduces weight on heavy limbs, and helps retain the tree's natural shape.
- **Raising** removes the lower branches from a tree in order to provide clearance for buildings, vehicles, pedestrians, and vistas.
- **Reduction** reduces the size of a tree, often to ensure clearance for utility lines. Reducing the height or spread of a tree is best accomplished by pruning back the leaders and branch terminals to lateral branches that are large enough to assume the terminal roles (i.e., at least one-third the diameter of the cut stem). Reduction is preferable to topping, as it helps maintain the form and structural integrity of the tree.

### **How Much Should Be Pruned?**

The amount of live tissue that should be removed depends on the tree size, species, and age, as well as the pruning objectives. Younger trees tolerate the removal of a high percentage of living tissue better than mature trees do. An important principle to remember is that a tree can recover from several small pruning wounds faster than from one large wound.

A common mistake is to remove too much inner foliage and small branches. It is important to maintain an even distribution of foliage along large limbs and in the lower portion of the crown. Over-thinning reduces the tree's sugar production capacity and can create tip-heavy limbs that are prone to failure.

Mature trees should require little routine pruning. A widely accepted rule of thumb is never to remove more than one-quarter of a tree's leaf-bearing crown, though pruning even that much could have negative effects on a mature tree. The older and larger a tree becomes, the less energy it has in reserve to close wounds and defend against decay or insect attack. Removing even a single large-diameter limb can create a wound that the tree may not be able to close. The pruning of large, mature trees is therefore usually limited to removal of dead or potentially high risk limbs.

### **Wound Dressings**

Wound dressings were once thought to accelerate wound closure, protect against insects and diseases, and reduce decay. However, research has shown that dressings do not reduce decay or speed closure, and they rarely prevent insect or disease infestations. Most experts recommend that wound dressings not be used.

### **Pruning Mature Trees**

Pruning is the most common tree maintenance procedure next to watering. Pruning is often desirable or necessary to remove dead, diseased, or insect-infested branches and to improve tree structure, enhance vigor, or maintain safety. Because each cut can change the growth of, or cause damage to a tree, no branch should be removed without a valid reason.

Removing foliage from a tree has two distinct effects on its growth: reducing photosynthesis and possibly reducing overall growth. Consequently, pruning should always be performed sparingly. Overpruning is extremely harmful because without enough leaves, a tree cannot gather and process enough sunlight to survive.

However, the growth that does occur after pruning takes place on fewer shoots, so they tend to grow longer than they would without pruning. Understanding how the tree responds to pruning should assist tree care workers when selecting branches for removal.

Pruning mature trees requires special equipment, training, and experience. If the pruning work requires climbing, the use of a chain or hand saw, or the removal of large limbs, then using personal safety equipment such as protective eyewear and hearing protection is a must. Arborists can provide a variety of services to assist in performing the job safely and reducing risk of personal injury and damage to residences and property. They also are able to determine which type of pruning is necessary to maintain or improve the health, appearance, and safety of City street trees.

Big cuts can result in decay and cracks

## **STREET TREE MAINTENANCE GUIDELINES**

**1.** Trees are to be pruned to develop proper structure, to improve health and vigor by deadwood removal, and for clearance of obstructing branches or foliage for pedestrians, bicycles, and vehicles. The intent of the trimming program is to prune trees for safety and health rather than cosmetic appearance. It is a Public Works Department policy NOT to pollard or top street trees because of the overall negative effect of these practices.

**2.** The Public Works Department will continue the program of regular street tree pruning and maintenance, where funds are available.

- a.** Any tree shall be top-pruned and the crown reduced by an appropriate amount PRIOR to any severe root pruning unless there is an immediate need to prune the roots. Root pruning and limb pruning should not occur in the same year.
- b.** Pruning shall take place under the guidance and direction of an arborist or recognized authority.
- c.** Regular pruning shall be done to thin and reduce the crown of any potential problem tree in order to reduce wind load.
- d.** All tools shall be disinfected if a diseased or infested tree is pruned or removed.

**3.** Utility companies shall operate in a manner to prevent damage to trees. Any person excavating in the public right-of-way shall not cut tree roots exceeding three inches without approval of a city “approved” arborist pruning. If this regulation is not followed, said party may be liable for tree damages and any subsequent damages from tree failure.

## **2.4 / MATURE TREE CARE**

### **Tree Inspection**

Tree inspection is an evaluation tool that calls attention to any change in the tree's health before the problem becomes too serious. If funding is sufficient by providing regular inspections of mature trees at least once a year, tree maintenance workers and supervisors can prevent or reduce the severity of future disease, insect, and environmental problems. During tree inspection, be sure to examine four characteristics of tree vigor: new leaves or buds, leaf size, twig growth, and absence of crown dieback (gradual death of the upper part of the tree).

A reduction in the extension of shoots (new growing parts), such as buds or new leaves, is a fairly reliable cue that the tree's health has recently changed. To evaluate this factor, compare the growth of the shoots over the past three years and determine whether there is a reduction in the tree's typical growth pattern.

### **Fertilization**

Fertilization may not be necessary for the first growing season unless there are specific nutrient deficiencies. At the beginning of the second growing season, fertilizers can be applied to the root zone. Nitrogen is usually the limiting nutrient for plant growth. Soil analysis, particularly when combined with a foliar analysis, can determine when other elements are in short supply. Slow-release fertilizers applied in autumn will help root growth and will continue providing nutrients the following spring. Mature trees should not be placed on a scheduled fertilization program without a documented need. If soil analyses show a distinct and serious nutrient deficiency, or if the tree's root system or growing area has been damaged or contaminated, then the time and expense of fertilization may be worthwhile to save the tree. A certified arborist can determine if and when public trees need fertilization as well as the appropriate fertilizer formulation and delivery method.

### **Tree surgery**

The requirement and extent of tree surgery should be determined on site by a certified arborist. Where tree surgery is considered necessary, give notice and obtain instructions. All pruning work should be in accordance with the International Society of Arboriculture Standards for Pruning.

### **Cabling and Bracing**

Rather than remove or severely prune a mature tree if a structural defect is discovered, the use of structural support can reduce safety risks on a case by case basis. Cabling and bracing are the two most common forms of structural support for trees; other, less common forms of structural support are guying and propping. Structural support is infrequently recommended, but trees with special or historic significance can be spared from removal by using such techniques as cabling and bracing.

### **Primary Uses of Cabling and Bracing**

**Prevention:** to reduce the chance of failure on a healthy tree with structural weakness (e.g., a specimen oak in good condition but having large limbs with V-crotches).



**Restoration:** to prolong the existence of a damaged tree (e.g., a large sugar maple that lost one of its leaders in a storm, leaving the others suddenly exposed and vulnerable to further damage).

**Mitigation:** to reduce the high risk potential of a tree (e.g., a picturesque multi-stemmed hickory that towers over a picnic shelter).

## **SPECIAL FERTILIZATION AND WATERING NEEDS IN ALAMEDA**

The following are guidelines for providing water, nutrients and companion plants to trees under common soil conditions in Alameda. It should be noted, however, that trees may exhibit a variety of responses to their surroundings, and regular monitoring is necessary to insure that the tree is receiving the water and nutrients it needs.

### **Irrigating Trees in Sandy Soil**

- Water generously 2 - 3 x per week on slow drip
- 20 gallons a week for 1st 2 years after planting
- 10 gallons a week for subsequent years
- The water you put in runs through the soil quickly. It travels straight down and does not spread to the side

Therefore, move your water source around in order to get all roots.

### **Fertilizing Trees in Sandy Soil**

- Add high-nitrogen organic fertilizers as needed, up to once per season. Organic fertilizers include fish emulsion, kelp powder and lawn clippings. Don't pile lawn clippings too thick- just sprinkle a thin layer and allow to dry thoroughly. Remember that the soil cannot hold onto these nutrients so don't overdo it, it will just run off.
- Keep a good layer of wood chips and/or compost in the tree basin. Do not pile the mulch up against the tree trunk as this can cause crown rot and kill your tree.

### **Providing Companion Plants to Trees in Sandy Soil**

Plants in the pea and bean family are nitrogen fixers (draw N from air and turn it into a usable form for plants). Other plants growing nearby can benefit from this. Annual plants in this family include:

- Climbing sweet pea (give the sweet pea something else to climb besides the tree!)
- Red clover
- Perennials such as native lupine shrubs

### **Irrigating Trees in Clay Soil**

- Water 10-15 gallons per week with a slow drip
- The heavier the soil, the less water it may need
- Watch to see how fast the water drains and avoid creating a swampy condition. Roots need oxygen as well as water

- Try not to step on, or dig in, the soil when it is wet, because you can squeeze the oxygen out of it
- If clay soil dries out too much, water may just puddle on the surface. Try to keep the soil evenly moist without flooding it

### **Fertilizing Trees in Clay Soil**

- Clay soil holds onto nutrients well, so you don't need to add chemical fertilizer
- Replenish mulch as often as needed to keep a thick layer. Do not pile mulch up against the tree trunk
- There is less of a need to add nitrogen than with sandy soil

### **Providing Companion Plants to Trees in Clay Soil**

Clay soil needs more oxygen, so choose plants with tough roots to break up the clay. Keep them from growing too close to the tree to avoid crown rot.

- Chrysanthemums
- Mints
- Tubers (e.g. Iris)

## **ALAMEDA'S MATURE STREET TREE MAINTENANCE PROGRAM**

An effective maintenance program, including regular inspections and the necessary follow-up care of mulching, fertilizing, and pruning, can detect problems and correct them before they become damaging or fatal. Considering that many tree species can live as long as 200 to 300 years, including these practices when caring for the trees in the City streetscape is an investment that will offer enjoyment and value for generations.

The decision to provide street tree maintenance should be based upon the following factors:

1. Public safety
2. Growth rate and structure of the individual tree
3. Time elapsed since last trimming
4. Geographic location

### **STREET TREE MAINTENANCE GUIDELINES**

1. Department policy is to minimize the use of pesticides and use them only when other methods have failed to control the disease or pests. The City will comply with the Bay Friends Landscape Ordinance with regards to pesticides use.
2. Based upon evaluation by Public Works personnel, the structurally corrective techniques of cabling and bracing may be employed. Roots may be shaved only under the direct supervision of an Arborist or Authorized City Staff.
3. Root pruning is done when tree roots are damaging City-owned infrastructure including sidewalks, curbs, gutters, sewers, and storm drains. The root pruning

program aims to mitigate all severe root-caused sidewalk damage. Priority of repair locations will be based on severity of damage and sidewalk traffic use. The following techniques may be used to mitigate infrastructure damage caused by tree roots:

**a. Root prune:** Roots are either pruned by hand or with the aid of a root pruning machine, which can be used 12 to 24 inches below grade on the sidewalk or curbside. Use of the root pruning machine is more cost effective but can result in severing large anchor roots. Root pruning is effective but may need to be repeated on a three- to four-year cycle to control re-sprouting of severed roots.

**b. Root prune with barriers:** Roots are pruned as in (a) above, but a rigid plastic barrier of variable depth may be installed to force roots down. This method can be effective providing the barrier is deep enough and the environment for root growth is suitable at the greater depth. It has been experimentally shown that roots will resurface after going under the barrier, but that the cycle between subsequent root prunings should be lengthened.

**c. Flexible root-controlling materials:** Materials such as Biobarrier and Root Shield are used to control root growth. Both contain encapsulated, time-released Treflan, an herbicide that controls root growth. Root Shield is a sewer gasket material used to prevent root penetration of sewers, while Biobarer is a geotextile fabric that is buried wherever an obstruction to root growth is desired.

**d. Material changes:** The use of materials that are more flexible and less expensive to maintain than concrete is another alternative in solving the sidewalk damage problem. Decomposed granite and asphalt were tried but met with resistance by the public due to the non-traditional appearance.

**e.** Addition of drainage rock directly under the sidewalk reduces the potential for water to reach under here to the bottom of the sidewalk and thus discourages new roots from establishing themselves in that zone.

**f. Design modification:** In areas where the amount of growing space is severely restricted, the technique of bowing sidewalks or gutters or providing breaks in curb to accommodate trunk expansion, in conjunction with the above controlling methods has had successful results. Sidewalk-curb reconstruction of a monolithic design shall not be used in Alameda.

**4.** The city will respond promptly to a safety concern when a public tree is involved.

**5.** The tree removal is permissible only after all practical and reasonable alternatives have been considered.

## **Reducing Infrastructure Damage by Tree Roots - Alternatives to Root Pruning**

### **Sidewalk cutouts**

- Minimizes the sidewalk width
- Maintain ADA accessibility
- Limited availability in Alameda

### **Sidewalk meandering**

- May require public easement from the property owner

### **Sidewalk ramping**

- Requires ADA compliance
- Not viable near driveways

### **Flexible Paving Materials**

- 3X Cost
- Changing industry standards
- Environmental concerns
- Increased frequency of lifting at joints
- Increased maintenance costs

### **Relocate Sidewalk to Parking Lane**

- Remove sidewalk from inside of treeline, and place on street side
- Eliminates parking along the entire block - only feasible where sufficient parking exists
- Only possible on wide streets
- Few viable streets in Alameda
- Only possible where parking demand is low

### **Hardscape Damage is Preventable at Planting**

- Select appropriate tree species
- Use larger planting spaces
- Increase distance from hardscape
- Also consider an extra layer of gravel under a repaired sidewalk to minimize new root growth directly under the sidewalk.
- Relocate curb into parking lane only where roadway width is sufficient and where drainage, travel lanes and parking space will not be impacted.
- Root shaving (as approved or directed by Arborist).
  - minimizes future sidewalk uplift without actually severing tree roots.
  - already used successfully as part of sidewalk repairs in Alameda.

## 2.5 / PROPER MULCHING TECHNIQUE

Mulches are materials placed over the soil surface to maintain moisture and improve soil conditions. Mulching is one of the most beneficial things that can be done for the health of a tree. Mulch can reduce water loss from the soil, minimize weed competition, and improve soil structure. Properly applied, mulch can give landscapes a handsome, well-groomed appearance; yet if it is too deep or if the wrong material is used, mulch can actually cause significant harm to trees and other landscape plants.

Mulching offers several benefits, especially for tree well-being. Trees that are properly mulched benefit from less drought stress and less root damage, and tend to grow faster and be more vigorous. Mulch also helps to hold moisture in the surface of the soil where most of the feeder roots are to be established.

Mulch should be applied to the surface of the soil around each newly planted tree. Mulch should never be piled up around the root collar (creating mulch volcanoes), but rather should be pulled away from the root collar. Mulch that buries the root collar provides shelter for insects, fungi, and mammals that could damage the tree. Mulch not only suppresses competition from grass and weeds, but it also provides a zone where turf maintenance is not needed, thereby keeping lawn mowers and string trimmers safely away and preventing mechanical damage. There are certain insect pests specifically drawn to wounded trees, and if a tree is already stressed, the additional injury can substantially reduce the tree's ability to sustain defense and maintain growth. A less visible impact is the effect on roots; decay from trunk damage can spread into the root system. It is recommended that all small diameter trees be mulched regularly. Large diameter trees should also be mulched where the mulch bed will not interfere with other uses of the area.

Generally speaking, mulch should be applied to an area three times the diameter of the root ball. As a rule of thumb, it is applied in a 2- to 4-inch layer in a 3-foot diameter circle around young trees and as far out as the drip line in mature trees. Mulch is placed in a saucer shape around the tree, meaning the outside edges are slightly higher than the inside, and it is never placed directly against the trunk. Application is usually once a year, as long as the 2- to 4-inch depth is not exceeded. When carefully and consistently applied, public trees will derive the benefits from mulch, avoid mechanical damage, and be more attractive.

### Types of Mulch

Mulch is available commercially in many forms. The two major types of mulch are inorganic and organic. Inorganic mulch can include various types of stone, lava rock, pulverized rubber, geotextile fabrics, and other materials that do not decompose and do not need to be replenished often. On the other hand, inorganic mulch does not improve soil structure, add organic materials, or provide nutrients. For these reasons, the city should only use organic mulches.

Organic mulches include wood chips, pine needles, hardwood and softwood bark, cocoa hulls, leaves, compost mixes, and a variety of other products usually derived from plants. Organic mulches decompose in the landscape at different rates depending on the material and climate; those that decompose faster must be replenished more often. Because the decomposition process improves soil

quality and fertility, many arborists and other landscape professionals consider that characteristic a positive one, despite the added maintenance.

### **Problems Associated with Improper Mulching**

- Deep mulch can lead to excess moisture in the root zone, which can stress the plant and cause root rot.
- Piling mulch against the trunk or stems of plants can stress stem tissues and may lead to insect and disease problems.
- Some mulches, especially those containing cut grass, can affect soil pH levels. Continued use of certain mulches over long periods can lead to micronutrient deficiencies or toxicities.
- Mulch piled high against the trunks of young trees may create habitats for rodents that chew the bark and possibly girdle the trees.
- Thick blankets of fine mulch can become matted and may prevent the penetration of water and air. In addition, a thick layer of fine mulch can become like potting soil and may support weed growth.
- Anaerobic "sour" mulch may give off pungent odors, and the alcohols and organic acids that build up may be toxic to young plants.

## 2.6 / INSECTS AND DISEASES

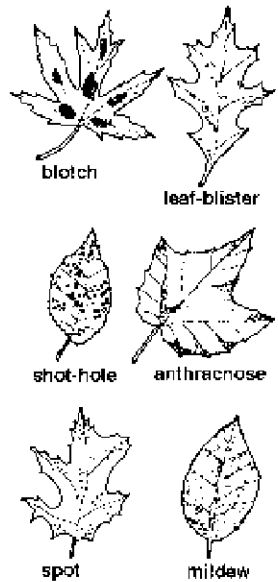

Insects and diseases can threaten tree health. Where possible, as soon any abnormality in a tree's appearance is observed, an order should be issued to begin a careful examination of the problem. By identifying the specific symptoms of damage and understanding their causes, staff may be able to diagnose the problem and select an appropriate treatment.

Street trees can be predisposed to insect and disease problems since they are growing in unnatural and constrained environments. Therefore, it is prudent to include insect and disease monitoring where possible as a routine part of a street tree inspection program. It is only when particularly damaging insects such as gypsy moth and emerald ash borer are detected, when the levels of insect populations are extremely high, or when particularly virulent diseases are diagnosed that action must be taken. The type and extent of action depends on the type and extent of the insect or disease problem.

### STRESS

Basic elements that influence plant health include sufficient water and light, and a proper balance of nutrients. Too much or too little of any of these environmental conditions may cause plant stress.

Environmental stress, such as air and water pollution, weakens plants and makes them more susceptible to insect and disease attack. Trees deal with environmental stresses, such as shading and competition for water and nutrients in their native environment, by adjusting their growth and development patterns to reflect the availability of the resources. Although trees adapt to living in stressful conditions in nature, the stresses they experience in the urban landscape are often more than they can handle, making them more susceptible to insects and diseases.

## DIAGNOSIS

Correct diagnosis of plant health problems requires a careful examination of the situation.

**1. Accurately identify the plant.** Because many insects and diseases are plant-specific, this information can quickly limit the number of suspected diseases and disorders.

**2. Look for a pattern within the abnormalities.** It may be helpful to compare the affected plant with other plants on the site, especially those of the same species. Differences in color or growth may present clues as to the source of the problem. Varied damage patterns may indicate insects or diseases, while uniform damage over a large area (perhaps several plant species) usually indicates disorders caused by such factors as physical injury, poor drainage, or weather.

**3. Carefully examine the landscape.** The history of the property and adjacent land may reveal many problems. The number of species affected may also help distinguish between infectious pathogens that are more plant-specific as compared to chemical or environmental factors that affect many different species. Most living pathogens take a relatively long time to spread throughout an area, so if a large percentage of plants becomes diseased virtually overnight, a pathogen is probably not involved.

**4. Examine the roots.** Note their color—brown or black roots may signal problems. Brown roots often indicate dry soil conditions or the presence of toxic chemicals. Black roots usually reflect overly wet soil or the presence of root-rotting organisms.

**5. Check the trunk and branches.** Examine the trunk thoroughly for wounds because they provide entrances for pathogens and wood-rotting organisms. Wounds can be caused by weather, fire, lawn mowers, and rodents, as well as a variety of other environmental and mechanical factors. Large defects may indicate a potentially high risk tree.

**6. Note the position and appearance of affected leaves.** Dead leaves at the top of the tree are usually the result of environmental or mechanical root stress. Twisted or curled leaves may indicate viral infection, insect feeding, or exposure to herbicides. The size and color of the foliage may tell a great deal about the plant's condition. Make note of these and any other abnormalities.

## DISEASES

Three things are required for a disease to develop:

- The presence of a pathogen (the disease-causing agent)
- Plant susceptibility to that particular pathogen
- An environment suitable for disease development

Diseases can be classified into two broad categories: those caused by infectious or living agents (diseases) and those caused by noninfectious or nonliving agents (disorders).



Examples of infectious agents include fungi, viruses, and bacteria. Noninfectious disorders, which account for 70 to 90% of all plant problems in urban areas, can be caused by factors such as nutrient deficiencies, temperature extremes, vandalism, pollutants, and fluctuations in moisture. Noninfectious disorders often produce symptoms similar to those caused by infectious diseases; therefore, it is essential to accurately distinguish between the two in order to give proper treatment.

## **INSECTS**

Some insects can cause injury and damage to trees and shrubs. By defoliating trees or sucking their sap, insects can retard plant growth; by boring into the trunk and branches, they interfere with sap flow and weaken the tree structure. Insects may also carry some plant diseases.

However, the insect problem is often secondary to problems brought on by a stress disorder or pathogen. It is important to remember that most insects are beneficial rather than destructive. They help with pollination or act as predators of more harmful species. Therefore, killing all insects without regard to their kind and function can actually be detrimental to tree health.

Insects may be divided into three categories according to their method of feeding: chewing, sucking, or boring. Insects from each group have characteristic patterns of damage that will help determine the culprit and the proper treatment. Always consult a tree care expert to determine the nature of the insect problem or the proper treatment.

Chewing insects eat plant tissue such as leaves, flowers, buds, and twigs. Uneven or broken margins on the leaves, skeletonization of the leaves, and leaf mining often indicate damage done by these insects. Chewing insects can be beetle adults or larvae, moth larvae (caterpillars), or many other groups of insects. Observing the damage they cause will help in identifying the pest insect.

Sucking insects insert their beaks (probosces) into the tissues of leaves, twigs, branches, flowers, or fruit and then feed on the plant's juices. Some examples of sucking insects are aphids, mealy bugs, thrips, and leafhoppers. Damage caused by these pests is often indicated by discoloration, drooping, wilting, leaf spots (stippling), honeydew, or a general lack of vigor in the affected plant.

Boring insects spend time feeding somewhere beneath the bark of a tree as larvae. Some borers kill twigs and leaders when adults feed or when eggs hatch into larvae that bore into the stem and develop into adults. Other borers, known as bark beetles, mate at or near the bark surface, and adults lay eggs in tunnels beneath the bark.

## **TREATMENT**

The treatment method used for a particular insect or disease problem will depend on the species involved, the extent of the problem, and a variety of other factors specific to the situation and local regulations. Always consult a professional about the nature of the problem or proper treatment.

## Mulching

One of the simplest and least expensive things that can be done for stressed street trees may also be one of the most effective. Applying a 2- to 4-inch layer of organic mulch such as wood chips, shredded bark, or pine needles over the root system of a tree can enhance root growth. The mulch helps condition the soil, moderates soil temperatures, maintains moisture, and reduces competition from weeds and grass. The mulch should extend as far out from the tree as practical for the landscape site. Do not apply the mulch any deeper than 4 inches, and do not pile it against the trunk.

## Improving Aeration of the Root Zone

**a. Drilling holes/vertical mulching:** Compaction of the soil and increases in grade both have the effect of depleting the oxygen supply to tree roots. If soil aeration can be improved, root growth and water uptake can be enhanced.



Holes drilled through the root system to improve aeration.

A common method of aeration of the root zone involves drilling holes in the ground. Holes are usually 2 to 4 inches in diameter and are made about 3 feet on center throughout the root zone of the tree. The depth should be at least 12 inches but may need to be deeper if the soil grade has been raised. Sometimes the holes are filled with peat moss, wood chips, pea gravel, or other materials that maintain aeration and support root growth. This process is called vertical mulching.

**b. Radial aeration:** More recent research has shown promising results with another method called radial aeration. Narrow trenches are cut with a compressed air gun in a radial pattern throughout the root zone. These trenches appear similar to the spokes of a wagon wheel. It is important to begin the trenches 4 to 8 feet from the trunk of the tree to avoid cutting any major support roots, and the trenches should extend at least as far as the drip line of the tree. If the primary goal is to reduce compaction, the trenches should be about 8 to 12 inches in depth. They may need to be deeper if the soil grade has been raised.

The narrow trenches can be backfilled with topsoil or compost, promoting greater root growth in the trenched area than in the surrounding soil. This treatment can give a tree the added boost it needs to adapt to the compacted soil or new grade. Vertical mulching and radial trenching are techniques that may improve conditions for root growth. If construction-damaged trees are to survive the injuries and stresses they have suffered, they must replace the roots that have been lost.

## 2.7 / PROTECTING TREES UNDER CONSTRUCTION

Trees are valuable assets. Unfortunately, when construction occurs in the name of progress, trees are often compromised in the process. Attempts to save trees during the construction process are often doomed unless protective measures are carefully implemented prior to, and strictly enforced during, construction. Trees are adversely affected both above and below ground by construction activities. Activities that damage trees during construction are trenching, soil compaction, and soil clearing and grading. Ultimately, a Tree Protection Plan should be developed specifically for all construction projects where trees are located. This project specific protection plan must note that protective street tree fencing shall be installed prior to any site work and that it be placed at, or outside of, the dripline to ensure survivability of existing street trees. It must also state that no site disturbing activities (e.g., cut, fill, parking, or material storage) shall take place inside the fenced area. To establish pruning limits the required Tree Protection Plan must diagram minimum height requirements of construction equipment and emergency vehicles for the construction site. An arborist, not construction personnel, should perform all pruning. Approved Tree Protection Plans that are not adhered to, and result in street tree damage or removal, should result in penalties for the construction contractor controlling the construction site.

### METHODS AND TREATMENTS TO MINIMIZE ROOT LOSS

Stripping a site of organic surface soil during mass grading must restrict stripping of topsoil around trees. Any woody vegetation slated for removal and adjacent to protected trees should be cut at ground level and not pulled out by equipment. This will prevent tree root injury. When construction plans call for lowering grade, scarifying, preparing sub grade for fills and/or structures, it is important to use retaining walls with discontinuous footings to maintain natural grade as far as possible from street trees. Where possible, in proximity to existing street trees, excavate to finish grade by hand and cut exposed roots with a saw to avoid root wrenching and shattering by equipment, or cut with root pruning equipment. Soil outside of the cut face can be removed by equipment sitting outside the drip-line of the tree. In preparation of sub grade for pavement, encourage paving materials that requiring a minimum amount of excavation (e.g., reinforced concrete instead of asphalt). Design construction traffic patterns to avoid heavy loads adjacent to trees (i.e., heavy load bearing pavement requires thicker base material and sub-grade compaction). Specify minimum sub-grade compaction under pavement within drip-line (i.e., extra reinforcement in concrete or geotextile under asphalt may be needed). In excavation for footings, walls, and/or foundations, design walls/ structures with discontinuous footings/pier foundations. Avoid slab foundations and use post and beam footings instead. Coordinate and consolidate trenching for utilities and/or drainage so that utility trench locations and timing are unified for different installation contractors. For utilities, excavate trenches by hand in areas with roots larger than 3 inches in diameter and tunnel under woody roots rather than cutting them where possible.

## **EXHIBIT 1 / TREE REMOVAL POLICY**

### **A. GENERAL TREE REMOVAL POLICY**

Although tree removal is a last resort alternative, there are circumstances when it is necessary. An arborist can help decide whether or not a tree should be removed. The City will remove street trees that are: dead; diseased with a rapidly spreading pathogen that poses an hazard to other trees; or presents an imminent threat to public safety or a declared public nuisance. In other cases, where application is made to remove a healthy tree, consideration will be based on the guidelines included in this policy. Tree removal within the public Right-of-Way for private projects will be included in the planning design review process for the project. Tree removal is permissible only after all practical and reasonable alternatives have been considered. There are three types of tree removal: those that do not require public posting as listed above, exempt tree removal and those that require public notice.

### **B. IMMEDIATE TREE REMOVAL-NOT POSTED**

Trees that will not receive public noticing or posting include the following:

1. The tree is dead or presents an imminent threat to public safety as determined by a certified arborist.
2. The tree is determined by a certified Arborist to be infected with a rapidly spreading pathogen, such as Dutch Elm disease, that poses an immediate hazard to other trees.

### **C. EXEMPT TREE REMOVAL**

Streetscape and other projects that have already received public input and City Council approval for tree removal will be exempt from posting.

### **D. POSTED TREE REMOVAL**

Prior to the removal of any tree, except as listed in sections B and C, the City will post a public notice, allowing anyone to protest the removal of the tree. In addition, the city will notify adjacent property owners and post a notice on the city's web page. If a protest is filed, a public meeting will be held as discussed in section E2. Any person aggrieved by the final decision of the Public Works Director may pay the applicable appeal fee and appeal to the City Clerk within two weeks of the Director's decision. No more than 5% of the street trees in any given block face will be removed per year unless a greater percentage is approved by the City Council. Removal is proposed when the Public Works Director determines any of the conflicts listed below cannot be remedied.

#### **1. Site modifications to be evaluated to resolve conflicts before tree removal is considered.**

- A. Modify private construction
- B. Root pruning/shaving
- C. Curb modification that provides for adequate drainage for entire block
- D. Reduce sidewalk width near trees yet maintain ADA requirements

- E. Meander sidewalk
- F. Ramp sidewalk
- G. Reduce curb width
- H. Curb breaks
- I. New technology to be evaluated as it develops

## **2. Types of conflicts**

- A. The tree is causing damage to private or public infrastructure that cannot be mitigated by practical and reasonable options as determined by an arborist.
- B. The tree is causing persistent sidewalk and ADA safety concerns and cannot be mitigated by practical and reasonable options as determined by an arborist.
- C. The tree has a disease other than in B2 above, or is in poor health.
- D. The implementation of a tree phasing plan is needed to replace existing trees with more suitable species. Phased tree removal will occur only after a good faith effort is made to adhere to the maximum yearly tree removal percentage noted above. A comprehensive tree removal and proactive replanting plan shall be prepared and approved by City Council for phased removal. Example of conditions that would justify a phased removal plan include: a cluster of dead or dying trees as a result of a pathogen, or segments of excessive and or frequent tree related infrastructure damage that would require a whole row of trees to be removed.
- E. The tree is in conflict with a private improvement plan. If a planning permit is required for the improvement, a street tree removal request must be identified on the planning permit application, which will require notification and removal approval as detailed in this policy prior to the planning permit being processed. All applications to the Planning Department for private improvements that impact the public Right-of-Way must include existing conditions within the public Right-of-Way on the submitted drawings. This includes trees, utility boxes, streetlight and other structures in the public Right-of-Way.
- F. The removal is required to allow for the construction of public improvements when in consultation with an arborist, it is determined that there is no practical and or reasonable alternative available to retain the tree(s).

## **3. Tools that may be used to evaluate trees posted for removal.**

- A. Variables to be evaluated as part of tree removal decision.
  - 1. Biological impacts of tree removal (see Volume 1, Appendix 4 "Protection of Important Nesting Habitat")
  - 2. Tree Species characteristic
    - a. Climate adaptability
    - b. Growth characteristic
    - c. Soil adaptability
    - d. Resistance or tolerance to insects, diseases and other environmental conditions
    - e. Tree is a rare or unusual species in Alameda
    - f. Tree is an especially good example of its type in Alameda
  - 3. Condition of target tree's roots, branches, trunk, foliage
    - a. Structural Integrity
    - b. Tree general health

4. The tree's potential to reach mature height
  - a. Trees reach an economic and aesthetic height at maturity. Each tree species has a different optimal tree height and age. Site condition can enhance or reduce height potential.
5. The target tree is one of a limited number of large trees (i.e. trees over 40' tall) within the impact area. An impact area is defined as a distance equal to double the height of mature species.
6. The tree species is uniquely suited to the site or alternatively the optimal value is decreased at specific site.
  - a. Urban Habitat/Urban forest
  - b. Environmental tolerance
  - c. Property value
7. Value of tree as compared to cost to repair private and public damage by tree
8. Liability associated with tree.
9. Compliance with regulatory requirements, such as ADA
10. Value of tree as compared to future maintenance cost. A value analysis may be provided by an arborist on trees where the site cannot be modified and further analysis of the tree's impact is needed.

B. The model upon which the value analysis was developed is "A Guide for Plant Appraisals " published by the International Society of Arboriculture. A similar document may be used as the basis for value analysis. The variables listed above are to be considered when conducting the value analysis.

## **E. NOTIFICATION, PROTEST, APPEAL, REMOVAL, AND REPLACEMENT PROCEDURES**

### **1. Notification Procedure**

The Public Works Department shall not remove any street tree listed above in Section D, without first:

- a. Posting said tree with a conspicuous notice, and
- b. Notifying in writing the adjacent property owner and
- c. Posting on the City's web page

The notice and letter must be dated three weeks before any action is taken. The notice and letter must contain the reason for the removal. A copy of this policy, which describes the protest and appeal procedure, will be available upon request and on the City's web page.

### **2. Protest Procedure**

Any resident or property owner can protest the removal of a street tree by writing to the Public Works Director no later than three weeks from the date of posting. In the event of a protest:

- a. The Public Works Director shall stop any removal action and reconsider the removal decision.

- b. If the Public Works Director and the citizen lodging the protest cannot reach an agreement, a public hearing date will be identified within two weeks. All concerned parties can attend this hearing and present evidence or testimony.
- c. After the meeting, the Director shall notify all concerned parties of his decision, in writing, within approximately two weeks after the hearing.

### **3. Appeal Procedure**

Any resident or property owner can appeal the decision of the Public Works Director by writing to the Public Works Director or City Clerk, c/o City Hall. All appeals go before the City Council. There is an appeal fee, which is listed in the Master Fee Schedule.

### **4. Removal Procedure**

- a. If there is an appeal, the tree shall not be removed until the City Council has made the final decision. All Council decisions are final and not open to further appeal.
- b. Any tree that is removed shall be replanted with a suitable replacement, provided the new site is in accordance with MSTP spacing criteria. If the tree site is not suitable, the nearest suitable site that complies with Appendix 3 "Preferred Distances Between City Infrastructure and Replacement trees" will be used.

## **F. PROTECTED TREE REMOVAL POLICY**

No protected tree within the Public Right of Way shall be removed without a certificate of approval from the Historical Advisory Board. Protected trees shall include: the Palm trees in the public right of way on Burbank Street and Portola Avenue; any street tree on Thompson and Central Avenues; and any Coastal Live Oak (*Quercus agrifolia*) with a ten inch or greater diameter measured 4.5 feet above the ground. Applicants shall submit an arborist's report in a case where the health of the tree is the reason for the requested removal of the tree, or a contractor's report in a case where damage to foundation or other structure is the reason for the requested removal. Any protected street tree shall be replaced, at the applicant's expense, except those shown to be unhealthy or causing damage to private structures, to the satisfaction of the Public Works Director. Any Oak tree shall be replaced with a minimum of two Oak trees at sites in accordance with MSTP spacing criteria, 15 gallons or larger and to the satisfaction of the Planning and Building Director. (Alameda Municipal Code Sections 13 - 21.7)

## **G. REPLACEMENT PROCEDURE**

- a. In general, trees removed for cause shall be replaced within 60 to 90 days with the same or approved species, in containers no smaller than 15 gallons.
- b. Tree species will be selected so that curb or sidewalk damage will be minimized.
- c. The property owner will be notified that a new tree will be planted and that they will be responsible to water the tree.
- d. The standard procedure is to install a special perforated pipe next to the new plantings, where soil conditions warrant, in accordance with tree planting guidelines.

**EDUCATION**

# **CHAPTER 3**



### **3.0 / COMMUNITY OUTREACH AND EDUCATION**

A well-directed education and outreach program begins with the community's recognition of the benefits the urban forest provides. This allows maintenance requirements to be understood in the context of the quality of trees and the health of the urban forest as a whole. Increased awareness of our standards for tree care help promote the implementation of current regulations and build advocacy. Clear communication among property owners, developers, and staff is necessary to ensure that all tree-related practices are of the highest standards. In addition, members of the community will appreciate how their actions on street trees may affect the urban forest and the benefits it provides.

The MSTP proposes a variety of methods for public outreach. If budget allows staff are encouraged to give tree care presentations regularly to a broad range of community groups and to work closely with tree care professionals. The City of Alameda Department of Public Works Street Tree Web site should also become a valuable source of information on tree care, planting programs, available resources, and who to contact for tree information.

#### **OUTREACH**

The City of Alameda has an important role in fostering residents' understanding of the environmental, economic, and community benefits of street trees, as well as proper methods of tree selection, planting, and care. As funding allows the City's Public Works department should continue to provide planting and removal information through the City's Web site, through other local media publications, and during volunteer events. Different departments within the City should communicate with the public about tree-related issues pertinent to their specific missions. For example, City Planning provides information on tree planting and protection requirements during development, while Public Works provides information about tree selection, care, and permit requirements in the rights-of-way. Training should be a prerequisite for receiving neighborhood tree-planting funds for planting trees under the direction of the PW Department in the rights-of-way.

Although the City has created a good foundation in these areas of outreach, the City of Alameda Building and Planning Department oversees private property issues, Recreation and Park Department has authority over park trees, Department of Public Works maintain the Street Tree Program and the Historical Advisory Board has authority to approve removal of protected trees. Because several departments manage different tree issues it is difficult for residents to know exactly who to contact with questions.

#### **COMMUNITY OUTREACH AND COMMUNITY EDUCATION AT LARGE**

The City of Alameda's street tree program should to be linked to the community, whose collective decisions have a cumulative impact on the vitality of the City's street trees. Educating and involving as much of the community as possible in enhancement and maintenance increases community awareness of the benefits of trees while encouraging support of the urban forest's long-term health and growth. If funding

exists Alameda's Public Works department shall develop educational tree planting and tree care information programs. Ways to enhance the programs include:

- Develop an Arbor Day program that focuses on partnerships with elementary schools.
- Expand educational opportunities during large civic events.
- Develop a tree steward program to enlist PW volunteers in the maintenance of young trees.
- Establish a program to partner with the PW Department to develop neighborhood "trained block captains" to advise, assist, and educate residents throughout the community on proper tree maintenance and the importance of trees, and to encourage new plantings.

## **EDUCATIONAL TOOLS**

An important element of any successful urban forestry program is education. Governments and nonprofit organizations can work together to educate and inform property owners on how to plant and maintain their trees, and how to engage in development projects in ways that existing street trees. The educational tools discussed in this section are proven approaches to protecting urban street trees. Although implementing any of the recommendations previously described will require additional funds and a substantial effort, education and information dissemination are critical to the success of these efforts.

The measures discussed involve increasing awareness of many lesser known benefits and issues, including:

- 1.** Street trees provide public and private health and safety benefits and are natural mechanisms to reduce many problems.
- 2.** Street trees are not just attractive landscape decoration for people and habitat in which wildlife can live; they are an essential part of Alameda's natural heritage.
- 3.** Street trees can be protected through both city ordinances and guidance; not all street tree protection strategies have to be legislated. Incentives and education can greatly promote proper street tree stewardship throughout the City and across the island.
- 4.** All activities have some level of impact on our natural resources, and Alameda's residents have a personal responsibility to help their street trees. Education topics should range from the scientific inventory data gathered on Alameda's urban forest to more basic, consumer-oriented tree care, planting, and benefits information. The educational efforts should be offered to the following persons and groups:

**Citizen Groups**

**Building Inspectors**

**City Council**

**APT Contractors**

**City Contractors/Subcontractors**

**Realtors**

**Home/Property Owners**

**Developers**  
**Homeowner Associations**  
**Landscape Architects**

**Citizen Education Program** The goal of the Citizen Education Program is to increase knowledge regarding the importance of street trees and a sustainable urban tree canopy, as well as teaching maintenance and irrigation methods for existing trees within the City of Alameda. Urban forestry education can be provided to adults through Citizen Forester Workshops in partnership with local nonprofits and to youth through hands-on environmental education programs.

**Adult Community Workshops** Citizen Forester Workshops could empower and support community leaders and citizens alike to take personal responsibility for their urban forests by educating, training, and supporting citizens to plant and care for trees in their neighborhoods, thereby dramatically increasing tree survival. The program can be modeled after a highly successful urban forestry program in Los Angeles created by Tree People. That program boasts a 93% tree survival rate—an exceptional statistic for urban trees. The program utilizes and builds upon partnerships with successful government and nonprofit programs such as adopt-a-tree and hands-on tree care programs. The City of Alameda could work with community-based organizations to create an annual calendar of citizen education workshops to be held at parks, City offices, and community organizations.

## **YOUTH COMMUNITY WORKSHOPS**

**Youth Community Workshop** model is an after-school program that provides youth with opportunities to engage in citywide projects and pursue hands-on learning. The program could integrate hands-on urban forestry education into existing City of Alameda Recreation Department after-school programs throughout the City of Alameda. The City of Alameda may work with the local community-based organizations, and the Parks and Recreation Department to expand the already established local best practice model.

**Community Framework Assessment** A sustainable street tree program is a community asset that requires citizen input and volunteer participation. Community appreciation for the benefits and needs of street trees and engagement in planning, planting, and caring for street trees is essential to the long-term health of the this program. Without the active support and engagement of the community, urban street tree programs cannot succeed. This section describes the ways the community is currently informed about and participates in stewardship of the urban street trees.

## **PLANNING AND POLICY DEVELOPMENT**

Alameda residents have opportunities to participate in street tree planning and policy development through public comment during major plan development, through participation in oversight and planning committees, and through the Planning Board. The planning board listens to citizen comments at board meetings and development workshops. Public Works has encouraged public involvement, including the request for public input on tree planting and maintenance programs as well as notifica-

tions of all tree removals. As the street tree master plan is implemented continuous outreach to the public is encouraged.

Volunteer Opportunities Neighborhood and civic groups are the major source of citizen involvement in tree planting and stewardship. Across the country, citizens involved in community outreach and volunteering praise and support these planting programs, but maintain that a successful community street tree planting and maintenance program must provide sufficient maintenance funds and materials for the post-planting period.

## **PARTNERSHIPS**

Early in Alameda's history, a few people of vision rallied an entire city behind funding and building the foundation of Alameda's street tree and park system. In more recent times, in addition to working with neighborhood volunteers on tree programs, the City continues to partner with individual businesses, chambers of commerce, nonprofit organizations, the media, neighborhood councils, business improvement districts, and state and federal agencies. These partnerships illustrate that street trees and urban forestry is about community as much as it is about trees. The City of Alameda may therefore play an active role in the formation of a local nonprofit tree organization. Via contract, the staff at the nonprofit tree organization can organize volunteer recruitment, citizen forester training, and supervision support for City tree programs.

## **PUBLIC AWARENESS CAMPAIGN**

Developing a sustainable street tree canopy requires educating the residents, local businesses, and developers of the value of learning more about trees and the Alameda street tree programs. The public awareness campaign should have several facets, including a unified marketing plan, a City Web site dedicated to "tree issues," and planting packets. The public awareness campaign could also create an Alameda Tree Person Award to recognize the best developer, neighborhood manager, contractor, or government employee who excels at street tree protection and reforestation, as well as a Blue Ribbon Tree Contest awarding the best tree in the city as part of Arbor Day events and programs.

## **MARKETING CAMPAIGN**

Marketing materials could be developed with content guidance generated from the MSTP and the technical support of delegated volunteers. The content could be linked to a citywide marketing plan that would also integrate the distribution of planting packets to accompany newly planted street trees. A series of public service documents could be developed addressing a variety of "tree topics," including proper maintenance of trees, water conservation, healthy living environments, and the benefits of planting trees. The topic of "Healthy and Safe Trees" could be emphasized to dispel "tree myths." For example, many residents currently believe that trees, fruit, seeds, and leaves can be dangerous by leading to the destruction of property and creating unsafe walking conditions. The campaign could educate the public on planting the appropriate trees in different locations to minimize their negative impacts.

## CITY WEB SITE

The City's Web site could have a page dedicated to providing information to the public regarding the City Master Street Tree Plan. The Web site could include information provided in tree planting packets and marketing materials, and could serve as a one-stop location for all information regarding tree plantings and removals. Any tree management website should include the Alameda Approved Tree Matrix and other necessary regulations. Additionally, a link to a read-only GIS map made available for citizens to review, make comments, and update through an online form. The form would include the tree's number and the corrections. This "open-source" GIS map could encourage citizens to actively understand Alameda's street tree program.

Citizens could also be able to register their contact information online in order to receive notification via e-mail on tree planting events, workshops, and regular "City of Alameda Green Updates."

## DOOR HANGERS, EASEMENT FORMS, AND TREE PLANTING KITS

Prior to planting or removing a tree, Public Works employees or Maintenance Staff should leave door hangers outside residences so that residents can express a preference to a specific tree without City staff needing to meet residents in person.

Additionally, easement forms for sidewalk relocation or interior street tree species plantings could be developed to streamline the paper work necessary to provide different planting solutions for residents. When new trees are planted in front of residents' houses residents and homeowners could receive a tree planting packets. Packets could also be available at City of Alameda Public Works offices and other select locations. Packets could include contact information and brochures from all tree partners, seed packets, and coupons from local hardware stores and nurseries to purchase trees, tree care products, and landscaping materials at a discounted cost. Some brochure examples may include:

- Caring for your new tree
- Watering street trees
- How trees grow old
- How to kill a tree
- What do trees hate?
- What's so special about trees?

## EDUCATION AND OUTREACH RECOMMENDATIONS

As funding allows, the city should:

1. Continue to pursue outside training and arborist certification opportunities for staff, including the most up-to-date training in high risk tree identification, tree protection, and plant appraisal.
2. Develop a "one-stop shopping" comprehensive Web site for tree information. Property owners, developers, and citizens could use the site to find out how trees

affect them and how they affect trees. Access to important information regarding the City's Approved Tree Matrix, regulations, and programs should be available, as well as read-only access to the GIS tree inventory data to encourage public inventory review.

- 3.** Maintain a public presence at fairs and farmer's markets, and continue to hold events such as panel discussions and informational presentations for the community.
- 4.** Continue to partner with city nonprofit organizations and other tree professionals in education and outreach efforts.
- 5.** Expand upon and increase the availability of the City's street trees related literature.
- 6.** Create a Citizen Forester citizen education program.
- 7.** Partner with a nonprofit to develop tree planting volunteer programs.
- 8.** Create an Arbor Day program.
- 9.** Create a planting packet with coupons, seed packets, and tree care information.
- 10.** Create an annual Tree Person award and a Blue Ribbon Tree award.



## APPENDICES



# APPENDIX 1 / STREET TREE PLANTING AND STAKING SPECIFICATIONS

1. ALL WORK SHALL BE PERFORMED BY PERSONS FAMILIAR WITH THIS TYPE OF WORK AND UNDER THE SUPERVISION OF A QUALIFIED PLANTING FOREMAN.
2. CONTRACTOR SHALL VERIFY THAT ADEQUATE DRAINAGE EXISTS PRIOR TO PLANTING.
3. CONTRACTOR SHALL VERIFY THE LOCATION OF ALL UTILITIES PRIOR TO PLANTING.
4. TREES SHALL BE 7 TO 10 FEET HIGH SUPPLIED IN FIFTEEN GALLON CONTAINERS. TREES SHALL HAVE A MINIMUM OF 1.5 INCH TRUNK DIAMETER AT BREAST HEIGHT.
5. ALL TREES SHALL CONFORM TO THE STANDARDS SET FORTH IN THE MOST RECENT AMERICAN STANDARDS FOR NURSERY STOCK PUBLISHED BY THE AMERICAN ASSOCIATION OF NURSERYMEN (A.A.N.).
6. TREES SHALL HAVE A STRAIGHT STRONG TERMINAL LEADER, UNCLUT AND UNBROKEN. THE MAIN TRUNK SHALL HAVE ACCEPTABLE LATERAL GROWTH ALONG ITS LENGTH SHORTER AND SMALLER IN DIAMETER THAN THE MAIN TRUNK.
7. ALL TREES THAT, IN THE OPINION OF THE CITY ENGINEER, ARE DISEASED, INSECT INFECTED, OR HAVE GIRDLING ROOTS, WILL BE REJECTED.
8. TREES WITH ROOT FLARE COVERED BY MORE THAN 1.5 INCHES OF SOIL WILL BE REJECTED PRIOR TO INSTALLATION.
9. PLANTING MIXTURE FOR THE BACKFILL SHALL HAVE NO SOIL AMENDMENTS.
10. IN PARKWAY STRIPS SET PLANTER TOP 1.5 INCHES BELOW SIDEWALK GRADE. IN LAWNS OR GROUND COVER AREAS SET PLANTER TOP FLUSH WITH FINISHED GRADE. IN LAWN AREAS THERE SHALL BE A 2 FOOT MULCH RING CLEARANCE BETWEEN EDGE OF LAWN AND TREE.
11. STAKING OF TREE IS NOT RECOMMENDED, EXCEPT ON WINDY SITES, FOR LARGE EVERGREEN TREES, OR IN AREAS WITH HEAVY TRAFFIC. IF STAKING IS DONE, FLEXIBLE HOSE - NOT TIES AND WIRES - SHOULD BE USED. NAIL FLEXIBLE TREE STRAP TO EACH SIDE OF THE STAKE IN TEARDROP FIGURE WITH 1 INCH MAX GALVANIZED ROOFING NAIL.
12. TREE STAKES TO BE REMOVED AFTER TWO YEARS.
13. AT PLANTING PRUNE ONLY CROSSING LIMBS, CO-DOMINANT LEADER, BROKEN, DISEASED OR DEAD BRANCHES, AND ANY BRANCHES THAT POSE A HAZARD TO PEDESTRIANS WHILE PRESERVING FORM AND CHARACTER OF TREE. DO NOT CUT LEADER. DO NOT PRUNE IN ORDER TO REDUCE CANOPY SIZE.
14. DO NOT WRAP TRUNK OF TREE.
15. A ROOT COLLAR EXCAVATION FOR ALL TREES SPECIFIED WILL BE DONE BY THE CITY ENGINEER TO ENSURE THAT TREES WERE NOT PLANTED OR GROWN TOO DEEPLY AT THE NURSERY. LANDSCAPE CONTRACTORS SHALL HAVE SUPPLIERS MARK GROUND LEVEL LINE ABOVE ROOT BALL. IF CITY ENGINEER DETERMINES THAT THERE IS EXCESSIVE SOIL OVER THE ROOT CROWN, THE TREES WILL BE REJECTED.
16. MULCH SHALL BE 3" DEEP UNLESS OTHERWISE NOTED.
17. TREES SHALL BE WATERED TWICE WEEKLY. ALL TREES NOT MEETING WITH THE APPROVAL OF THE CITY ENGINEER AT THE END OF THAT PERIOD SHALL BE REPLACED BY THE CONTRACTOR.
18. DEEP WATERING TUBES.

## 1 TREE PLANTING NOTES

NO.	REVISED	BY	APP.
DATE: AUGUST 24, 2008			
SCALE: NOT TO SCALE			

<b>CITY OF ALAMEDA</b> CALIFORNIA ENGINEERING DEPARTMENT	<b>Tree Planting Details</b>	APPROVED BY: _____ CITY ENGINEER REG. C.E. NO. _____ DATE _____
--	------------------------------	---

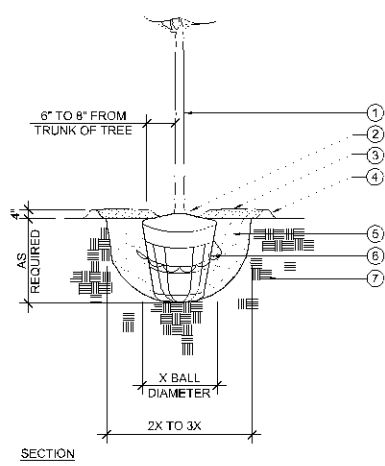

**LEGEND**

1. TREE TRUNK (OPTIONAL)
2. ROOTBALL CROWN TO BE 2" ABOVE SURROUNDING FINISH GRADE.
3. 3" MULCH RING DIRECTLY OVER PLANTING HOLE (KEEP CLEAR FROM TRUNK - DO NOT MOUND BASE OF TREE)
4. PLANTER SAUCER EDGE.
5. PLANTING MIX OR BACKFILL.
6. WIRE BASKET (OPTIONAL)
7. EXISTING SOIL.

**NOTES**

- A. CUT AND REMOVE TOP 1/2 OF WIRE BASKET, TURN DOWN TOP 1/2 OF BURLAP; REMOVE ALL CORD & TWINE FROM BASE OF TRUNK; IF NONDEGRADEABLE WRAP IS USED, REMOVE TOTALLY.
- B. LOOSEN EXTERIOR OF THE ROOT BALL AND THE ROOT MATT AT THE BOTTOM OF THE BALL, CUT ALL MAJOR CIRCLING ROOTS.

**2 GENERAL TREE PLANTING**

NO.	REVISED	BY	APP.

DATE: AUGUST 24, 2008  
SCALE: NOT TO SCALE

**CITY OF ALAMEDA**  
CALIFORNIA  
ENGINEERING DEPARTMENT

**Tree Planting Details**

APPROVED BY:  
\_\_\_\_\_  
CITY ENGINEER  
REG. C.E. NO. \_\_\_\_\_  
DATE \_\_\_\_\_

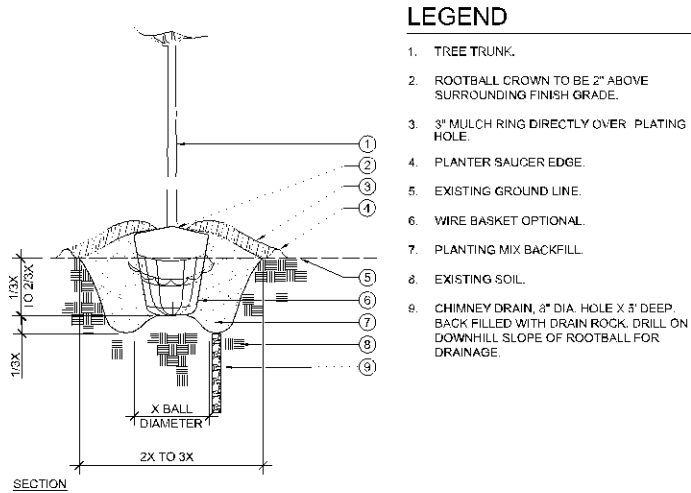

**LEGEND**

1. TREE TRUNK.
2. ROOTBALL CROWN TO BE 2" ABOVE SURROUNDING FINISH GRADE.
3. 3" MULCH RING DIRECTLY OVER PLANTING HOLE.
4. PLANTER SAUCER EDGE.
5. EXISTING GROUND LINE.
6. WIRE BASKET OPTIONAL.
7. PLANTING MIX BACKFILL.
8. EXISTING SOIL.
9. CHIMNEY DRAIN, 3" DIA. HOLE X 3' DEEP. BACK FILLED WITH DRAIN ROCK. DRILL ON DOWNHILL SLOPE OF ROOTBALL FOR DRAINAGE.

**3 TREE PLANTING IN WET / HEAVY SOILS**

NO.	REVISED	BY	APP

DATE: AUGUST 24, 2008  
SCALE: NOT TO SCALE

<p><b>CITY OF ALAMEDA</b> CALIFORNIA ENGINEERING DEPARTMENT</p>	<p>Tree Planting Details</p>	<p>APPROVED BY:</p> <p>_____ CITY ENGINEER</p> <p>REG. C.E. NO. _____</p> <p>DATE _____</p>
---	------------------------------	---

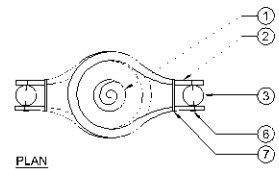
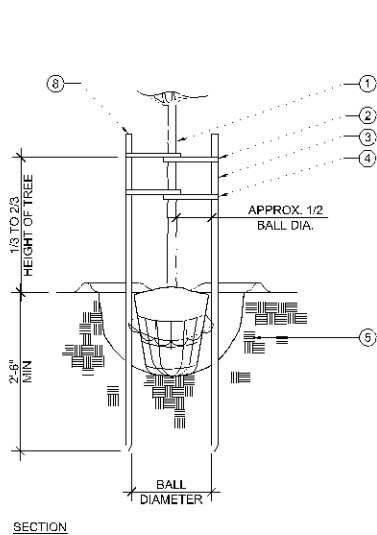

**LEGEND**

- 1. TREE TRUNK
- 2. CUT SEMI-RIGID GARDEN HOSE, UPON INSTALLATION.
- 3. 2" DIAMETER LODGEPOLE TREE STAKE.
- 4. ONLY USE SECOND TIE IF TREE SIZE IS 2 1/2" BOX OR LARGER OR AS REQUIRED.
- 5. EXISTING SOIL.
- 6. 1" GALVANIZED ROOFING NAIL.
- 7. PLASTIC ZIP TIE.
- 8. CUT TOP OF STAKE AS REQUIRED TO CLEAR LOWEST BRANCH BY 6".

**NOTES**

TREE STAKES FOR ALL STREET TREES SHALL BE PARALLEL TO STREET.

**4 TREE STAKING**

NO.	REVISED	BY	APP

DATE: AUGUST 24, 2008  
SCALE: NOT TO SCALE

**CITY OF ALAMEDA**  
CALIFORNIA  
ENGINEERING DEPARTMENT

**Tree Planting Details**

APPROVED BY: \_\_\_\_\_  
CITY ENGINEER  
REG. C.E. NO. \_\_\_\_\_  
DATE \_\_\_\_\_

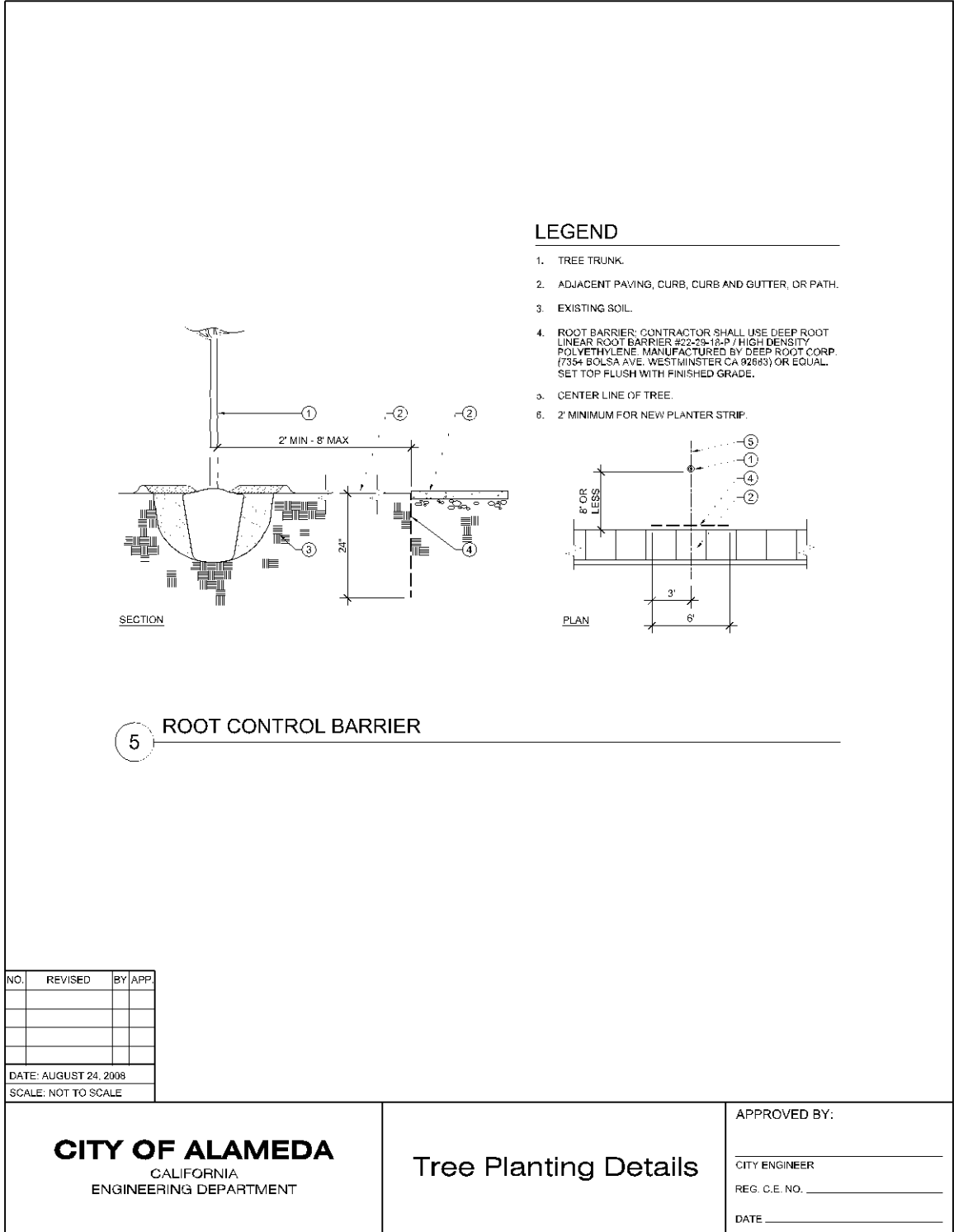

**LEGEND**

- 1. TREE TRUNK.
- 2. ADJACENT PAVING, CURB, CURB AND GUTTER, OR PATH.
- 3. EXISTING SOIL.
- 4. ROOT BARRIER: CONTRACTOR SHALL USE DEEP ROOT LINEAR ROOT BARRIER #22-29-18-P / HIGH DENSITY POLYETHYLENE MANUFACTURED BY DEEP ROOT CORP. (7354 BOLSA AVE. WESTMINSTER CA 92683) OR EQUAL. SET TOP FLUSH WITH FINISHED GRADE.
- 5. CENTER LINE OF TREE.
- 6. 2' MINIMUM FOR NEW PLANTER STRIP.

**5 ROOT CONTROL BARRIER**

NO.	REVISED	BY	APP
DATE: AUGUST 24, 2008			
SCALE: NOT TO SCALE			

**CITY OF ALAMEDA**  
 CALIFORNIA  
 ENGINEERING DEPARTMENT

**Tree Planting Details**

APPROVED BY: \_\_\_\_\_  
 CITY ENGINEER  
 REG. C.E. NO. \_\_\_\_\_  
 DATE \_\_\_\_\_

**APPENDIX 2 / REQUIRED DISTANCES BETWEEN CITY  
INFRASTRUCTURE AND TREES**

## APPENDIX 3 / PROTECTION OF IMPORTANT NESTING HABITAT

Alameda’s trees provide nesting habitat for birds of conservation concern, specifically raptors, herons, and egrets. During nesting season, tree actions should be avoided on or near trees containing active nests of these birds. Disturbing active nests is prohibited under California Fish and Game and U.S. Fish and Wildlife regulations. This Appendix applies to routine tree maintenance and do not applies to trees that are infected with a rapidly spreading pathogen or an imminent threat to public safety.

### Definitions

1. An active nest is a nest that is in use in the current nesting season. Nests from previous nesting seasons that are not in use this nesting season are not active nests.
2. Nesting season is March 1 through September 1.
3. Tree actions are tree-related activities that include branch pruning, sidewalk removal for root shaving, tree removal that uses loud machinery such as chainsaws, pavement saws, chippers, or heavy equipment.

### Guidelines

The following guidelines ensure protection of nesting habitat:

1. Active nests of the following species should not be disturbed:

- Cooper’s Hawk\*
- Sharp Shinned Hawk
- Red Tailed Hawk\*
- Red Shouldered Hawk\*
- White Tailed Kite\*
- American Kestrel
- Merlin
- Great Horned Owl\*
- Western Screech Owl\*
- Barn Owl\*
- Great Blue Heron\*
- Green Heron
- Black Crowned Night Heron
- Great Egret\*
- Snowy Egret\*
- Σ Cattle Egret

\* Active nests of this species were found in Alameda during three nest surveys 2007—2009.

2. To avoid disturbing active nests, tree actions should not be taken on trees containing an active nest or within 200 feet of a tree containing an active nest.

### Identification of Active Nests

The City will work with the community to identify trees containing active nests and will schedule tree actions to avoid disturbing active nests.

Trees containing active nests will be tagged at the beginning of the nesting season. Tags will be removed at the end of the nesting season. City crews and contractors will avoid performing tree actions on trees containing tags or on trees within 200 feet of a tagged tree.

To simplify tagging, areas containing active nests year-after-year should be designated as nest protection zones. Tree actions will not be scheduled within 200 feet of a nest protection zone during nesting season. Trees containing active nests within a nest protection zone will not be tagged.



## APPENDIX 4 / CITY OF ALAMEDA - SPECIAL PLANTING ZONE MAP

- Species American Elm, London Plane, Scarlet Oak, Southern Red Oak and Shumard Oak can be planted in less than 5' planter strip but not less than 3'. If located within marked area.

## **GLOSSARY**

When the following words and phrases are used in this MSTP, they shall have the following meanings unless a different meaning is clearly required by the context:

**Associated Vegetation** shall mean native or non-native shrubs and ground covers within city parks, rights-of-ways, and open spaces.

**City** shall mean the government of Alameda.

**Arborist** shall mean the contracted or City employee who is a current certified arborist by the International Society of Arboriculture and is responsible for administering and enforcing the provisions of this chapter.

**High Risk Tree** shall mean any public tree rated as such by the City according to the tree high risk evaluation standards established by the International Society of Arboriculture.

**Maintain or maintenance** shall mean the entire care of trees within City rights-of-ways and open spaces, as well as the preparation of ground, fertilizing, mulching, planting, disease and insect control, trimming, pruning, staking, root control, watering, leaf litter, weed removal, and removal of dead and dying trees.

Master Street Tree Plan shall mean a document adopted by council that presents street tree inventories, maintenance recommendations, recommended street tree lists, a master design plan for street tree plantings, and urban forestry program goals.

**Street Trees** shall mean all trees and woody plants within public rights-of-ways.

**Planting** shall mean to install public trees permanently in the ground.

**Planting Strip** shall mean the area available for planting including tree pits between the street curbs, the edge of the traveled portion of roadway, and the property line.

**Property Owner** shall mean the person owning such property as shown by the records of the Assessor's Office of Alameda County, California.

**Pruning** shall mean cutting or removing any part of the branching structure of a plant in either the crown, trunk, and/or root areas.

**Removal** shall mean removal of a tree within City rights-of-ways and open spaces.

**Street Tree Standards and Specifications Manual** shall mean a document adopted by council that presents required standards and specifications for public tree planting, maintenance, and removal. Currently, such a document does not exist. If funding is available this may be available in the future.

## **BIBLIOGRAPHY**

American National Standards Institute. "Tree, Shrub, and Other Woody Plant Maintenance – Standard Practices (pruning)." ANSI A300 (Part 1) –Pruning.

American National Standards Institute. "American Standard for Nursery Stock." ANSI Z60.1.

American National Standards Institute. "Pruning, Repairing, Maintaining, and Removing Trees, and Cutting Brush – Safety Requirements." ANSI Z133.1.

Bratton, N.J & K.L.Wolf. "Trees and Roadside Safety in U.S. Urban Settings, Paper 05-0946." In "Proceedings of the 84th Annual Meeting of the Transportation Research Board (January 9-13, 2005)." Transportation Research Board of the National Academies of Science. Washington, DC.

Burden, D. 2006. Urban Street Trees. 22 Benefits. Specific Applications. [online] Glattig Jackson and Walkable Communities Inc. Available from: [www.ufe.org/files/pubs/22BenefitsOfUrbanStreetTrees.pdf](http://www.ufe.org/files/pubs/22BenefitsOfUrbanStreetTrees.pdf) [cited June 2008]

Centre for Urban Forest Research. 2007. Why Shade Streets? The unexpected benefit. Davis: USDA Forest Service (Published 2007). Available from: [http://www.fs.fed.us/psw/programs/cufr/products/cufr\\_673\\_WhyShadeStreets\\_10-06.pdf](http://www.fs.fed.us/psw/programs/cufr/products/cufr_673_WhyShadeStreets_10-06.pdf) [cited June 2008]

City and County of San Francisco. Street Tree Planting Permitting Process. 2007: San Francisco, Department of Public Works. Available from: [www.sfgov.org/site/sfdpw\\_index.asp?id=33090](http://www.sfgov.org/site/sfdpw_index.asp?id=33090) [cited June 2008]

City of Davis. 2002. Community Forest Management Plan. Available from: <http://cityofdavis.org/pgs/trees/pdfs/CFMP-Final-Sept2002-toc.pdf> [cited June 2008].

City of Portland. 1995. "Portland's Urban Forestry Management Plan, public review draft." Portland Parks and Recreation and the Urban Forestry Management Plan Technical Advisory Committee. Portland, OR.

Clark, J. R., N. P. Matheny, G. Cross & V. Wake. 1997. A Model of Urban Forest Sustainability. *Journal of Arboriculture*, 23 (1), 17-30.

Council of Tree and Landscape Appraisers. 2000. "Guide for Plant Appraisal." 9th Edition. 143pp.

Dwyer, John F., Gregory E. McPherson, Herbert W. Schroeder, and Rowan A. Rowntree. 1992. Assessing the Benefits and Costs of the Urban Forest. *Journal of Arboriculture* 18(5).

Gilman, Edward & Sharon Lilly. 2002. Best Management Practices: Tree Pruning. International Society of Arboriculture. Champaign, IL. 35p.

Keating, Janice. 2002. Trees: The Oldest New Thing in Stormwater Treatment Stormwater. Vol. 3 (2).

McPherson, G., S. Maco, J. Simpson, P. Peper, Q. Xiao, AM. VanDerZanden, N. Bell. 2002. Western Community Tree Guide: Benefits, Costs and Strategy Planning.

Miller, R.W. 1997. *Urban Forestry: Planning and Managing Urban Green Spaces*. Prentice Hall. Upper Saddle River, NJ. 188p.

Moll, G. 1989. Improving the health of the urban forest. In Moll, G. and S. Ebenreck (eds.). *Shading Our Cities*, pp. 119-130. *A Resources Guide for Urban and Community Forests*. Island Press. Washington.

Nowak, David J. 2004. *The Effects of Urban Trees on Air Quality*. USDA Forest Service, Syracuse, NY. Available from: <http://www.fs.fed.us/ne/syracuse/TREE%20Air%20Qual.pdf>. [Cited June 2008].

Richards, N.A. 1983. Diversity and stability in street tree populations. *Urban Ecology* 7: 159-171.

Ulrich, Roger S. and Robert F. Simons. 1986. *Recovery from Stress During Exposure to Everyday Outdoor Environments*. In *The Costs of Not Knowing*. Edited by Wineman et. al.

Wolf, K. 1998. *Enterprising landscapes: Business districts and the urban forest*. In C. Kollin, *Engineering Green: Proceedings of the 11th National Urban Forest Conference*. Washington, DC: American Forests.

Wolf, K. 1998. *Trees in Business Districts: Positive Effects on Consumer Behavior! - Fact Sheet 5*. Available from: <http://www.cfr.washington.edu/research.envmind/consumer.html> [Cited June 2008].

Wolf, K. 2003. *Youth and Mental Health: Work Projects in Urban Green Space*. In C. Kollin (ed.), *Engineering Green: Proceedings of the 11th National Urban Forest Conference*. Washington, DC: American Forests.

Wolf, K. 2005a. *Business District Streetscapes, Trees and Consumer Response*. *Journal of Forestry*, 103 (8) 396-400.

Wolf, K. 2005b. *Civic Nature: Valuation: Assessments of Human Functioning and Well-Being in Cities*. In: *Forging Solutions: Applying Ecological Economics to Current Problems*, Proceedings of the 3rd Biennial Conference of the U.S. Society for Ecological Economics (July 20-23, 2005). Tacoma, WA: Earth Economics.

#### **WEB SITES:**

International Society of Arboriculture:  
<http://www.isa-arbor.com/home.aspx>

Center for Urban Forest Research, Pacific Southwest Research Station, USDA Forest Service:  
<http://cufr.ucdavis.edu/>

Human – Environment Research Laboratory, University of Illinois at Urbana Champaign:  
<http://www.herl.uiuc.edu/>

National Arbor Day Foundation:  
<http://www.arborday.org/>

Urban Forestry South. USDA Forest Service, Western Region: <http://www.urbanforestrywest.usda.gov/>

## i. ALAMEDA STREET TREE MATRIX

Tree Species	Common Name	Foliage		Flower/Fruit				Shape	Growth Rate Per Year (once established)	Height at Maturity (feet)	Spread at Maturity (feet)	Trunk Diameter at Breast Height at Maturity (inches)	Longevity (years)
		Deciduous/Evergreen	Fall Color	Flower Color	Flower Period	Fruit	Fruiting Period						
<i>Acer buergerianum</i>	Trident Maple	D	Red or orange	Yellow	Spring	Brown winged seed, 0.5-1.5"	Summer	Rounded, sprcading with a low canopy	24-36"	25	25	20	50-100
<i>Acer campestre</i> 'Queen Elizabeth'*	Hedge Maple	D	Gold	Inconspicuous	Spring	Brown winged seed, 0.5-1.5"	Summer or Fall	Upright	12-36"	35	35	25	50-100
<i>Acer x freemanii</i> 'Autumn Blaze'	Autumn Blaze Hybrid Maple	D	Red	Inconspicuous	Spring	Brown winged seed, 1.5-3"	Fall	Conical or oval, erect of spreading with a high canopy	36"	50	40	30	50-100
<i>Acer nigrum</i> 'Green Column'	Black Maple	D	Gold	Inconspicuous	Spring	Brown winged seed, 0.5-1.5"	Fall	Oval or rounded	24"	65	50	25	50-100
<i>Acer palmatum</i> *	Japanese Maple	D	Red, gold, orange, bronze, purple or multicolor	Inconspicuous	Spring	Brown winged seed, 0.5-1.5"	Summer	Rounded, umbrella or vase	12-24"	25	25	15	50-100
<i>Acer paxii</i> *	Evergreen Maple	E	N/A	Inconspicuous	Spring	Brown winged seed, 0.5-1.5"	Summer	Rounded, erect or spreading with a low canopy	12"	35	35	20	50-100
<i>Acer rubrum</i> 'Armstrang'*	Scarlet Maple	D	Yellow or red	Red	Spring	Brown winged seed, 1.5-3"	Summer	Columnar, erect	36"	45	15	25	50-100
<i>Acer rubrum</i> 'Bowhall'*	Bowhall Maple	D	Red, gold or orange	Red	Spring	Red winged seed, 1.5-3"	Summer	Upright, narrow	36"	40	15	25	50-100
<i>Acer rubrum</i> 'Brandywine'	Brandywine Maple	D	Deep red	Red	Spring	Seedless	N/A	Oval	36"	40	30	25	50-100
<i>Acer rubrum</i> 'Frank Jr.'*	Redpointe Maple	D	Red	Red	Spring	Brown winged seed, 1.5-3"	Summer	Broadly pyramidal	36"	45	30	25	50-100
<i>Acer rubrum</i> 'October Glory'	October Glory Maple	D	Deep red	Red	Spring	Red winged seed, 1.5-3"	Summer	Oval or rounded	36"	40	35	25	50-100
<i>Acer rubrum</i> 'Somerset**	Somerset Maple	D	Red	Red	Spring	Seedless	N/A	Oval or rounded	36"	45	35	25	50-100
<i>Acer rubrum</i> 'Sun Valley'*	Sun Valley Maple	D	Red	Red	Spring	Seedless	N/A	Oval, densely branched	36"	40	35	25	50-100
<i>Acer saccharum</i> 'Autumn Splendor'* <i>Acer saccharum</i> 'Bonfire' <i>Acer saccharum</i> 'Commemoration' <i>Acer saccharum</i> 'Crescendo'* <i>Acer saccharum</i> 'Fall Elzeta'*	Sugar Maple	D	Orange or yellow	Inconspicuous	Spring	Brown winged seed, 1.5-3"	Summer	Oval or rounded, erect or spreading	8-18"	65	40	30	>100
<i>Aesculus carnea</i> 'Briotti'	Red Horsechestnut	D	No change in leaf color	Showy, fragrant, red or rose	Spring	Brown capsule, 0.5-1.5"	Summer or Fall	Rounded or Umbrella, erect or spreading with a low canopy	12-18"	35	30	20	50-100
<i>Aesculus hippocastanum</i> 'Baumannii'	European Horsechestnut	D	Gold	White	Spring	Seedless	N/A	Oval or rounded	12-24"	65	40	25	50-100

\* trees to be considered on an experimental basis, as they have yet to be proven as successful street trees in Alameda (see discussion in sec. 3.2)

\*\* minimum planter width may be less if tree is located within area marked in Appendix 4



Microsite Conditions										Root Zone Mgt.		Nursery Status			Litter Issue	Pests & Diseases	Comments
Tolerates Full Sun	Tolerates Shade	Requires Good Drainage	Tolerates Poor Drainage	Tolerates Moist Soil	Drought Tolerant	Tolerates Sprinklers	Seaside Tolerance	Tolerates Alkaline Soil	Minimum Planter Width (feet)	Harbscape Damage Potential	Nursery Availability	Nursery Origin	Stock Type				
✓	✓			✓			✓	✓	3	Moderate	Good	California	Container		Susceptible to aphids, root rot and verticillium wilt.	A good Japanese Maple substitute. Does not get good fall color in Alameda.	
✓	✓	✓			✓	✓		✓	3	Low	Poor	Oregon	B&B and bareroot		Susceptible to verticillium wilt and tar spot.	Suitable for use in parking lot islands and sidewalk tree pits.	
✓	✓	✓		✓		✓			4	Moderate	Good	California	Container		Susceptible to aphids, beetle borers and scales, oak root rot, root rot, sooty mold and verticillium wilt.	A fast growing hybrid of Red and Silver maple. Fall color in Alameda has been variable. Develops chlorosis in alkaline soils.	
✓	✓	✓			✓	✓			3	Moderate	Good	Oregon	Container		Susceptible to anthracnose, oak root rot, phytophthora, powdery mildew, root rot and verticillium wilt.	Reputed to be one of the toughest maples for street tree use. Tolerant of severe heat and drought once established.	
	✓	✓		✓		✓	✓		3	Low	Good	California and Oregon	B&B and container		Resistant to oak root fungus. Susceptible to root rot, verticillium wilt and sun scorch.	Use as understory with larger trees. Green-leaf varieties can tolerate more sun.	
	✓			✓			✓	✓	3	Low	Poor				Susceptible to aphids, root rot and verticillium wilt.		
✓	✓		✓	✓	✓	✓	✓		3	Moderate	Good	California and Oregon	Bareroot and container		Susceptible to beetle borers and scales, oak root rot, phytophthora, root rot and verticillium wilt.	Not to be planted under high voltage lines.	
✓	✓		✓	✓	✓	✓	✓		3	Moderate	Good	California and Oregon	Bareroot and container		Susceptible to beetle borers and scales, oak root rot, phytophthora, root rot and verticillium wilt.	Not to be planted under high voltage lines.	
✓	✓		✓	✓	✓	✓	✓		3	Moderate	Good	California and Oregon	Bareroot and container		Susceptible to beetle borers and scales, oak root rot, phytophthora, root rot and verticillium wilt.	Very good fall color and a possible <i>Liquidambar</i> substitute. Colors ten day later than most <i>A. rubrum</i> cultivars.	
✓	✓		✓	✓	✓	✓	✓		3	Moderate	Good	California and Oregon	Bareroot and container		Susceptible to beetle borers and scales, oak root rot, phytophthora, root rot and verticillium wilt.	Very good fall color and a possible <i>Liquidambar</i> substitute. The last of the <i>A. rubrum</i> cultivars to color in the fall.	
✓	✓	✓		✓	✓	✓	✓		3	Moderate	Good	California and Oregon	Bareroot and container		Susceptible to beetle borers and scales, oak root rot, phytophthora, root rot and verticillium wilt.		
✓	✓	✓		✓	✓	✓	✓		3	Moderate	Good	California and Oregon	Bareroot and container		Susceptible to beetle borers and scales, oak root rot, phytophthora, root rot and verticillium wilt.		
✓	✓		✓				✓	✓	3	Moderate	Good	Oregon	Bareroot		Susceptible to beetle borers and scales, anthracnose, oak root rot, powdery mildew, root rot and verticillium wilt.		
✓	✓		✓	✓		✓	✓	✓	3	Moderate	Good	California and Oregon	Container	Flowers, dry fruit, leaves	Susceptible to beetle borers, chlorosis, powdery mildew and rust.	Horizontal branching required pruning in early years.	
✓		✓		✓			✓	✓	4	Moderate	Poor			Flowers, leaves	Susceptible to white-marked tussock moth and japanese beetle, leaf blotch, scorch, powdery mildew and leaf spot.		

Tree Species	Common Name	Foliage		Flower/Fruit				Shape	Growth Rate Per Year (once established)	Height at Maturity (feet)	Spread at Maturity (feet)	Trunk Diameter at Breast Height at Maturity (inches)	Longevity (years)
		Deciduous/Evergreen	Fall Color	Flower Color	Flower Period	Fruit	Fruiting Period						
<i>Alsophila australis</i> *	Australian Tree Fern	E	N/A	N/A	N/A	N/A	N/A	Rounded or vase, erect or spreading with a low canopy	35"	25	25	15	<50
<i>Angophora costata</i> *	Gum Myrtle	E	N/A	Showy, white	Summer	Brown capsule, 0.25-0.5"	Fall	Conical or rounded, erect or spreading with high canopy	24"	50	40	25	50-100
<i>Betula nigra</i> 'Heritage'	Heritage River Birch	D	Gold	Inconspicuous	Spring	Catkins	Spring	Pyramidal	24-36"	45	30	30	50-100
<i>Carpinus betulus</i> 'Fastigata'	European Hornbeam	D	Red, gold or multicolor	Inconspicuous	Spring	Brown winged seed, 0.25-0.5"	Winter or Summer	Columnar or conical, erect with low canopy	12-24"	35	40	15	50-100
<i>Carpinus betulus</i> 'Frans Fontaine'	European Hornbeam	D	Red, gold or multicolor	Inconspicuous	Spring	Brown winged seed, 0.25-0.5"	Winter or Summer	Columnar or conical, erect with low canopy	12-24"	35	15	15	50-100
<i>Carpinus caroliniana</i> *	American Hornbeam	D	Red, gold, orange or multicolor	Inconspicuous	Spring	Small winged seed, 0.25-0.5"	Winter or Summer	Rounded or umbrella, erect with a low canopy	12-24"	35	30	20	50-100
<i>Cercis canadensis</i> *	Eastern Redbud	D	Gold	Pink	Spring	Brown pods, 1.5-3"	Summer	Rounded or Umbrella, erect or spreading with a low canopy	36"	25	25	10	<50
<i>Chionanthus retusus</i> *	Chinese Fringe Tree	D	Gold	White	Summer	Purple drupe, 0.5-1.5"	Fall or Winter	Rounded or umbrella, spreading	24"	20	15	15	<50
<i>Corylus colurna</i> *	Turkish Hazel	D	Yellow	Green or yellow	Winter	Small brown nut enclosed in leafy bracts, edible, 0.25-0.5"	Fall	Oval or umbrella, erect or spreading and covers an extensive area	12-24"	60	35	25	50-100
<i>Corymbia ficifolia</i>	Red Flowering Gum	E	N/A	Showy, orange, pink, red or rose	Spring, Summer, Fall or Winter	Brown capsule, 0.5-1.5"	Spring, Summer or Fall	Rounded, erect or spreading with a low canopy	24"	35	30	30	50-100
<i>Crataegus</i> x 'Vaughn'	Vaughn Hawthorn	D	Red or orange	White	Spring	Red pome, 0.25", persisting through winter	Fall	Oval, erect or spreading with a low canopy	24-36"	25	20	15	50-100
<i>Cupressus sempervirens</i> *	Italian Cypress	E	N/A	Inconspicuous	Spring	Brown cone, 0.5-1.5"	Fall	Columnar, erect	36"	50	30	25	50-150
<i>Fagus sylvatica</i>	European Beech	D	Bronze	Inconspicuous	Spring	Brown nut in spiny husk, 0.5-1.5", edible	Fall	Broadly pyramidal to broadly oval	24"	60	50	35	50-100
<i>Ginkgo biloba</i> 'Fairmont'	Fairmont Maidenhair Tree	D	Gold	Inconspicuous	Winter	Fruitless	N/A	Pyramidal with dominant leader	12-24"	50	25	40	>100
<i>Ginkgo biloba</i> 'Golden Colonnade'	Golden Colonnade Maidenhair Tree	D	Gold	Inconspicuous	Winter	Fruitless	N/A	Narrow, conical	12-18"	45	25	25	>100
<i>Ginkgo biloba</i> 'Magyar'	Magyar Maidenhair Tree	D	Gold	Inconspicuous	Winter	Fruitless	N/A	Narrow, pyramidal	12-18"	50	25	25	>100

\* trees to be considered on an experimental basis, as they have yet to be proven as successful street trees in Alameda (see discussion in sec. 3.2)

\*\* minimum planter width may be less if tree is located within area marked in Appendix 4

Microsite Conditions										Root Zone Mgt.		Nursery Status			Litter Issue	Pests & Diseases	Comments
Tolerates Full Sun	Tolerates Shade	Requires Good Drainage	Tolerates Poor Drainage	Tolerates Moist Soil	Drought Tolerant	Tolerates Sprinklers	Seaside Tolerance	Tolerates Alkaline Soil	Minimum Planter Width (feet)	Hardscape Damage Potential	Nursery Availability	Nursery Origin	Stock Type				
✓	✓	✓		✓				✓	✓	2	Low	Poor			Leaves	Susceptible to spider mites and root rot.	Grows best in partial shade. Also known as <i>Cyathea australis</i> , <i>C. cooperi</i> , <i>Aisophila cooperi</i> and <i>Sphaeropteris cooperi</i> .
✓			✓	✓	✓			✓	✓	3	Moderate	Poor			Exfoliating bark	Resistant to oak root fungus.	Tolerates smog.
✓	✓	✓		✓		✓				3	Low	Good	California	Container		Susceptible to leaf miner, leaf spot and scorch.	Heritage Birch requires an acid to neutral soil, and will turn chlorotic in alkaline soil. Prefers moist soil. Reportedly resistant to Bronze Birch Borer.
✓	✓			✓	✓	✓	✓			3	Low	Good	California and Oregon	Bareroot and container	Dry fruit	Resistant to verticillium wilt. Susceptible to aphids, scales, oak root rot and root rot.	Needs very little pruning to maintain good form. 2" leaves produce a handsome texture, and the winter twig pattern is attractive.
✓	✓			✓	✓	✓	✓			3	Low	Good	California and Oregon	Bareroot and container	Dry fruit	Resistant to verticillium wilt. Susceptible to aphids, scales, oak root rot and root rot.	Needs very little pruning to maintain good form. 2" leaves produce a handsome texture, and the winter twig pattern is attractive. 'Frans Fontaine' is more slender than 'Fastigata'.
✓	✓	✓		✓				✓		3	Low	Good	California and Oregon	Bareroot and container	Dry fruit	Resistant to verticillium wilt. Susceptible to oak root rot and root rot.	Often multi-stemmed. Requires a moderate amount of water.
✓	✓			✓				✓	✓	3	Low	Good	California and Oregon	Container	Dry fruit	Susceptible to caterpillars and scales, anthracnose, crown rot, oak root rot, phytophthora, root rot and verticillium wilt.	Showy pink flowers bloom best in full sun, and with moderate moisture. It may require light top pruning (not topping) of vigorous top shoots to maintain its height below 25'.
✓	✓			✓				✓	✓	3	Low	Good	California and Oregon	Container	Wet fruit		Its fragrant spring flowering is quite impressive, and is attractive in fall, when the reddish berries are seen amongst the yellow fall foliage. This is a very clean looking tree. It is easily maintained below 25' in height.
✓	✓	✓		✓				✓		3	Moderate	Good	Oregon	Bareroot	Dry fruit	Susceptible to chlorosis, powdery mildew and sooty mold.	
✓	✓	✓		✓	✓	✓	✓	✓	✓	3	Moderate	Good	California	Container	Dry fruit	Resistant to Texas root rot and verticillium. Susceptible to beetle borers and thrips, oak root rot, phytophthora and root rot.	Red flowering gum is very desirable as a flowering accent tree, with its profusion of bright flower clusters in late summer, and sporadically throughout the year. Has fragrant leaves.
✓				✓	✓				✓	2	Low	Poor			Wet fruit	Resistant to verticillium. Susceptible to aphids, beetle borers, scales and spider mites, fire blight, oak root rot, powdery mildew, root rot, rust and sooty mold.	Branches with thorns. The foliage is reddish purple when unfolding, changing to lustrous dark green at maturity and turning to orange, scarlet and purple in autumn. The white flower clusters in early June are effective for 7 to 10 days. The fruit persists all winter.
✓	✓		✓	✓	✓	✓		✓		3	Moderate	Good	California	Container	Dry fruit	Resistant to Texas root rot. Susceptible to spider mites, gummosis, phytophthora and root rot.	
✓			✓	✓	✓	✓	✓	✓		4	Moderate	Good	Oregon	Container and B&B	Dry fruit	Resistant to verticillium. Susceptible to aphids and spider mites, canker, oak root rot, phytophthora, root rot and sooty mold.	Limit plantings to wide medians.
✓	✓	✓		✓		✓	✓	✓		3	Moderate	Good	California and Oregon	Bareroot and container		Resistant to oak root fungus. Susceptible to anthracnose.	Ginkgo is a smog tolerant and hardy tree. Not to be planted in East end of city due to large existing Ginkgo population. 'Fairmont' is faster growing than other Ginkgo varieties.
✓	✓		✓	✓		✓	✓	✓		4	Moderate	Good	California and Oregon	Bareroot and container		Resistant to oak root fungus. Susceptible to anthracnose.	Ginkgo is a smog tolerant and hardy tree. Not to be planted in East end of city due to large existing Ginkgo population.
✓	✓		✓	✓		✓	✓	✓		4	Moderate	Good	California and Oregon	Bareroot and container		Resistant to oak root fungus. Susceptible to anthracnose.	Ginkgo is a smog tolerant and hardy tree. Not to be planted in East end of city due to large existing Ginkgo population.

Tree Species	Common Name	Foliage		Flower/Fruit				Shape	Growth Rate Per Year (once established)	Height at Maturity (feet)	Spread at Maturity (feet)	Trunk Diameter at Breast Height at Maturity (inches)	Longevity (years)
		Deciduous/Evergreen	Fall Color	Flower Color	Flower Period	Fruit	Fruiting Period						
<i>Ginkgo biloba</i> 'Princeton Sentry'*	Princeton Sentry Maidenhair Tree	D	Gold	Inconspicuous	Winter	Fruitless	N/A	Narrow, columnar, erect	12-18"	50	20	25	>100
<i>Ginkgo biloba</i> 'Saratoga'	Saratoga Maidenhair Tree	D	Gold	Inconspicuous	Winter	Fruitless	N/A	Conical or oval, erect or spreading and covers an extensive area	12-18"	50	30	25	>100
<i>Gymnocladus dioica</i> 'Espresso'**	Kentucky Coffee Tree	D	Gold	Inconspicuous	Summer	Fruitless	N/A	Oval to vase shaped with upright arching branches	24-36"	50	35	30	50-100
<i>Jacaranda mimosifolia</i>	Jacaranda	E	N/A	Showy blue or lavender	Spring, Summer or Fall	Brown capsule, 1.5-3"	Summer or Fall	Oval, rounded, umbrella or vase, spreading with a high canopy	24"	40	60	25	<50-100
<i>Koelreuteria bipinnata</i>	Chinese Flame Tree	D	Bronze or gold	Yellow	Summer or Fall	Prolific red-pink capsules, 1.5- 3"	Fall	Rounded, umbrella or vase	18-24"	35	35	20	50-100
<i>Lagerstromia</i> x 'Natchez' <i>Lagerstromia</i> x 'Tuscarora'	Hybrid Crape Myrtle	D	Red, gold, orange or multicolor	'Natchez' has white flowers. 'Tuscarora' has pink flowers.	Summer	Brown capsule, 0.25-0.5"	Fall	Oval, rounded, umbrella or vase, erect or spreading with a low canopy	12-24"	25	15	15	50-100
<i>Laurus nobilis</i> 'Saratoga'	Sweet Bay	E	N/A	Yellow-green	Spring	Black berry, 0.5"	Summer	Conical or oval	12-24"	35	20	25	50-150
<i>Livistona australis</i> **	Australia Palm	E	N/A	Cream	Spring	Black or brown drupe, 0.5-1.5"	Summer or Fall	Fan palm, erect with a high canopy	12"	50	30	20	50-100
<i>Lophostemon confertus</i>	Brisbane Box	E	N/A	Showy, white	Spring	Brown capsule, 0.25-0.5"	Summer	Oval or rounded, erect or spreading and covers and extensive area	24-36"	50	30	25	50-100
<i>Magnolia grandiflora</i> 'Russet' <i>Magnolia grandiflora</i> 'St. Mary'	Southern Magnolia	E	N/A	Showy, fragrant, white	Spring, Summer or Fall	Purple or red follicle, 3" long	Summer or Fall	Oval, rounded or umbrella, erect or spreading	24"	65	60	50	>100
<i>Metrosideros excelsus</i>	New Zealand Christmas Tree	E	N/A	Showy, red	Spring or Summer	Brown capsule, 0.25-0.5"	Summer or Fall	Oval or rounded, erect or spreading with a low canopy	18-24"	35	35	30	50-100
<i>Nyssa sylvatica</i> 'Red Rage'* <i>Nyssa sylvatica</i> 'Forum'*	Sour Gum	D	Red, orange or multicolor	Inconspicuous	Spring	Black drupe, 0.5- 1.5"	Fall or Winter	Conical or oval, erect or spreading with a high canopy	12-18"	65	25	30	>100
<i>Persea americana</i> *	Avocado	E	N/A	Showy green	Spring	Medium-large fruits, edible	Fall	Rounded, spreading	12-36"	50	40	15	50-100
<i>Persea barbonia</i> *	Redbay	E	N/A	Inconspicuous	Spring	Persistent, blue, 0.25-0.5"	Fall	Rounded, spreading	12-36"	50	50	20	50-100
<i>Persea indica</i> *	Avocado	E	N/A	Inconspicuous	Spring	Black, 0.5-1"	Fall	Rounded, spreading	12-36"	30	40	15	50-100

\* trees to be considered on an experimental basis, as they have yet to be proven as successful street trees in Alameda (see discussion in sec. 3.2)

\*\* minimum planter width may be less if tree is located within area marked in Appendix 4

Microsite Conditions											Root Zone Mgt.		Nursery Status			Litter Issue	Pests & Diseases	Comments
Tolerates Full Sun	Tolerates Shade	Requires Good Drainage	Tolerates Poor Drainage	Tolerates Moist Soil	Drought Tolerant	Tolerates Sprinklers	Seaside Tolerance	Tolerates Alkaline Soil	Minimum Planter Width (feet)	Hardscape Damage Potential	Nursery Availability	Nursery Origin	Stock Type					
✓	✓		✓	✓		✓		✓	4	Moderate	Good	California and Oregon	Bareroot and container		Resistant to oak root fungus. Susceptible to anthracnose.	'Princeton Sentry' has fragrant flowers in Spring. Ginkgo is a smog tolerant and hardy tree. Not to be planted in East end of city due to large existing Ginkgo population.		
✓	✓		✓	✓		✓		✓	4	Moderate	Good	California and Oregon	Bareroot and container		Resistant to oak root fungus. Susceptible to anthracnose.	Ginkgo is a smog tolerant and hardy tree. Not to be planted in East end of city due to large existing Ginkgo population.		
✓	✓		✓	✓	✓	✓		✓	3	Moderate	Good	Oregon	Bareroot		Resistant to oak root fungus.			
✓		✓		✓			✓	✓	3	Low	Good	California	Container	Flower and dry fruit	Resistant to oak root fungus. Susceptible to aphids, phytophthora and root rot.	Well-adapted to Alameda's sandy soils. Place where it will get frequent watering. Neighborhood specific. Reported to have weak branch strength.		
✓	✓	✓		✓	✓	✓		✓	4	Moderate	Good	California	Container	Dry fruit	Susceptible to beetle borers and scales.	Becomes a round-headed tree requiring little pruning at maturity, but needs training when young, as it tends to form multiple leaders.		
✓	✓			✓	✓	✓		✓	3	Low	Good	California	Container	Flowers, dry fruit	Resistant to powdery mildew. Susceptible to aphids and sooty mold.	'Tuscarora' has multiple stems.		
✓	✓	✓		✓	✓	✓		✓	4	Moderate	Good	California	Container	Dry fruit	Susceptible to psyllids and scales, phytophthora and root rot.	Dense canopy of fragrant leaves. Early pruning needed to train a good shape; pruning needed less frequently with age. Requires removal of suckers.		
✓	✓			✓	✓	✓		✓	4	Moderate	Poor			Dry fruit	Resistant to Texas root rot. Susceptible to pigeons.	Fan palm with dark, shiny leaves. Needs moderate watering.		
✓	✓		✓	✓	✓	✓		✓	3	Low	Good	California	Container	Dry fruit	Susceptible to scales, phytophthora and root rot.	Previously known as <i>Tristanis conferta</i> . Drought resistant once established. Smog tolerant. The red peeling bark and foliage are reminiscent of native <i>Arbutus</i> . Use like a small <i>Eucalyptus</i> tree with few structural problems. Extensive fruit drop from mature trees sometimes causes complaints.		
✓	✓			✓	✓		✓	✓	5	High	Good	California	Container	Leaves	Resistant to oak root fungus. Susceptible to aphids, scales and spider mites, root rot and verticillium wilt.	Not to be planted near drain inlets, as leaves may obstruct drainage. Only to be planted in wide planter strips or medians.		
✓	✓	✓		✓	✓	✓		✓	4	Moderate	Good	California	Container	Dry fruit	Susceptible to phytophthora and root rot.	Smog tolerant. Leave low trunk twigs to encourage strong structure. Not to be planted in small planter strips.		
✓	✓		✓	✓	✓	✓		✓	4	Low	Good	Oregon	B&B and container	Dry fruit	Susceptible to fusarium, phytophthora, root rot, rust and verticillium wilt. Also susceptible to lime-induced chlorosis in alkaline soils.	Should use only suggested varieties to ensure good form and color.		
✓	✓	✓		✓		✓		✓	2	Low	Poor			Leaves	Susceptible to phytophthora root rot, mites, scales and leaf spot.	Drainage is a concern with this species. Amending soil with mulch and gypsum may suppress root rot.		
✓	✓	✓		✓	✓	✓		✓	5	Low	Poor			Fruit and leaves	Susceptible to borer, scales and sooty mold.	Redbay is a rugged and adaptable plant suitable to many landscape applications. Unfortunately, the wood is reportedly brittle and subject to wind damage. Pruning to keep lateral branches less than half the diameter of the trunk will increase the tree's longevity and help prevent branches from separating from the trunk.		
✓		✓		✓		✓			2	Low	Poor			Leaves	Susceptible to phytophthora root rot.	Might be a good substitute for Camphor if fruiting can be limited, perhaps by using Guatemalan varieties, and/or limiting selections to varieties with Type A or Type B flowers. Potential for sidewalk damage needs to be assessed. Seems to thrive in Alameda as a yard tree. Does not do well with high water table and winds. Only to be planted inland. Amending soil with mulch and gypsum may suppress root rot.		

Tree Species	Common Name	Foliage		Flower/Fruit									
		Deciduous/Evergreen	Fall Color	Flower Color	Flower Period	Fruit	Fruiting Period	Shape	Growth Rate Per Year (once established)	Height at Maturity (feet)	Spread at Maturity (feet)	Trunk Diameter at Breast Height at Maturity (inches)	Longevity (years)
<i>Phoenix canariensis</i>	Canary Island Palm	E	N/A	Yellow	Spring	Orange or yellow drupe, 0.5-1.5"	Fall	Feather palm, erect and covers an extensive area	12"	65	25	35	50-100
<i>Pistachia chinensis</i> 'Keith Davey'	Chinese Pistache	D	Red, orange, gold or multicolor	Inconspicuous	Spring	Prolific red or blue drupe, 0.5"	Summer or Fall	Oval, rounded or umbrella, erect or spreading with a high canopy	12-18"	65	50	25	>100
<i>Platanus acerifolia</i> 'Bloodgood'**, <i>Platanus acerifolia</i> 'Columbia'**, <i>Platanus acerifolia</i> 'Yarwood'**	London Planetree	D	Bronze or gold	Inconspicuous	Spring or Winter	Brown seed balls, 0.5-1.5"	Summer	Oval, rounded or umbrella, erect or spreading and covers an extensive area	36"	70	50	35	>100
<i>Podocarpus gracilior</i>	Fern Pine	E	N/A	Inconspicuous	Spring	Purple drupe, 0.25-0.5"	Fall	Oval or rounded, erect and covers an extensive area	12-24"	50	35	30	>100
<i>Prunus sargentii</i> 'Columnaris'*	Columnar Sargent Cherry	D	Red, gold or bronze	Showy pink	Spring	Purple, red or black drupe, 0.25-0.5"	Fall, Winter or Summer	Columnar or vase, erect	12-36"	35	20	20	40
<i>Prunus yedoensis</i> *	Yoshino Flowering Cherry	D	Bronze or gold	Showy, fragrant pink or white	Spring or Winter	Black drupe, 0.25-0.5"	Winter or Summer	Oval, rounded or umbrella, erect or spreading with a low canopy	36"	35	30	20	<50-100
<i>Pyrus calleryana</i> 'Aristocrat' <i>Pyrus calleryana</i> 'Chanticleer'	Callery Pear	D	Red, gold, purple or multicolor	Showy, fragrant, white	Spring	Brown pome, 0.25-0.5"	Summer	Oval or rounded, erect or spreading, low or high canopy	24"	35-50	45	20	50-100
<i>Quercus coccinea</i> **	Scarlet Oak	D	Red	Inconspicuous	Spring	Acorns, 0.5-1.5"	Fall or Winter	Oval, rounded or umbrella, erect or spreading and covers an extensive area	24"	60	60	40	>100
<i>Quercus falcata</i> ** **	Southern Red Oak	D	Bronze	Inconspicuous	Spring	Acorns	Fall	Oval or rounded	24"	65	60	40	>100
<i>Quercus palustris</i> *	Pin Oak	D	Bronze, red gold or multicolor	Inconspicuous	Spring	Acorns, 0.5-1.5"	Fall or Winter	Conical, rounded	24"	65	35	30	>100
<i>Quercus shumardii</i> **	Shumard Oak	D	Red, gold, orange or multicolor	Inconspicuous	Spring	Acorns, 0.5-1.5"	Fall	Oval, rounded or umbrella, erect or spreading and covers an extensive area	24-36"	65	45	30	>100
<i>Quercus suber</i>	Cork Oak	E	N/A	Inconspicuous	Spring	Prolific acorns, 0.5-1.5"	Fall or Winter	Oval, rounded or umbrella, erect or spreading and covers an extensive area	24"	70	45	50	>100
<i>Quercus virginiana</i> *	Southern Live Oak	E	N/A	Inconspicuous	Spring	Acorn, 0.5-1.5"	Fall or Winter	Oval, rounded or umbrella, erect or spreading with a high canopy	24-36"	60	60	50	>100

\* trees to be considered on an experimental basis, as they have yet to be proven as successful street trees in Alameda (see discussion in sec. 3.2)

\*\* minimum planter width may be less if tree is located within area marked in Appendix 4

Microsite Conditions										Root Zone Mgt.		Nursery Status			Litter Issue	Pests & Diseases	Comments
Tolerates Full Sun	Tolerates Shade	Requires Good Drainage	Tolerates Poor Drainage	Tolerates Moist Soil	Drought Tolerant	Tolerates Sprinklers	Senside Tolerance	Tolerates Alkaline Soil	Minimum Planter Width (feet)	Hardscape Damage Potential	Nursery Availability	Nursery Origin	Stock Type				
✓		✓		✓	✓	✓	✓	✓	4	Low	Good	California	Container	Dry fruit and leaves	Resistant to Texas root rot. Susceptible to pigeons, <i>Fusarium</i> and root rot.	This is probably the most useful of available palms for street side uses. It should be used in areas broad enough to not only prevent the lateral expansion of the trunk from breaking pavement, but also to prevent the fruit from making a mess on the sidewalk areas.	
✓	✓	✓		✓	✓	✓		✓	3	Low	Good	California and Oregon	Container	Dry fruit	Resistant to oak root fungus. Susceptible to root rot and verticillium wilt.	Requires pruning in the first 2-4 years to prevent clearance problems caused by horizontal branch growth. One of the best fall coloring trees for this climate. Not for use in heavily watered lawns. 'Keith Davey' has a more uniform structure and is easier to maintain than other varieties.	
✓	✓			✓	✓	✓		✓	5	Moderate	Good	California and Oregon	Bareroot and container		'Yarwood' resistant to powdery mildew. 'Bloodgood' resistant to anthracnose. 'Columbia' resistant to both.	Will grow in almost any soil. Needs very little pruning to achieve semi-open habit and good form.	
✓	✓	✓		✓	✓	✓	✓	✓	4	Moderate	Good	California	Container	Dry fruit	Susceptible to black scale.	Produces a round or oval, upright form covered with narrow blue-green foliage and a fairly dense canopy. The excellent branching is easily shaped into well structured crowns. Hardscape damage has been noted in the few mature trees in CA. Can be messy when leaves drop.	
✓		✓		✓		✓			3	Low	Good	Oregon	Container		Susceptible to caterpillars, aphids, borer and scales. Trees in heavy soil sometimes subject to root rot.	This species of cherry is far better adapted to urban tree use than the more commonly used cultivars. It will tolerate poor soil. Branches don't droop, and are susceptible to breakage. First planted in Alameda in 2005.	
✓		✓		✓			✓	✓	3	Low	Good	California and Oregon	Bareroot and container	Flower and dry fruit	Susceptible to caterpillars, canker, crown rot, oak root rot, phytophthora, root rot, rust and verticillium wilt.	On clay soils, plant on slopes or in raised beds.	
✓	✓	✓		✓	✓	✓		✓	3	Moderate	Good	California and Oregon	Bareroot and container	Dry fruit	Fairly resistant to fire blight, oak root fungus and verticillium wilt. Susceptible to whiteflies.	'Aristocrat' only to be planted in business districts of Park St. and Webster. Requires annual pruning at the beginning to establish good structure and prevent splitting later on. Very good fall color.	
✓	✓			✓	✓	✓	✓	✓	4	Moderate	Good	California and Oregon	Bareroot and container	Acorns	Resistant to verticillium wilt. Susceptible to caterpillars and scales.	This is the most colorful of the Eastern Oaks, with a reliable brilliant red color in the fall. Many specimens hold most brown leaves all winter. Possible Liquidambar substitute. Best in deep, rich soil.	
✓		✓		✓	✓	✓			5	Low	Good	Oregon	Bareroot		Susceptible to caterpillars.	Appears to produce reliable red fall color with consistent upright growth habit. Does not appear subject to aphids. Possible alternative to Q. coccinea where a taller and less spreading tree is desired. Possible Liquidambar substitute.	
✓	✓		✓	✓	✓	✓			3	Low	Good	California and Oregon	Bareroot and container	Acorns	Resistant to verticillium wilt. Susceptible to scales, anthracnose, and occasional chlorosis, especially in clay soils.	Some branches hang very low, and may cause clearance problems unless kept pruned. Highly variable growth forms may be problematic. Brown leaves tend to hang on the tree of some specimens in winter. May become chlorotic in alkaline soil.	
✓	✓			✓	✓	✓		✓	5	Moderate	Good	California and Oregon	Bareroot and container	Acorns	Resistant to verticillium wilt. Susceptible to beetle borers, beetle leaves, caterpillars, insect galls, leaf miner and scales.	More easily transplanted than Scarlet Oak. Not as prone to iron deficiency as Pin Oak.	
✓	✓	✓		✓	✓		✓	✓	8	Moderate	Good	California	Container		Resistant to verticillium wilt. Susceptible to phytophthora and root rot.	Does not like having persistently wet roots, therefore, cannot be planted in grass, or near irrigation. Leaf drop in spring may seem abnormal, but is typical pattern for the tree. Bark is the source of commercial cork.	
✓	✓		✓	✓		✓		✓	6	Moderate	Good	California	Container	Acorns	Resistant to verticillium wilt. Susceptible to insect galls, oak root rot, phytophthora and root rot.	Best in deep, rich soil, but widely adapted to a variety of soil types.	

Tree Species	Common Name	Foliage		Flower/Fruit				Shape	Growth Rate Per Year (once established)	Height at Maturity (feet)	Spread at Maturity (feet)	Trunk Diameter at Breast Height at Maturity (inches)	Longevity (years)
		Deciduous/Evergreen	Fall Color	Flower Color	Flower Period	Fruit	Fruiting Period						
<i>Rhus lancea</i> *	African Sumac	E	N/A	Inconspicuous	Summer	Red or yellow drupe, 0.25-0.5"	Fall	Rounded or umbrella, spreading or weeping with a low canopy	24"	25	25	30	50-100
<i>Taxodium distichum</i> *	Bald Cypress	D	Bronze or orange	Inconspicuous	Summer or Fall	Fragrant, Brown cone, 0.5-1.5"	Summer or Fall	Conical, erect or spreading and covers an extensive area	24-36"	65	40	35	50-100
<i>Taxodium mucronatum</i> *	Montezuma Cypress	E	N/A	Inconspicuous	Summer or Fall	Fragrant, Brown cone, 0.5-1.5"	Summer or Fall	Conical, erect or weeping and covers an extensive area	36"	65	50	50	50-100
<i>Tilia tomentosa</i> 'Green Mountain' <i>Tilia tomentosa</i> 'Sterling'	Silver Linden	D	Gold	Showy, fragrant, yellow or white	Summer	Gray capsule, 0.25-0.5"	Fall	Conical, oval or umbrella, erect or spreading with high canopy and extensive area	18-48"	50	40	25	50-100
<i>Tristania laurina</i> 'Elegans'	Swamp Myrtle	E	N/A	Showy, yellow	Spring or Summer	Brown capsule, 0.25-0.5"	Summer or Fall	Oval or rounded, erect or spreading with a low canopy	12"	25	20	15	<50-100
<i>Ulmus americana</i> 'Jefferson' <sup>***</sup> <i>Ulmus americana</i> 'New Harmony' <sup>***</sup> <i>Ulmus americana</i> 'Princeton' <sup>**</sup> <i>Ulmus americana</i> 'Valley Forge' <sup>**</sup>	American Elm cultivars	D	Yellow	Inconspicuous	Spring	Green, wafer-like seedpods, 0.25-0.5"	Spring	Upright or spreading, vase shape	36"	70	60	80	>100
<i>Ulmus</i> 'Frontier'	Frontier Elm	D	Burgundy	Inconspicuous	Spring	Green, wafer-like seedpods, 0.25-0.5"	Spring	Broadly oval	36"	40	30	25	unknown
<i>Ulmus</i> 'Morton' <sup>*</sup>	Accolade Elm	D	Yellow	Inconspicuous	Spring	Green, wafer-like seedpods, 0.25-0.5"	Spring	Upright, vase-shaped with arching limbs	36"	70	60	unknown	unknown
<i>Ulmus</i> 'Morton Glossy' <sup>*</sup>	Triumph Elm	D	Yellow	Inconspicuous	Spring	Green, wafer-like seedpods, 0.25-0.5"	Spring	Upright oval to vase	36"	55	45	unknown	unknown
<i>Ulmus</i> 'Morton Stalwart' <sup>*</sup>	Commendation Elm	D	Yellow	Inconspicuous	Spring	Green, wafer-like seedpods, 0.25-0.5"	Spring	Upright oval	36"	60	50	unknown	unknown
<i>Ulmus</i> 'Patriot' <sup>*</sup>	Patriot Elm	D	Yellow	Inconspicuous	Spring	Green, wafer-like seedpods, 0.25-0.5"	Spring	Stiffly upright, narrow vase shape	36"	50	40	unknown	unknown
<i>Washingtonia robusta</i>	Mexican Fan Palm	E	N/A	Inconspicuous	Summer	Edible black drup, 0.25-0.5"	Fall or Winter	Fan palm, erect and covers an extensive area	18-24"	>65	15	20	50-100

\* trees to be considered on an experimental basis, as they have yet to be proven as successful street trees in Alameda (see discussion in sec. 3.2)

\*\* minimum planter width may be less if tree is located within area marked in Appendix 4



Microsite Conditions										Root Zone Mgt.		Nursery Status			Litter Issue	Pests & Diseases	Comments
Tolerates Full Sun	Tolerates Shade	Requires Good Drainage	Tolerates Poor Drainage	Tolerates Moist Soil	Drought Tolerant	Tolerates Sprinklers	Seaside Tolerance	Tolerates Alkaline Soil	Minimum Planter Width (feet)	Hardscape Damage Potential	Nursery Availability	Nursery Origin	Stock Type				
✓	✓			✓	✓		✓	✓	4	Low	Good	California	Container	Dry fruit	Susceptible to root rot and verticillium wilt.	A dense shade tree, rather graceful with its arching branches and weeping foliage. It is tough and reliable in dry conditions, though it looks best with regular deep watering. It may require regularly scheduled light pruning (but not topping) of vigorous top shoots to maintain its height below 25 feet.	
✓	✓		✓	✓		✓	✓	✓	4	Moderate	Good	Oregon	Bareroot and container	Dry fruit	Resistant to oak root fungus. Susceptible to beetle borers and beetle leaves, phytophthora and root rot.	Plant only in wide medians.	
✓	✓			✓	✓			✓	5	Moderate	Poor			Dry fruit	Susceptible to beetle borers and beetle leaves.	Fairly drought tolerant, but needs ample water when young. Plant only in wide medians.	
✓	✓	✓		✓	✓	✓		✓	3	Low	Good	Oregon	Bareroot and container	Dry fruit	Susceptible to root rot, sooty mold and verticillium wilt.	Light green leaves with silver undersides move in any breeze. Faster growing than most Lindens, with good yellow fall color in Alameda. Unlike other Lindens, does not appear subject to aphids.	
✓	✓			✓				✓	2	Low	Good	California	Container	Dry fruit and flowers	Susceptible to scales.	It is useful where only small planter spaces are available. Easily pruned to any form.	
✓	✓		✓	✓	✓	✓	✓	✓	6	High	Good	Oregon	Bareroot	Dry seeds	Resistant to Dutch elm disease and elm leaf beetle.		
✓	✓			✓		✓		✓	3	Low	Good	California and Oregon	Bareroot and container	Dry seeds	Resistant to Dutch elm disease and elm yellows.	This is a hybrid between <i>U. carpinifolia</i> and <i>U. parvifolia</i> .	
✓	✓			✓	✓	✓	✓	✓	6	Moderate	Good	Oregon	Bareroot and container	Dry seeds	Resistant to elm yellows, elm leaf beetle, elm leaf miner and Dutch elm disease.	This is a hybrid between <i>U. japonica</i> and <i>U. wilsoniana</i> .	
✓	✓			✓		✓		✓	4	Moderate	Good	Oregon	Bareroot	Dry seeds	Resistant to Dutch elm disease.	This is a hybrid between <i>U. wilsoniana</i> , <i>U. japonica</i> and <i>U. pumila</i> .	
✓	✓			✓		✓		✓	5	Moderate	Good	Oregon	Bareroot	Dry seeds	Resistant to Dutch elm disease.	This is a hybrid between <i>U. wilsoniana</i> , <i>U. pumila</i> and <i>U. carpinifolia</i> .	
✓	✓			✓		✓		✓	4	Moderate	Good	Oregon	Bareroot	Dry seeds	Resistant to Dutch elm disease.	This is a hybrid between <i>U. wilsoniana</i> , <i>U. carpinifolia</i> , <i>U. glabra</i> and <i>U. pumila</i> .	
✓	✓	✓		✓	✓	✓	✓	✓	3	Low	Good	California	Container	Dry fruit and leaves	Resistant to Texas root rot. Susceptible to beetle borers and pigeons.	A moderately invasive species. Use for special situations, such as on Burbank Street and to preserve views on Shoreline Drive. Planting at each of these locations should be at the same time to establish uniformity.	

## ii. DEFINITION OF TERMS IN THE TREE MATRIX

### TREE SPECIES

Botanical names (Genus and species) are the Latin nomenclature for a plant, by which it is identified in nurseries. Using botanical names insures the acquisition of the exact plant desired, because common names of plants are not consistent from place to place. The botanical name used in this category consists of two parts, genus and species. Cultivars are horticulturally or agriculturally derived varieties of a plant, and they are usually cultivated for specific characteristics such as color, lack of or production of fruit, or unique foliage characteristics.

### COMMON NAME

Common names of plants vary tremendously from place to place, and are not a reliable identifying feature. Common names are usually of local value, because they derive from laymen gardeners who create names based on some visible characteristic, or reference to a local individual.

### FOLIAGE

**Deciduous:** The tree loses its leaves once a year, usually in the fall.

**Evergreen:** The tree loses its 2-3 year old leaves, usually over a protracted time, most often in spring.

**Fall Color:** The tree produces attractive fall foliage color.

### FLOWER/FRUIT

**Flower Color:** If the tree has ornamental flowers, its colors are listed.

**Flowering Period:** Flowering period by season.

**Fruit:** If the tree produces fruit, it will be described here.

**Fruiting Period:** Fruiting period by season.

### GROWTH/STATURE

**Suitable for Planting Under High Voltage Power Lines:** Trees that are suitable to plant under high voltage power lines must be able to withstand puc pruning requirements without jeopardizing health or structural integrity of tree.

**Shape:** This category identifies the generally definable shape tree canopies take as they mature. As with height, care and urban environments will provide many influencing variables. Tree shapes are defined as follows in this database:

- Columnar = erect and almost parallel, resembling a column
- Conical = oval at the base, elongated and tapering to a narrower width at the top

- Fan Palm = fan shaped leaves with venation of the leaves extending like the ribs of a fan
- Oval = appearing elliptical, resembling an egg
- Rounded = ball-like or circular
- Umbrella = branches extending outward and down, as an umbrella does
- Vase = a narrow base, widening and arching outward towards the top

**Growth Rate per Year (Once Established):** Growth Rate (in inches) identifies the maximum relative rate a tree will grow. As with height, urban environments will provide many influencing variables.

**Height at Maturity:** The maximum height (in feet) to which the species or cultivar may potentially grow in an urban setting. Urban environments may inhibit the potential of a tree to reach the maximum height it would in a natural setting. It is important, though, to consider overhead restrictions before planting a tree.

**Spread at Maturity:** The maximum canopy width (in feet) to which the species or cultivar may potentially grow in an urban setting.

**Trunk Diameter at Breast Height at Maturity:** The maximum diameter of the trunk (in inches) when measured at breast height (4.5 feet above ground level) to which the species may potentially grow in an urban setting.

**Longevity:** The typical lifespan of the species in an urban setting is given in years. Longevity is an important consideration for long-term shading, screening, beauty and value of a property. Short-lived trees may also be wonderful shade trees, and can be useful where permanence is not the ultimate goal. Longevity may vary depending on proper selection of adapted species, care the tree receives, risk of mechanical damage, and the presence or lack of diseases and pests.

## MICROSITE CONDITIONS

**Tolerates Full Sun:** The tree tolerates 6 or more hours of direct sunlight per day.

**Tolerates Shade:** The tree tolerates exposure to high light, but less than 2 hours of direct sunlight per day.

**Requires Good Drainage:** The tree requires good drainage. A soil which drains at the rate of 0.05 inches per hour or more will provide the preferred balance of air, water, and solids ideal for root growth. The very sandy or sandy loam top soils generally found in Alameda are ideal for a broad range of species.

**Tolerates Poor Drainage:** These trees can grow in soils that drain at a rate less than 0.05 inches per hour, such as the clay soils found throughout the fill areas of Alameda.

**Tolerates Moist Soil:** These trees can tolerate damp soil most of the year.

**Drought Tolerant:** These trees are not adversely affected by prolonged periods with little or no rainfall, once established.

**Tolerates Sprinklers:** These are trees that do not react adversely to sprinkler irrigation. Sprinkler watering can favor diseases such as Phytophthora or Armillaria, especially in soils with poor drainage. Some of the native Oak species are particularly susceptible to these diseases. Other species have a natural tendency to grow shallow roots. If they are sprinkler watered, their roots tend to remain even nearer to the surface (where the water is), increasing the likelihood that they will blow over in string winds.

**Seaside Tolerance:** Trees with a checkmark in this column do well when planted along the seaside in this climatic zone.

**Tolerates Alkaline Soil:** These are species that will not be significantly inhibited by growing in soils with pH levels of 7.5-8.7, assuming the high pH levels are caused by high calcium, magnesium, and slightly elevated levels of boron and sodium.

## ROOT ZONE MANAGEMENT

**Minimum Planter Width:** This is the minimum planter space, in feet, in which the species should be used without a root barrier if pavement damage is to be avoided. Even trees listed as tolerant of very small spaces can, in very shallow soils or with sprinkler watering, cause pavement damage.

**Hardscape Damage Potential:** Hardscape Damage Potential attempts to qualify the tendency trees have of causing damage with their roots. Root damage is usually caused when tree roots remain close to the surface of the soil. Tree roots can cause costly damage to paving, structures and even underground utilities. Because roots nearer the tree trunk will enlarge earlier and grow more rapidly, care should be taken to space trees appropriately from structures. Local environmental and tree care conditions, such as soil type or watering habits, can affect a tree's root development. Long, deep waterings can encourage downward root growth. Shallow soils will force roots to grow horizontally rather than vertically.

## NURSERY STATUS

**Nursery Availability:** If the species is grown in California or Oregon, it is listed as having Good availability. If the species was not found to be grown by any major nurseries in California or Oregon, it is listed as having Poor availability. This fact should not deter use of the species or cultivar, only warn the municipal personnel that they may need to source smaller suppliers, or order the tree six months or more in advance.

**Nursery Origin:** This indicates the state that the tree grower's operation is likely to be located. Again, this should not deter the use of the species or cultivar.

**Stock Type:** This notes the method by which this species is commonly sold by growers.

**LITTER ISSUE**

Fruits, flowers, leaves, twigs and bark can be considered litter if they tend to fall with frequency, long duration and abundance. These plant droppings create maintenance hassles when the trees are located over drives, walkways, patios or planting areas which are meant to be kept relatively clean. Problems can include hazardous slippery or bumpy surfaces, staining of surfaces, and smothering of small plants to the point of preventing their growth. However, except for fruits that are sizable and/or wet, most litter is tolerable. Some litter may be left as mulch and contribute to the improvement of the soil. If the tree drops excessive amounts of any of the mentioned plant parts, it is noted here. The fruit type, wet or dry, is also identified.

**PESTS AND DISEASES**

These notes identify pests and diseases by which this species might be threatened or resistant. Different plants attract different pests, and some pests will require special and regular treatments to prevent damage to the tree or its fruit. Disease resistance is a genetic characteristic that determines the tree's ability to resist disease. Trees that are resistant to a disease either do not contract the disease or show little or few symptoms of the disease. Possessing low-level disease symptoms does not significantly affect the health of the tree nor its aesthetic qualities. Because not all trees have been tested for all pests or diseases, much data is not known or documented. This field makes no claim of listing all pests and diseases of any particular tree.

**COMMENTS**

These are special notes as to how this particular species or cultivar will perform as a street tree.

From: Karol Pessin  
1621 Fortmann Way  
Alameda CA 94501  
kpessin@gmail.com

To: Planning, Building and Transportation, City of Alameda, City Hall  
2263 Santa Clara Ave., Room 190  
Alameda CA 94501  
Via E mail to: [dsablan@alamedaca.gov](mailto:dsablan@alamedaca.gov)

Re: 2015 Grand Street

Dear Alameda Planning Board,

These comments are submitted in response to the Notice of Public Hearing, of December 1, 2022. I live right across the street from the old Pennzoil property and have an interest in the development, both for the community as well as a personal interest.

My detailed comments are attached to this letter.

To summarize, while everyone agrees that more housing is necessary, it's difficult to comment on this area of the Northern Waterfront development because the city has yet to advise what it is doing with its maintenance lots. The lots themselves could provide another 2x of similarly dense housing. If that's the case, then the dense housing should be on those lots -- closer to the apartments near Clement, and not in the middle of SFH.

There seems to be a little cat-and-mouse with CEQA. Each in-fill one by one may be exempt -- but considering the area as a whole would result in the impact on air quality from hundreds of thousands of new auto trips per year (per the traffic report).

As to the design itself, the present condo complex is inconsistent with the city's own Northern Waterfront guidance, because it has nothing to do with the character of the surrounding areas.

There are specific concerns -- like blocking sunlight for solar panels, and parking -- as well.

Thank you for your consideration, and making these comments part of the record,  
Karol Pessin

## **Main Points**

- 1. There is patchwork development because the city has not provided guidance on the city lots in the area.**
- 2. The proposed development is inconsistent with the city's Northern Waterfront guidance.**
- 3. Objection to claiming CEQA exemption based on patchwork development**
- 4. Height and Sunlight for surrounding SFH, request for shade/sunlight study, and the effect on solar panels of the surrounding residences.**
- 5. Monolithic block style matches large apartments on Clement, but not surrounding SFH style.**
- 6. Request for open spaces, trees and park like areas.**
- 7. Request for study pertaining to parking for boat ramp and other city and leisure vehicles**

**1. There is patchwork development because the city has not provided guidance on the city lots in the area.**

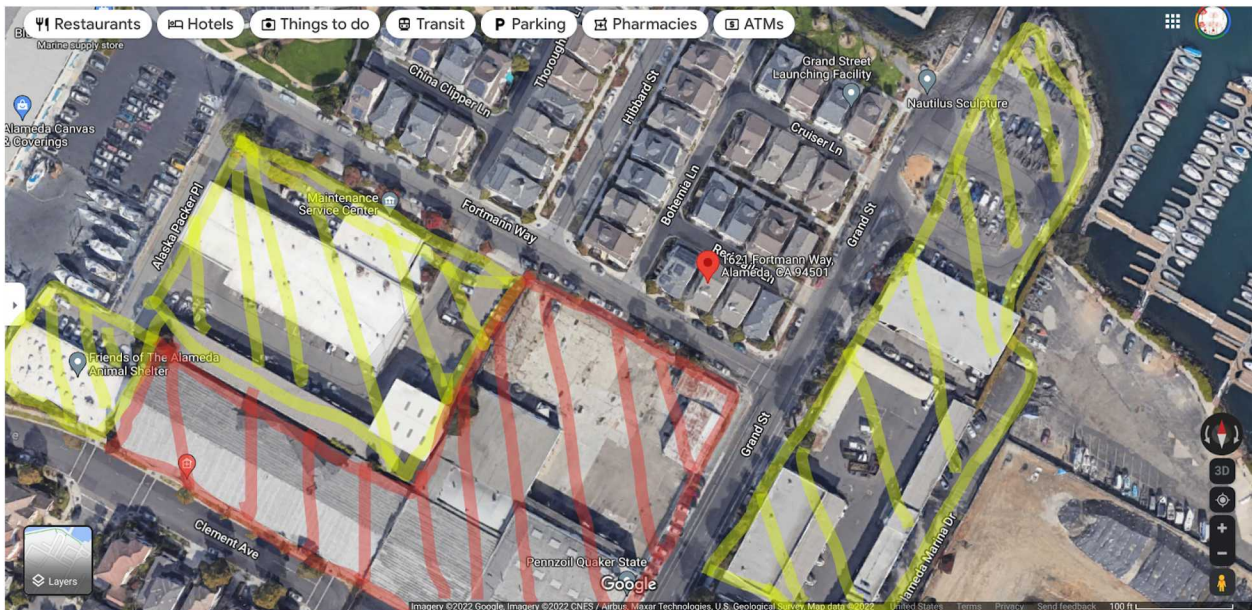

The image above shows the subject Pennzoil lot (red highlighter) and the surrounding city-owned maintenance lots (yellow highlighter).

As can be seen, the city lots would provide space for 2x as much residential development in this area once the city relocates the maintenance lots.

But, the present notice and comment is only on the Pennzoil site.

So what will the final density look like? Will there be parks and open space on the former city lots? Or will the city similarly build large monolithic blocks of dense housing?

Having the public guess at what the final area will look like because the city has provided no guidance as to its maintenance lots is not a good way to plan land use. The city should provide some sort of guidance do the 2015 Grand Street project can be seen in context of the overall area.

**2. The proposed development is inconsistent with the City's Northern Waterfront guidance.**

In the the [Northern Waterfront General Plan Amendment](#), the Guiding and Implementing Policy § 10.3 states in pertinent part::



10.3(a) Require that development in the Northern Waterfront is sensitive to the character of Alameda and the unique waterfront setting.

10.3(b). Require a mix of uses and open space near the Estuary and shoreline that provides for a lively waterfront and a pedestrian friendly environment.

Specifically, 10.3(c) states (emphasis added):

**Pennzoil Site.** Replace the industrial uses at the Pennzoil site **with a mix of new uses such as residential, commercial, and/or public open space.**

The current plan -- large blocky monoliths of highly dense, generically designed housing -- without open space or consideration for surrounding SFH character -- violates the guiding principles the city itself set forth.

While the city had a vision, now it's "well, we're packing in the units, and yes, they're generic looking with no character, but at least it's not Pennzoil."

### **3. Objection to claiming CEQA exemption based on patchwork development**

The plan states that there is no CEQA report required because of an infill exemption, as well as inclusion in the general plan.

But, it seems like taking these infill projects, one by one, where there are likely many more to come, defeats the purpose of CEQA, that is, ensuring air and environmental quality.

The point is that while 2015 Grand, as a stand alone, may fit in the exemption (but even this is questionable), city residents are left guessing if this is only the first of these significant traffic increases.

All potential development should be included together to see if there is significant traffic and CEQA concerns. <sup>1</sup>

---

<sup>1</sup> The CEQA exemption reads (bold added):

15332. IN-FILL DEVELOPMENT PROJECTS Class 32 consists of projects characterized as in-fill development meeting the conditions described in this section.

(a) The project is consistent with the applicable general plan designation and all applicable general plan policies as well as with applicable zoning designation and regulations.

(b) The proposed development occurs within city limits on a project site of no more than five acres substantially surrounded by urban uses.

**4. Height and Sunlight for surrounding SFH, request for shade/sunlight study, and the effect on solar panels of the surrounding residences.**

Buildings will be about 45+ feet high, and built to the curb:

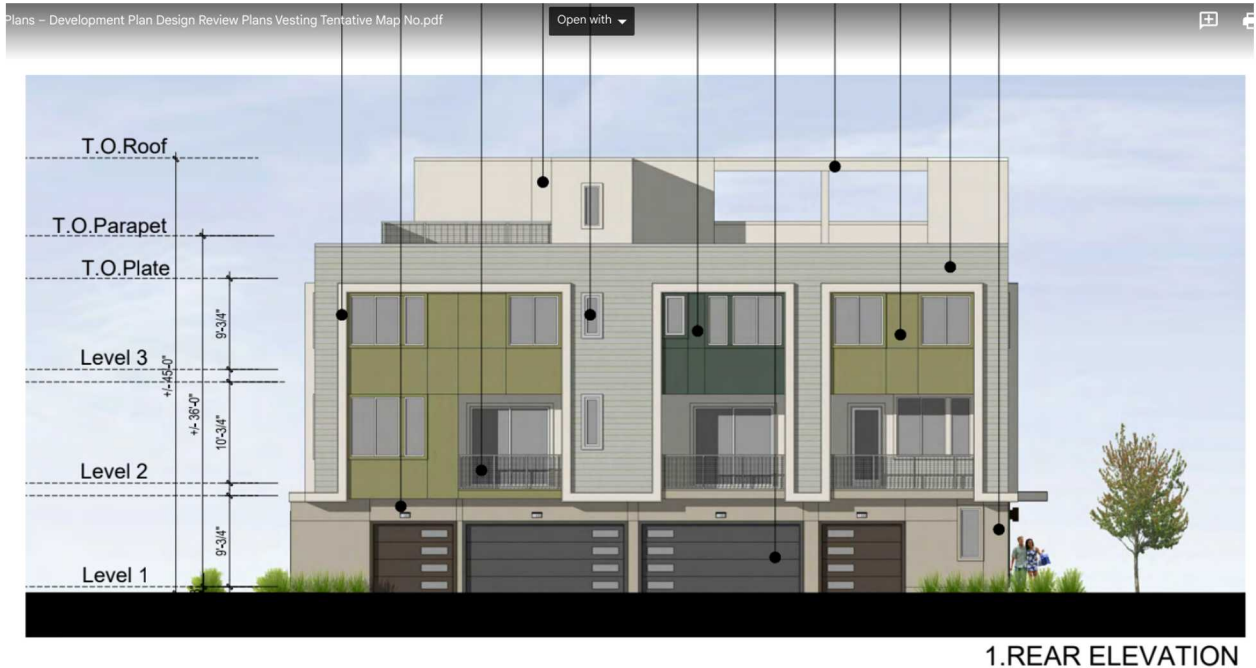

(c) The project site has no value as habitat for endangered, rare or threatened species.

**(d) Approval of the project would not result in any significant effects relating to traffic, noise, air quality, or water quality.**

(e) The site can be adequately served by all required utilities and public services.

The 2015 Grand Transportation Demand Management Plan ("TDM") states:

The 2015 Grand Street Project Transportation Assessment concluded that the project would generate approximately **660 daily** net-new automobile Trips.

This is 231,000 annual new automobile trips (660 x 7 days x 50 weeks). According to a carbon calculator, this would be about 40 metric tons of carbon emitted for a hybrid car, for a 1 mile trip for a year. While this may not be "significant" for CEQA, multiply that by the potential for similar density properties that could be built on the other city lots. If two additional developments are similar, that is almost 700,000 car trips per year, and 1,200 metric tons of carbon (estimated, with hybrid car).

While the standards for "significant" (15332(d)) may vary, avoiding considering the area as a whole seems like a way to avoid CEQA and stick the city citizens with the results no matter what.

There may be additional height for a 3-foot build up to accommodate sea-level rise (letter of September 29,2022, Patricia Curtin to David Sablin.)

While I found no shade study in the city files, one is necessary. Here is an example of a shade estimate on a particular date/time for the location::



<https://shademap.app/@37.77759,-122.25267,17.76345z,1670632015506t,0b,0p,0m>

Buildings close to 50 feet tall will have a significant effect on the sunlight available to surrounding properties. This includes effects on the availability of sun for solar energy panels.

This is not a case of a bunch of Manhattan style skyscrapers already in existence. It is the building of massive blocks of monolithic buildings significantly taller than the SFH that surround them.

Solar Easement request for surrounding properties: I would request a solar easement consistent with California laws (California Civil Code §801.5) for surrounding titleholders who request it.

**5. Monolithic block style matches large apartments on Clement, but not surrounding SFH style.**

The [Northern Waterfront General Plan Amendment](#), Guiding and Implementing Policy § 10.3 states in pertinent part:

**10.3.a. Require that development in the Northern Waterfront is sensitive to the character of Alameda and the unique waterfront setting.**

The guidance uses the term “Require” for sensitivity to the character of Alameda. City leaders used this strong term to let this developer propose this:



This is the basic proposed style, with various wrappings (artificial stone, etc.) for each building. Nowhere in the surrounding SFH does this style make sense. Nor does it comport with the character of the surrounding waterfront in accordance with the City Northern Waterfront guidance document.

Below are two images of the surrounding areas.





That is not the sensitivity to the character of the surrounding area, and violates the city's own guidance.

**6. Request for open spaces, trees and park like areas.** Without knowing what the city has in mind for its properties (yellow highlights, image above), it is difficult to know how much open space, parks, recreational areas will be provided with the development of this area. As it stands now, 2015 Grand has only a small area within the condo complex for recreation, and basically no additional park-like trees or greenery beyond what is already there.

I would provisionally request that the 2015 Grand include more trees or other park-like areas around its perimeters, instead of being built out to the curbs. This would be more consistent with the City's guidelines. If the city uses its maintenance lots as open, park-like areas then this is not as important.

**7. Request for study pertaining to parking for boat ramp and other city and leisure vehicles**

On weekends, due to the boat launch at the bottom of Grand Street, there is quite a bit of truck/boat trailer parking on Fortmann and Grand. During the week, many City employees park on Fortmann, for work at the maintenance facilities next to Alaska Packers..

Currently, the 2015 Grand project plans for 95 units, with 140 garage parking spaces, and 3 guest spaces (per TDM). While there is a suggested \$430 per unit TMA charge (per the TDM, to give each unit a transit pass) there is no indication of whether that will reduce car parking on the nearby streets.

It would be appreciated if the street parking situation could be considered in the overall parking and transportation management.

## Nancy McPeak

---

**From:** David Sablan  
**Sent:** Monday, December 12, 2022 7:41 AM  
**To:** Nancy McPeak  
**Cc:** Allen Tai; Andrew Thomas  
**Subject:** FW: [EXTERNAL] PLN22-0127 - 2015 Grand St.

Hi Nancy,

Can you forward this public comment to the Planning Board and add it to the public comments. Thanks.

-David

---

**From:** Susan Stewart [mailto:scscode10@yahoo.com]  
**Sent:** Sunday, December 11, 2022 4:47 PM  
**To:** David Sablan <DSablan@alamedaca.gov>  
**Subject:** [EXTERNAL] PLN22-0127 - 2015 Grand St.

Please consider my below comments for your board meeting on 12/12/2022 for the subject matter.

I object to the plan as currently proposed for 2015 Grand Street. This plan fails for many reasons:

- 1) it does not provide enough housing for lower income individuals;
- 2) it fails to provide any additional green space for the neighborhood. The green space currently in our neighborhood will not accommodate 90 additional units (figuring on average 2-3 individuals per unit) in addition to all the other construction in the neighborhood.
- 3) it fails to look at traffic congestion with a broader lens. Traffic is already increasing dangerously in our neighborhood because of the warehouse construction and the homes/units on Clement. How can I get off the island if there is a natural disaster or other concern? You can barely get off now and planning board is not considering traffic as a whole with other projects but instead reviewing these matters individually. By the way, a transit pass won't cut it as transit is getting cut back because of lack of increased ridership in a post-COVID world.
- 4) The proposal is too dense for the lot size and a CEQA waiver is not appropriate.
- 5) The intersection of Grand and Clement is a disaster now without new units. I have almost been t-boned numerous times from cars pulling out of Clement and turning left onto Grand. The plan isn't adequate to deal with this intersection let alone the increase of traffic going through a residential neighborhood with lots of families, kids, dogs, seniors, etc.

Although I want to see the lot developed, it would be nice to have more homes that blend with the current neighborhoods on either side of the lot. I realize that developers can't make a big buck but enough is enough about the plans that don't meet density concerns.

Thank you.

Susan Stewart  
2086 Hibbard Street (owner/resident since 2014)  
(805) 341-7557 mobile

**From: Pamela Meluh & James Astwood**

2070 Hibbard St.  
Alameda CA 94501  
[pmeluh@gmail.com](mailto:pmeluh@gmail.com)

**To: Planning, Building and Transportation, City of Alameda, City Hall**

2263 Santa Clara Ave., Room 190  
Alameda CA 94501

Via email to: dsablan@alamedaca.gov

Re: 2015 Grand Street - PLN22-0127

**Dear Alameda Planning Board,**

My husband & I reside in Grand Marina Village, one of the neighborhoods adjacent to 2015 Grand Street, the former Pennzoil site & proposed future site of a housing development that will be discussed at the Planning Board Meeting on Dec. 12. 2022.

Below please find several concerns & questions that my husband (James Astwood) & I have about this site & the proposed development.

**1. What does this statement mean?:** “This project is **categorically exempt from the California Environmental Quality Act (CEQA)** pursuant to the CEQA Guidelines Sections 15332, In-Fill Development and 15183, projects consistent with a General Plan.” To me, this sounds as if the environmental impact of disturbing a former industrial site &/or of building relatively high-density housing on the site does not need to be evaluated or taken into account owing to certain exemptions. If that is indeed the case, I find it very disturbing.

**2. THE FORMER PENNZOIL SITE DOES NOT SEEM SUFFICIENTLY REMEDIATED FOR RESIDENTIAL USE.** Even 2 years after razing the older industrial buildings & structures & removing/replacing some amount of top soil, the proposed site (formal Shell/Pennzoil oil blending commercial site) **continues to give off a foul, noxious stench** on a regular basis (especially noticeable along Grand Ave. on days when there is a prevailing westerly wind). To me this **strongly suggest that the site has not be sufficiently remediated. FURTHER EVALUATION & ASSURANCES TO FOLKS IN THE AREA ARE REQUIRED.** We are very concerned about the impact on air quality & other quality of life issues if no further remediation takes place & the site is then further disturbed during construction. We request a formal study on air quality based on present conditions.

**3. DENSITY OF HOUSING.** The proposal is for **90 (or is it now 95?) new residences – That seems like too much**, especially given all the new units going in at Alameda Marina. Indeed, **90 residences is more than what currently exists in the entire immediate surrounding area (40 in Grand Marina Village; ~27 closest to Ellen Craig & Clement).** Discounting all that is to come



with the Alameda Marina development, more than doubling pedestrian & car traffic & general noise or “churn” in one fell swoop will be a shock to this quiet neighborhood & forever change its “feel”. I especially worry about air quality & noise. I am concerned that inserting such a dense, utilitarian-looking development of monolithic buildings at this location **is aesthetically inconsistent with the surrounding neighborhood** & will decrease nearby property values.

**4. PARKING.** The plan should not be approved unless it includes sufficient parking for a **realistic number of vehicles within its boundaries**. This is critical. With the nearby City Public Works site claiming parking along one side of Fortmann Way during the work week, ongoing development at Alameda Marina & the installation of the major bike lane on Clement, there is very little street parking available in this area. Also given that the boat launch facility at the end of Grand St has limited parking, boaters often need to park their trucks & boat trailers along Grand St & sometimes on Fortmann Way during the fishing seasons. The developer cannot count on regular City of Alameda street parking as a spill-over parking solution. I see that the proposed design does include ground level parking garages for most (all?) units, but not every garage has 2 spaces. In my opinion, **“realistic” parking for 90 residences means at least 180 parking spaces** for residents, plus additional visitor parking. Where do visitors park in this development? Will there be parking allowed on any of the internal streets? I think they might need to have fewer units & add a parking lot in the plan.

**5. TRAFFIC CONSIDERATIONS.** The intersection at Clement Ave & Grand St is a busy one. These streets are currently part of the “truck route” & soon there will be additional traffic coming & going from the Alameda Marina housing development. Clement traffic currently has a STOP sign, whereas Grand traffic has the right-of-way. What might not be appreciated is that Clement & Grand is also a **dangerous intersection**, mainly because Clement traffic – *including bicycle traffic* – frequently fails to stop at their STOP sign or fails to yield the right-of-way. Driving on Grand, I need to slam on my brakes at least once a week to avoid collision with vehicles entering Grand from Clement. A 4-way stop is being suggested for the future Clement Ave & Grand St intersection. I think a traffic light or perhaps a traffic circle (more flow), would be a better choice.

**6. SIDEWALKS.** As this area continues to be “gentrified” & more families with children move in, it is critical to have clearly designated & well-structured sidewalks on both sides of Grand St. It looks as if the proposal only has sidewalks going in on the northwest side of Grand. For reasons of safety & access, the City of Alameda or the Developer should install good sidewalks on both sides of the street.

**7. PLAYGROUNDS, OUTDOOR SPACE.** I think a lot of us hoped that all or part of the vacated Pennzoil site would be turned into a park or a playground/sports area (e.g. basketball court &/or soccer field, etc.). The current proposal for the site contains no public open space even though it would instantly double the density of residences in the immediate area. Right now, there’s nowhere in this general area for people (especially young people) to get outside & play, yet there is a clear need for this since playing in the streets is not an option. As mentioned above, traffic on Clement St. & Grand Ave. & even Fortmann Ave. is fairly heavy. The closest

park (near FAAS & Grand Marina – I'm not sure of its name) has a few picnic tables, but is otherwise not improved. Moreover, this open space is often used as a dog run & for the past year or so, it's where a few homeless people have been living, so it's really not the best place for young people to play. I think the **City of Alameda should require the developer to turn part of the Pennzoil property into green space for the neighborhood, or the City itself should purchase part of the property for this purpose.** Perhaps the need for nearby open space/play area is addressed in the Alameda Marina development plan, but I have been unable to find "park-like areas" in that plan.

Antony and Fei Ouyang  
1603 Fortmann Way  
Alameda, CA 94501  
[feitony@googlegroups.com](mailto:feitony@googlegroups.com)

Andrew Thomas and Members of the Alameda Planning • Building • Transportation Department  
City Hall Ground Floor  
2263 Santa Clara Ave Room 190  
Alameda, CA 94501

### **RE: Proposed 2015 Grand Street Development**

We would like to submit our comments into the public record as part of the public hearing on Monday December 12, 2022 to consider development of the former Pennzoil site on 2015 Grand Street.

We are homeowners in the neighboring Fortmann Marina and have lived here since 2010. As such we'll be impacted by the proposed 2015 Grand Street development.

Broadly we want to voice a couple concerns regarding this development.

- **Impact to parking within a two block radius of the proposed development and increase traffic in the area**

Of the 95 mixed condos being proposed, there are only 140 garage spaces/dedicated parking spots (~1.59 parking spots per unit) and **only 3 guest spaces**. Per the TDM plan the 1.59 off-street parking spaces per unit is less than the auto ownership in the project area of 1.64.

The development proposes that 44% of units will have only have one parking space; this suggests that ~42 units (95 total units x .44) will have only one parking space. Even assuming that only half of the residents living in these 42 units have two cars, that could mean an extra ~21 cars that will need to find street parking in/around the Fortmann Marina, Grand Marina neighborhood, and Fortmann Way, Grand Street, and Clement Ave.

Additionally, the TDM Plan proposed by Trumark (the developer) does not seem to adequately address the potential increase in traffic. For example, providing one AC Transit Easy Pass per residential unit (each residential unit will likely have more than one resident) will unlikely be sufficient enough in dis-incentivizing single occupancy vehicle usage. The overall TDM plan is expected to only reduce estimated vehicle trips from 1-3%.

**We would like to see a more comprehensive plan to address potential street parking issues and increases in traffic in the surrounding area.**

- **The building design does not conform with the surrounding Northern Waterfront guidance**



Per the Northern Waterfront General Plan Amendment

10.3(a) Require that development in the Northern Waterfront is sensitive to the character of Alameda and the unique waterfront setting.

Implementing Policies: Land Use

10.3.c.

*Pennzoil Site. Replace the industrial uses at the Pennzoil site with a mix of new uses such as residential, commercial, and/or public open space.*

The proposed design does not seem to conform to either of these requirements as stated within the Northern Waterfront General Plan Amendment. The building design looks rather generic, boxy, and does not reflect the character of the Northern Waterfront.

**We would like to see a design that better reflects the maritime history and/or existing home styles as currently reflected within the Northern Waterfront area and neighborhood.**

In addition the proposed construction by Trumark does not contain (emphasis ours) “**a mix of new uses** such as residential, commercial, and/or public open space” but rather just contains residential units.

**We would also like to see some public open space incorporated into the building plan.**

- **Traffic Safety Considerations**

As daily weekday bicycle commuters to Maya Lin Elementary School and ACLC Charter School, our family of 4 rides on the Western portion of Clement 3-5x per week. We’ve already noticed that the traffic on the Western side of Clement (from Grande St) has dramatically increased, and cars often speed on this portion of Clement.

We are happy to see that the plan includes “new crosswalks with high-visibility markings are also proposed for the west, north, and south legs of the Clement Avenue/Grand Street intersection.” as part of an extension of Clement to connect to Grand St. as well as “New crosswalks with high-visibility markings would be constructed on all four legs of the Hibbard Street/Clement Avenue intersection.”

That being said, we are still concerned about an even higher increase of traffic expected from the East side of Clement connecting through to Hibbard St. on the new block of Clement Ave between Hibbard and Grand Streets.

**We request further consideration of traffic safety improvements on the intersections of Clement Avenue/Grand Street and (the new) Hibbard Street/Clement Avenue.**

Thanks for your time and consideration of our concerns about the proposed 2015 Grand Street development project.

We love Alameda and want to make sure that any further developments in our “little” city take into consideration all valid concerns from the community, especially when it comes to safety (traffic) and quality of life issues (parking, consistent designs with neighborhood).

Sincerely,

Antony Ouyang  
Fei Ouyang