

**ALAMEDA POINT - SITE A
BLOCK 11 + SHARED PLAZA
HISTORICAL ADVISORY BOARD
MARCH 3, 2016**

ALAMEDA POINT BLOCK 11 | ALAMEDA, CA

COVER SHEET

BARarchitects

901 Battery Street, Suite 300 | San Francisco, CA 94111 | 415 293 5700 | www.bararch.com



SHERRILL - MADISON MARQUETTE
THOMPSON DORFMAN PARTNERS - TRAMMELL CROW RESIDENTIAL

14095

03.03.16



BLOCK 11 HAB MEETING MARCH 3, 2016

VICINITY MAP

ZONING & OPEN SPACE

<p>ZONING DATA:</p> <p>ALAMEDA POINT DEVELOPMENT PLAN</p>	<p>SITE AREA CALCULATIONS:</p> <p>GROSS SITE AREA: 2.58 ACRES TOTAL OPEN SPACE AREA: 1.26 ACRES</p>	<p>BUILDING OPEN SPACE:</p> <p>RESI. COMMON SPACE (COURTYARD/ROOF DECK): 36,465 SF PROVIDED 34,100 SF REQUIRED</p> <p>RESI. PRIVATE SPACE (PATIOS/BALCONIES): 18,526 SF</p>
---	---	---

PROJECT TEAM

<p>OWNER:</p> <p>THOMPSON DORFMAN PARTNERS, LLC 39 FORREST STREET, SUITE 201 MILL VALLEY, CA 94941 T: (415) 381-3001 CONTACT: BRUCE DORFMAN EMAIL: BD@THOMPSONDORFMAN.COM</p>	<p>ARCHITECT:</p> <p>BAR ARCHITECTS 901 BATTERY ST., #300 SAN FRANCISCO, CA 94111 T: (415) 293-5700 CONTACT: DAVID ISRAEL EMAIL: DISRAEL@BARARCH.COM</p>	<p>SHARED PLAZA LANDSCAPE ARCHITECT:</p> <p>GLS LANDSCAPE 2677 MISSION ST. #200 SAN FRANCISCO, CA 94110 T: (415) 285-3614 CONTACT: DEAN WILLIAMS EMAIL: DEAN@DLSARCH.COM</p>	<p>BLOCK 11 LANDSCAPE ARCHITECT:</p> <p>FLETCHER STUDIO 2325 3RD ST. SUITE 413 SAN FRANCISCO, CA 94107 T: (415) 230-9144 CONTACT: DAVID FLETCHER EMAIL: DFLETCHER@FLETCHERSTUDIO.COM</p>	<p>CIVIL ENGINEER:</p> <p>BKF ENGINEERS 150 CALIFORNIA ST. #650 SAN FRANCISCO, CA 94111 T: (415) 930-7900 CONTACT: DANIEL SCHAEFER EMAIL: DSCHAEFER@BKF.COM</p>
--	---	---	---	--

BUILDING & PARKING STATISTICS

UNIT COUNT	UNIT TYPE				FUNCTION	AREA (GSF)							TOTALS
	1 BR, 1 BA	2 BR, 2 BA	2 BR, 2 BA TH	3 BR, 2 BA		L1	L2	L3	L4	L5	L6	L7	
AVERAGE GSF/D.U.	775	1092	1397	1520	RES. UNITS	4477	4594	47963	47963	51171	51171	48116	255456
LEVEL 1			6		RES. LOBBY	2220							2220
LEVEL 2					RES. TRASH	664	228	620	296	296		217	2621
LEVEL 3	12	23		7	RES. AMENITY	310		2695	1545			1355	5905
LEVEL 4	12	23		7	LEASING / CAFE	2008							2008
LEVEL 5	12	23		9	RETAIL	21947							21947
LEVEL 6	12	23		9	RETAIL TRASH	134							134
LEVEL 7	13	21		8	STORAGE	2623	1181	497	822	822	822	822	7588
TOTAL	61	113	6	40	LOADING	1677							1677
% TOTAL MIX	27%	52%	3%	18%	BIKE STORAGE	3287							3287
					MEP	2165	375	622	622	622	622	701	5729
					PARKING	46736	54250						100986
					CIRCULATION	4546	2074	7392	7392	7496	7496	7496	43892
						92799	62703	59790	58638	60407	60407	58707	453452

DRAWING INDEX

- 1 COVER SHEET
- 2 INFO SHEET
- 3 SITE A PHOTOS
- 4 SITE A EXISTING CONDITIONS
- 5 SITE A PROPOSED
- 6 SITE PLAN
- 7 SHARED PLAZA KEY PLAN
- 8 SITE PLAN WITH SECTION - ELEVATION
- 9 SITE PLAN WITH SECTION - ELEVATION
- 10 PAN AM WITH SECTION - ELEVATION
- 11 BLOCK 11 NORTH ALLEY SECTION - ELEVATION
- 12 SHARED PLAZA KEY PLAN
- 13 SHARED PLAZA PRECEDENT IMAGES
- 14 SITE A STORM WATER BASIN FURNISHINGS
- 15 VIEW FROM WATERFRONT
- 16 VIEW FROM SOUTHEAST
- 17 SOUTH ELEVATION
- 18 SOUTH ELEVATION + DESIGN REFERENCES
- 19 ENLARGED SOUTH ELEVATION + DESIGN REFERENCES
- 20 RETAIL STREET VIEW
- 21 WEST ELEVATION
- 22 ENLARGED WEST ELEVATION + DESIGN REFERENCE
- 23 PERSPECTIVE VIEW ALONG PAN AM WAY
- 24 NORTH ELEVATION
- 25 ENLARGED NORTH ELEVATION + DESIGN REFERENCES
- 26 EAST ELEVATION
- 27 ENLARGED EAST ELEVATION + DESIGN REFERENCES
- 28 FERRY POINT WAY STREET VIEW
- 29 COURTYARD ELEVATIONS
- 30 COURTYARD ELEVATIONS
- 31 COURTYARD ELEVATIONS
- 32 VIEW OF COURTYARD TOWARD COMMUNITY ROOM
- 33 VIEW FROM NORTHWEST
- 34 VIEW FROM NORTHEAST
- 35 FLOOR PLANS
- 36 FLOOR PLANS
- 37 FLOOR PLANS
- 38 LANDSCAPE SITE PLAN - LEVEL 1
- 39 LANDSCAPE SITE PLAN - LEVEL 2
- 40 LANDSCAPE SITE PLAN - LEVEL 3
- 41 PRELIMINARY STORMWATER MANAGEMENT PLAN
- 42 LIFE SAFETY DIAGRAMS
- 43 VIEW FROM WATERFRONT
- 44 UNIT PLANS

ALAMEDA POINT BLOCK 11 | ALAMEDA, CA

INFO SHEET

COPYRIGHT 2015



ALAMEDA POINT BLOCK 11 | ALAMEDA, CA

SITE A PHOTOS

BARarchitects

901 Battery Street, Suite 300 | San Francisco, CA 94111 | 415 293 5700 | www.bararch.com



SRINIVAS - MADISON MARQUETTE
THOMPSON DORFMAN PARTNERS - TRAMMELL CROW RESIDENTIAL

14095

03.03.16

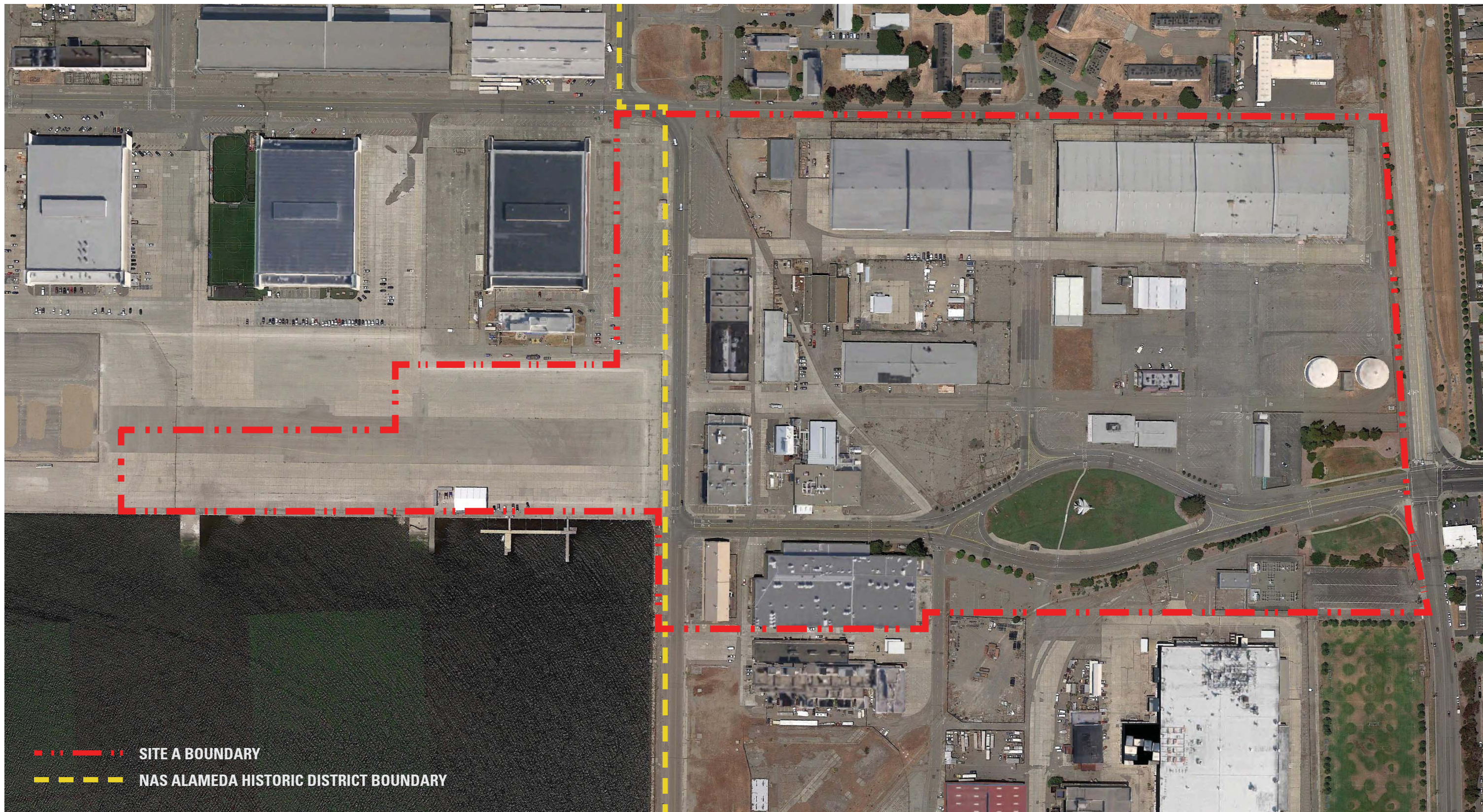

- - - SITE A BOUNDARY
- - - NAS ALAMEDA HISTORIC DISTRICT BOUNDARY

ALAMEDA POINT BLOCK 11 | ALAMEDA, CA

SITE A EXISTING CONDITIONS

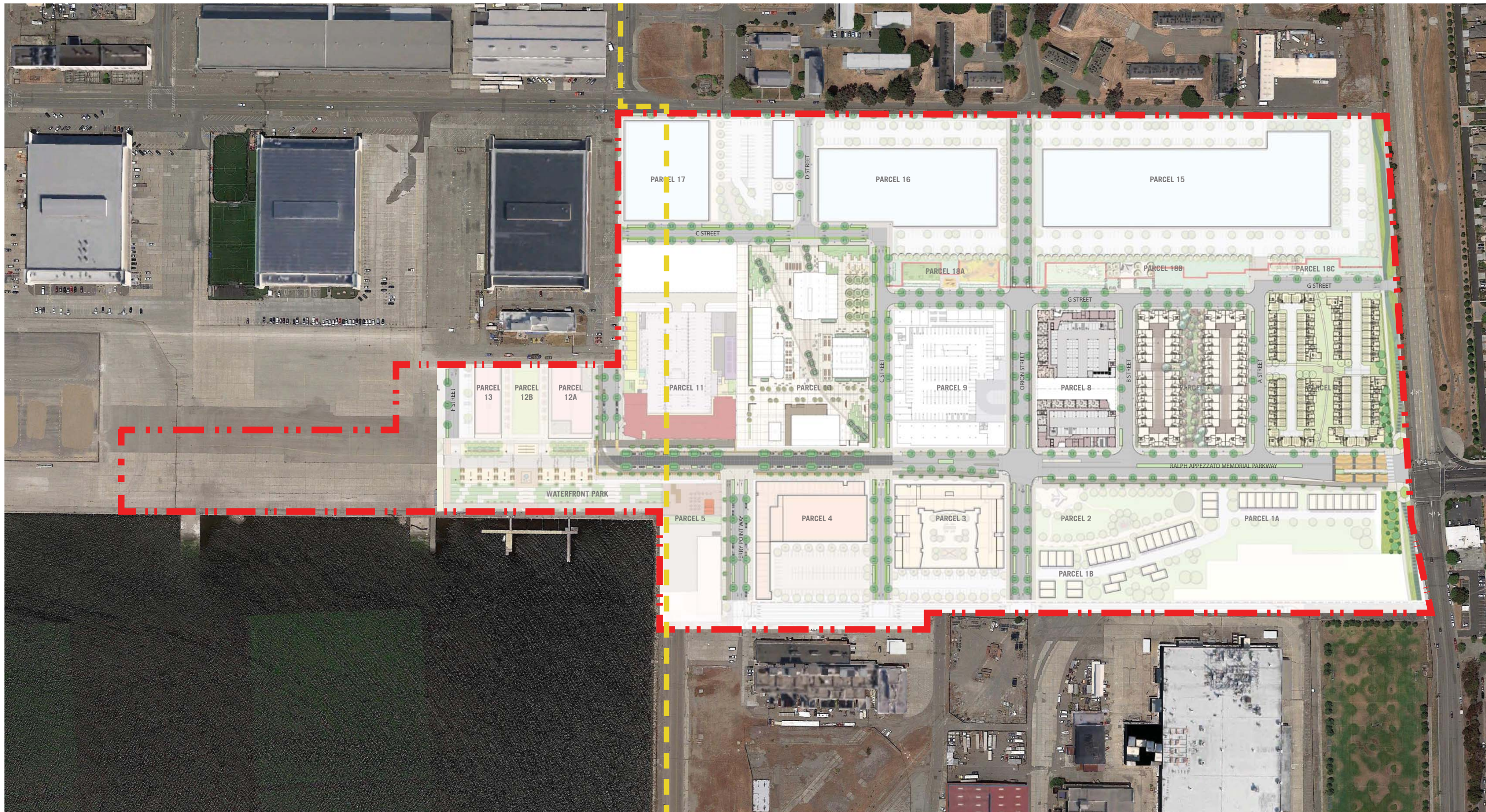

ALAMEDA POINT BLOCK 11 | ALAMEDA, CA

SITE A PROPOSED

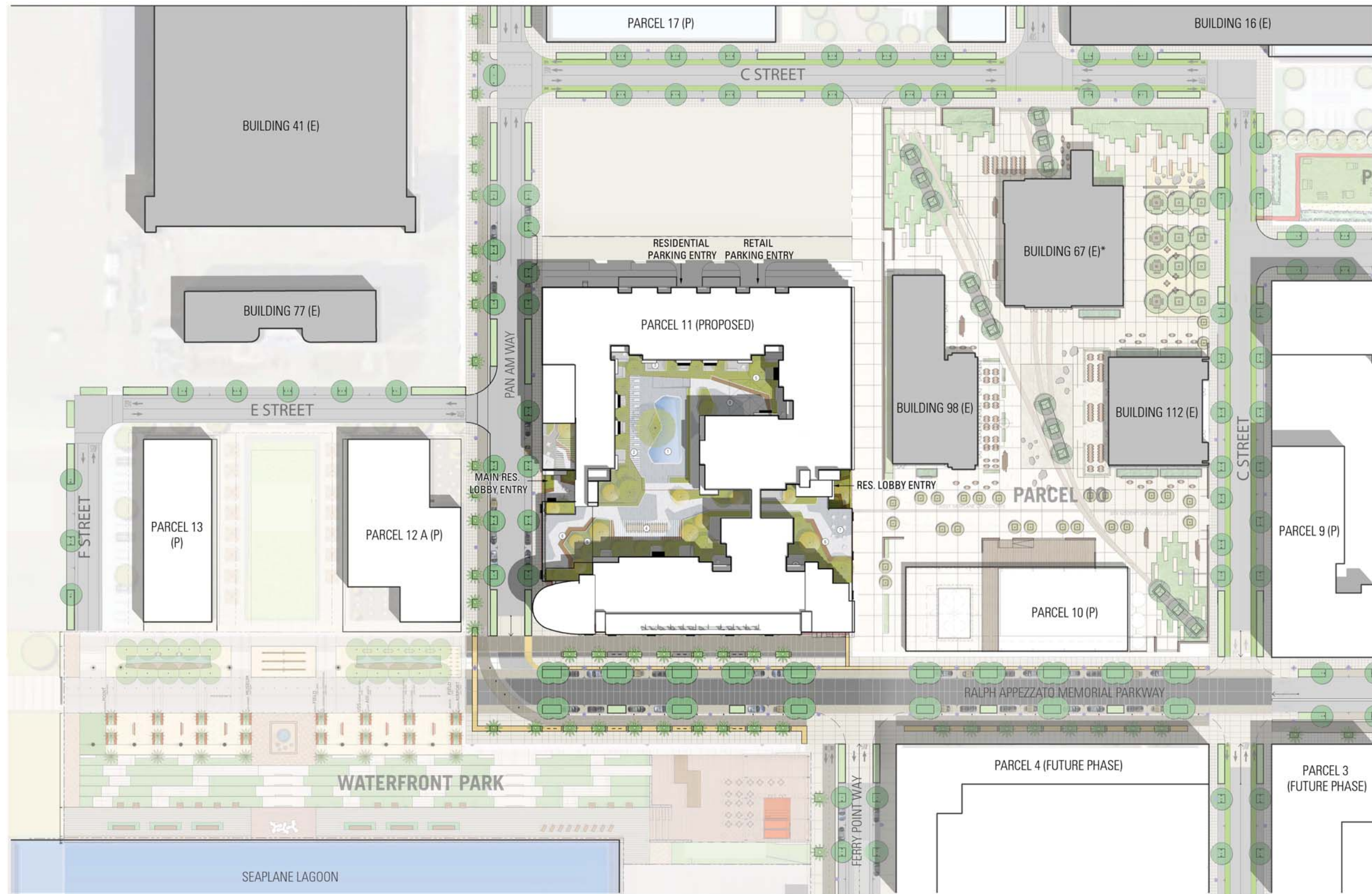

1 SITE PLAN
2

ALAMEDA POINT BLOCK 11 | ALAMEDA, CA

SITE PLAN

COPYRIGHT 2015
COPYRIGHT 2015

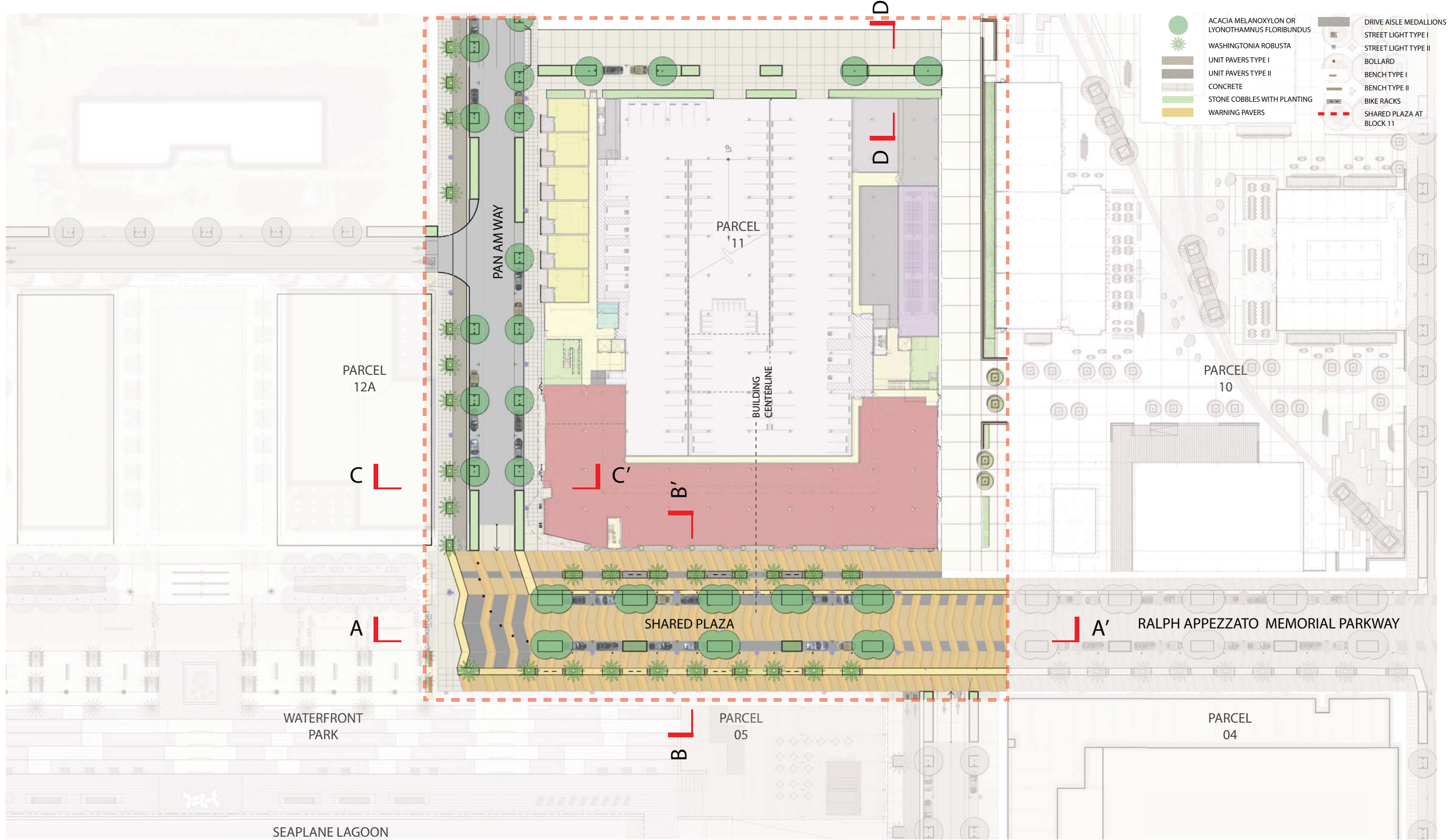

ALAMEDA POINT BLOCK 11 | ALAMEDA, CA

SHARED PLAZA KEY PLAN



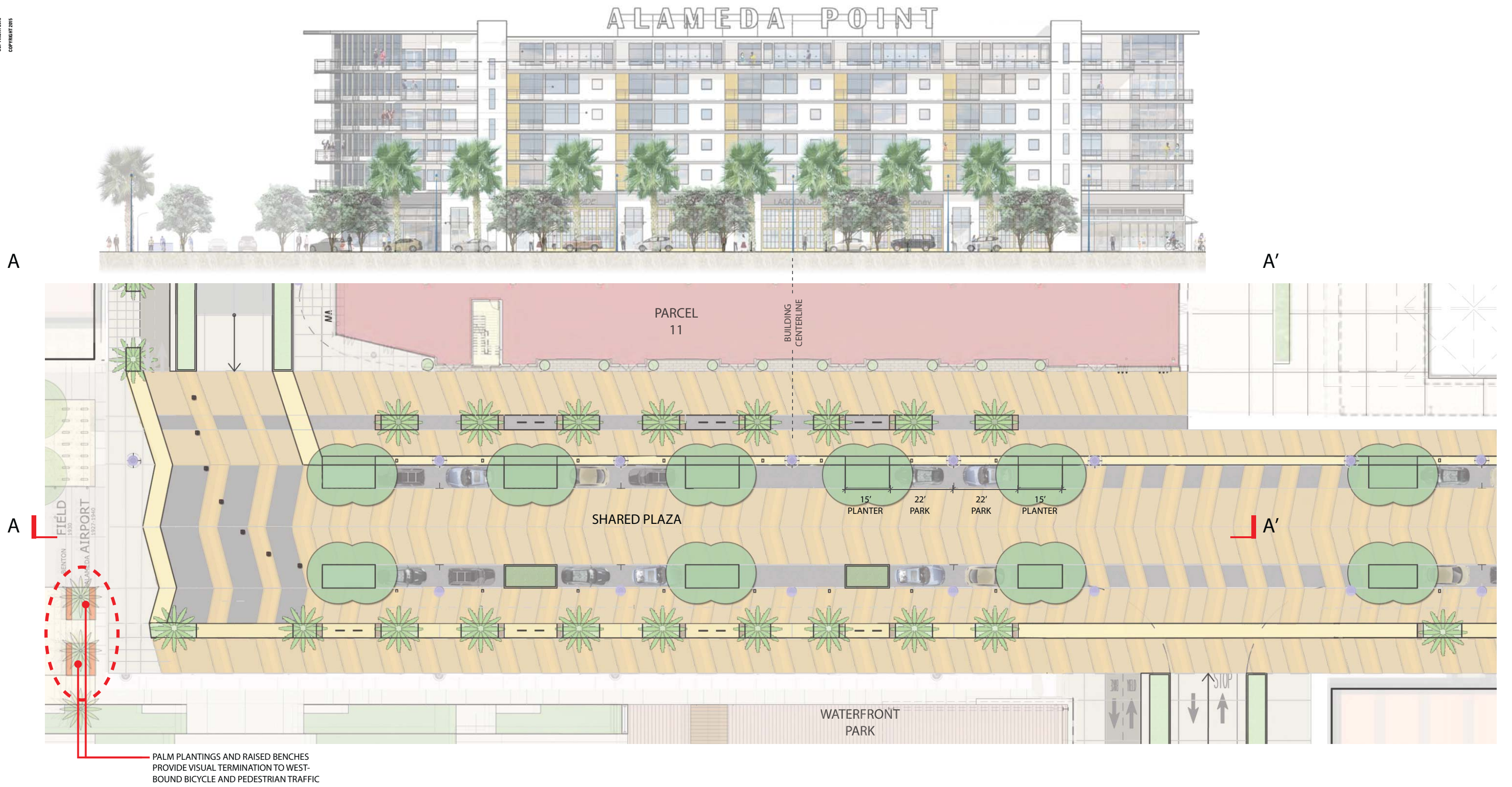

ALAMEDA POINT BLOCK 11 | ALAMEDA, CA

SITE PLAN WITH SECTION - ELEVATION

B



B'

B

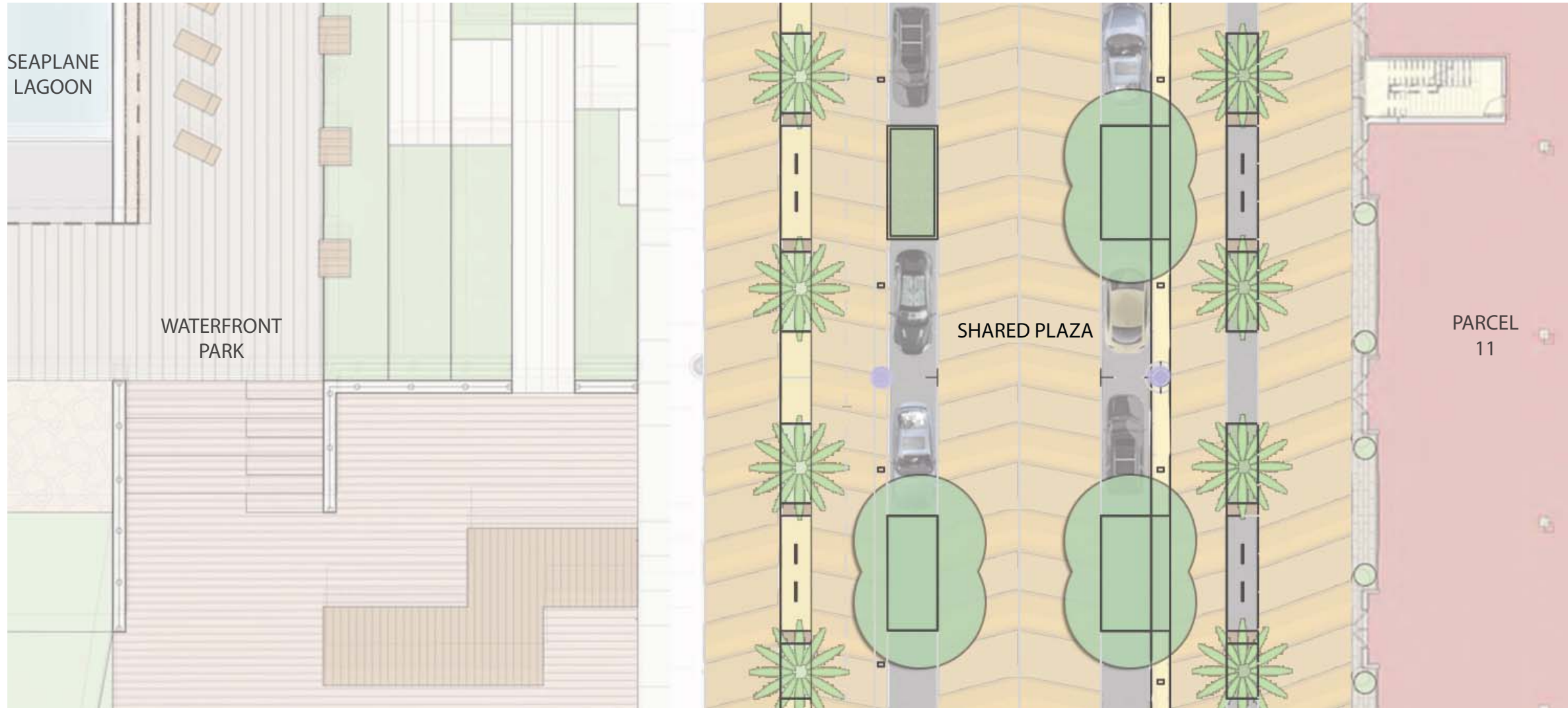

B'

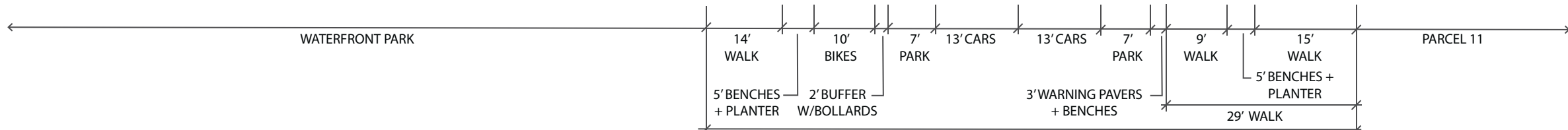

ALAMEDA POINT BLOCK 11 | ALAMEDA, CA

SITE PLAN WITH SECTION - ELEVATION

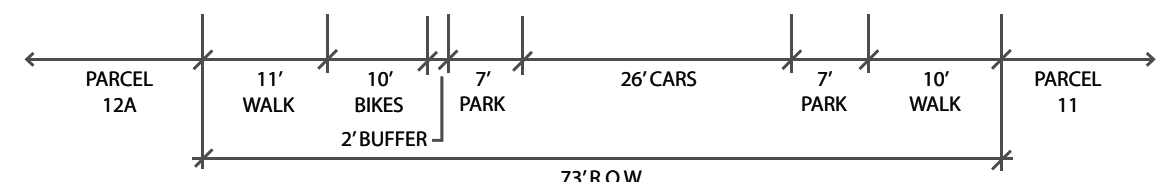
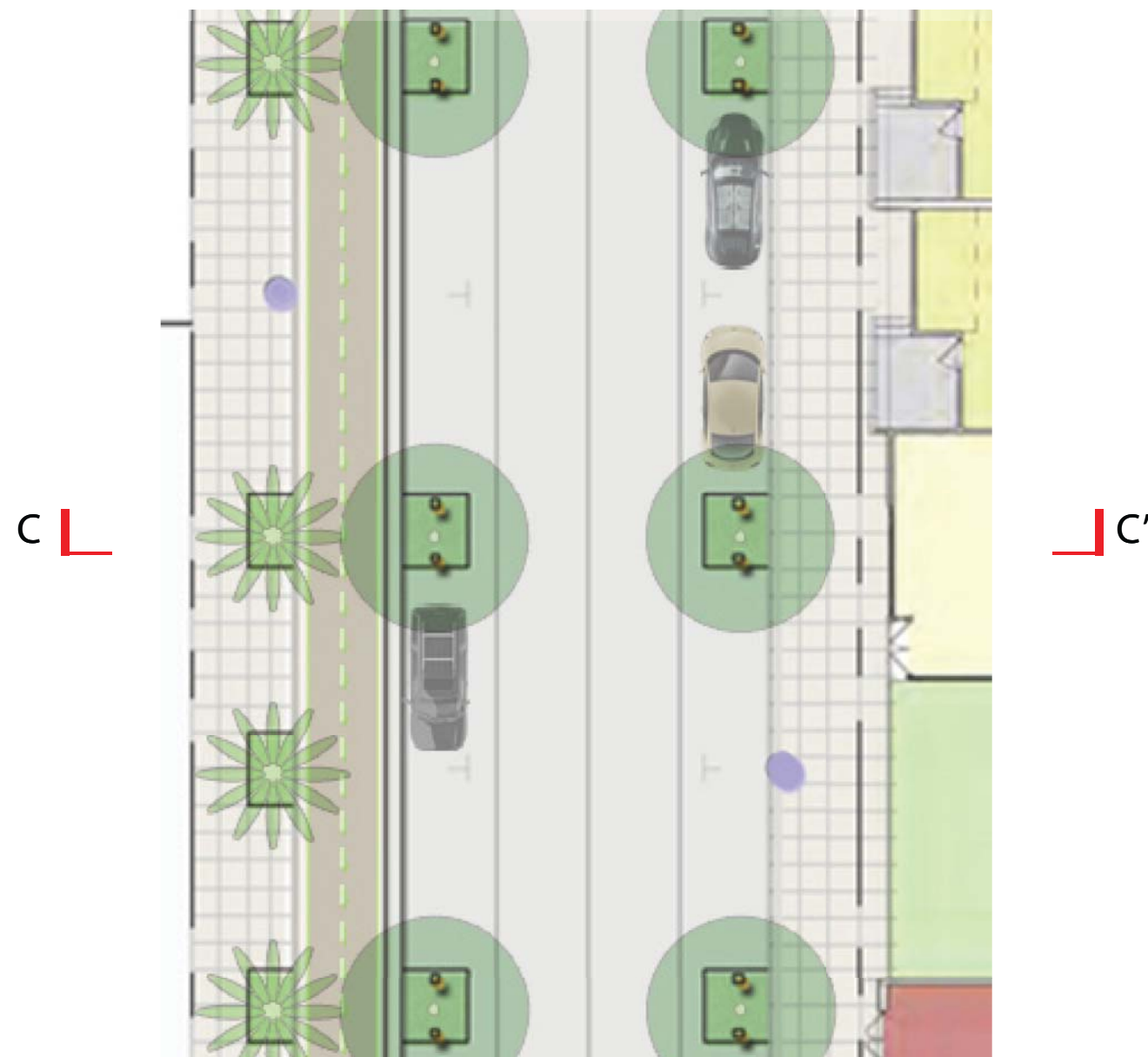

ALAMEDA POINT BLOCK 11 | ALAMEDA, CA

PAN AM WITH SECTION - ELEVATION

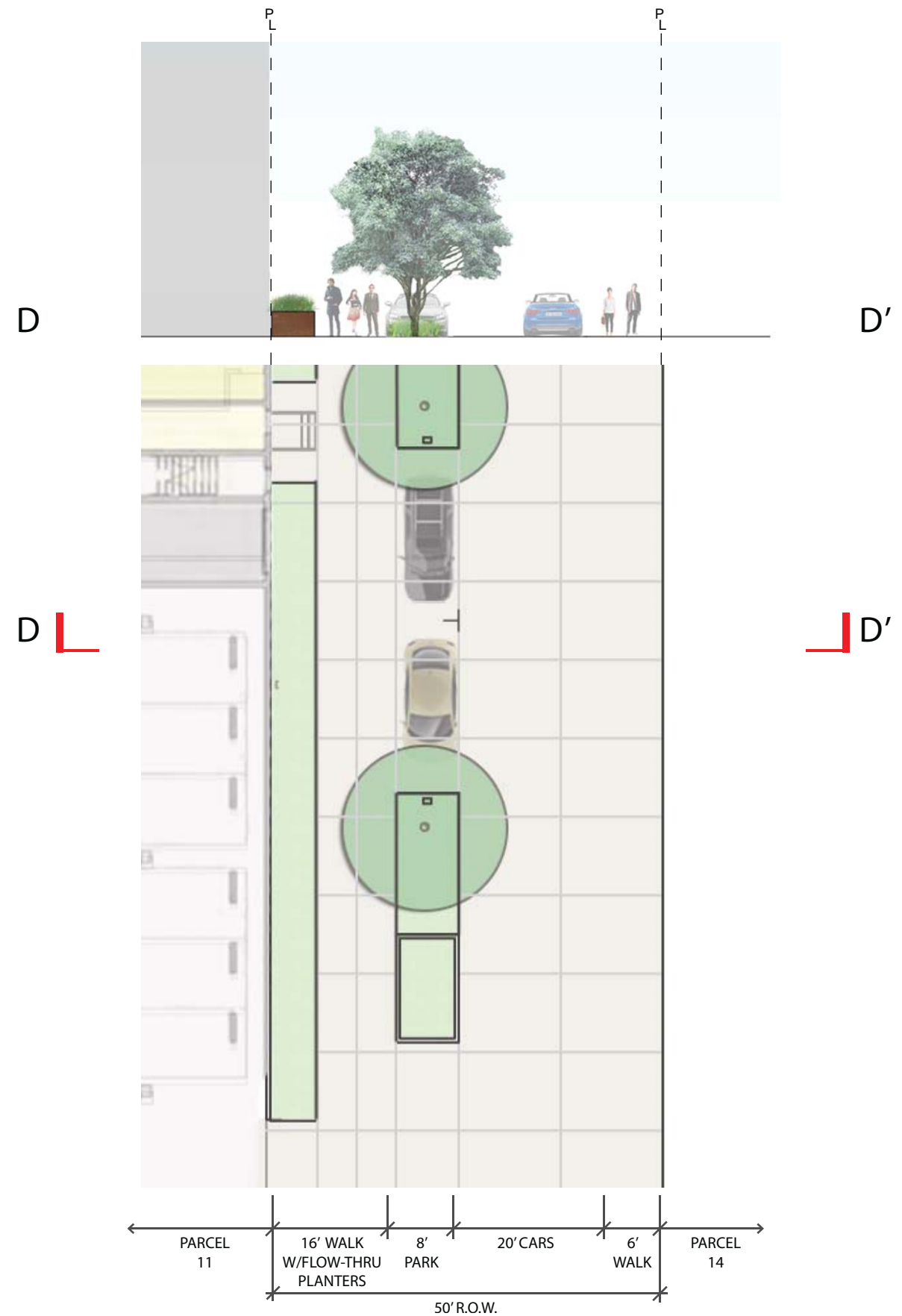

ALAMEDA POINT BLOCK 11 | ALAMEDA, CA

BLOCK 11 NORTH ALLEY SECTION - ELEVATION



STONE COBBLES AT TREE WELLS



BIKE RACK



BOLLARD



CONCRETE

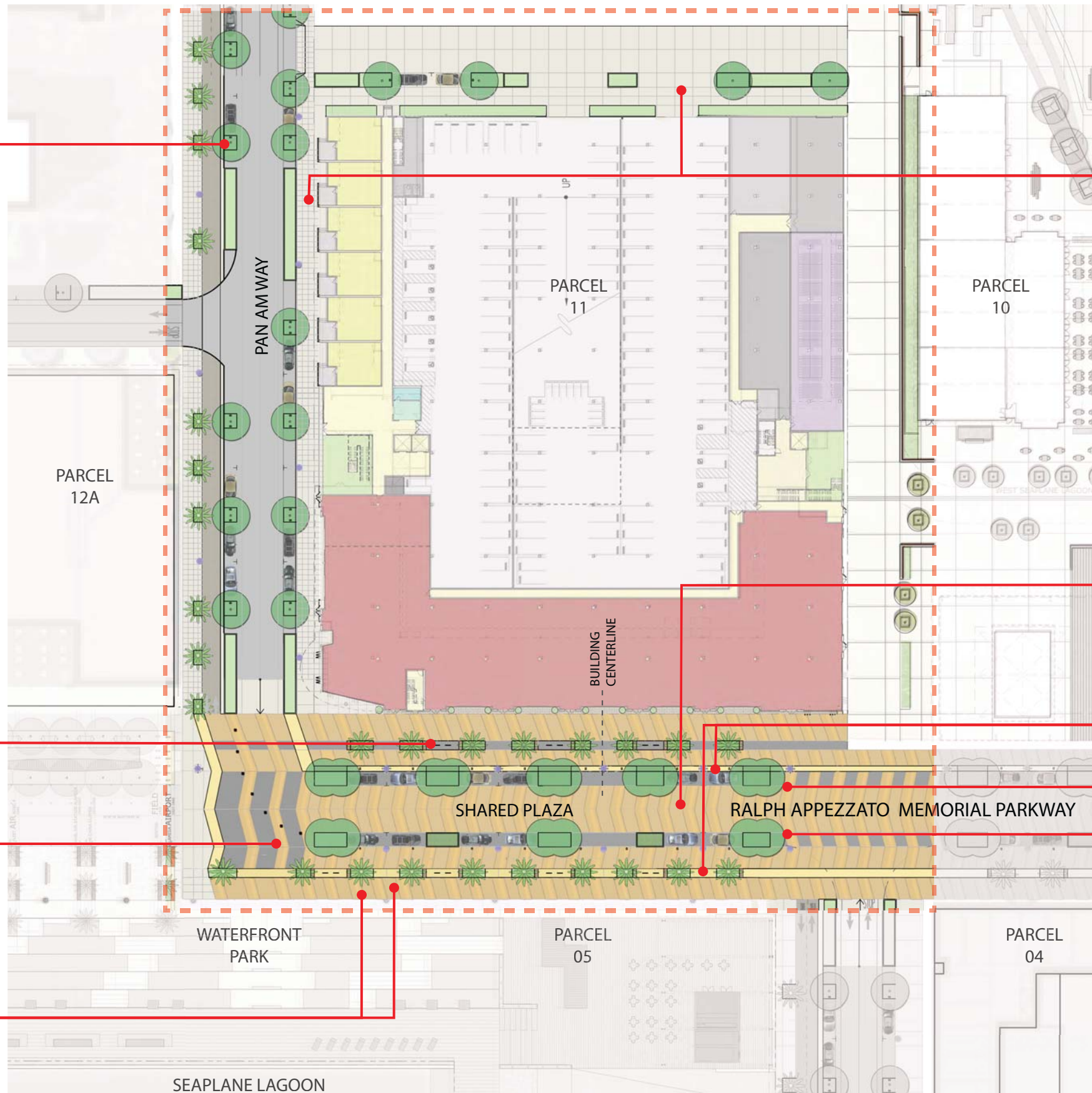

- ACACIA MELANOXYLON OR LYONOTHAMNUS FLORIBUNDUS
- WASHINGTONIA ROBUSTA
- UNIT PAVERS TYPE I
- UNIT PAVERS TYPE II
- CONCRETE
- STONE COBBLES WITH PLANTING
- WARNING PAVERS
- DRIVE AISLE MEDALLIONS
- STREET LIGHT TYPE I
- STREET LIGHT TYPE II
- BOLLARD
- BENCH TYPE I
- BENCH TYPE II
- BIKE RACKS
- SHARED PLAZA AT BLOCK 11



CONCRETE



UNIT PAVERS TYPE I



CAST IRON WARNING PAVER



DRIVE AISLE MEDALLION

ALAMEDA POINT BLOCK 11 | ALAMEDA, CA

SHARED PLAZA KEY PLAN

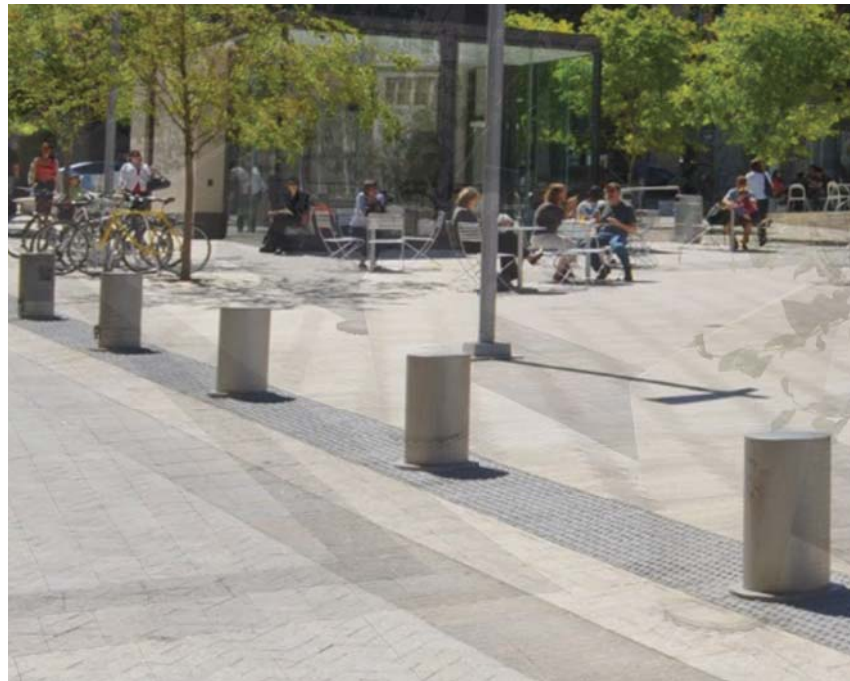

ALAMEDA POINT BLOCK 11 | ALAMEDA, CA

SHARED PLAZA PRECEDENT IMAGES



ALAMEDA POINT BLOCK 11 | ALAMEDA, CA

SITE A STORM WATER BASIN FURNISHINGS



ALAMEDA POINT BLOCK 11 | ALAMEDA, CA

VIEW FROM WATERFRONT



ALAMEDA POINT BLOCK 11 | ALAMEDA, CA

VIEW FROM SOUTHEAST



EXTERIOR ELEVATION - SOUTH

3/32" = 1'-0"

ALAMEDA POINT BLOCK 11 | ALAMEDA, CA

SOUTH ELEVATION

COPYRIGHT 2015

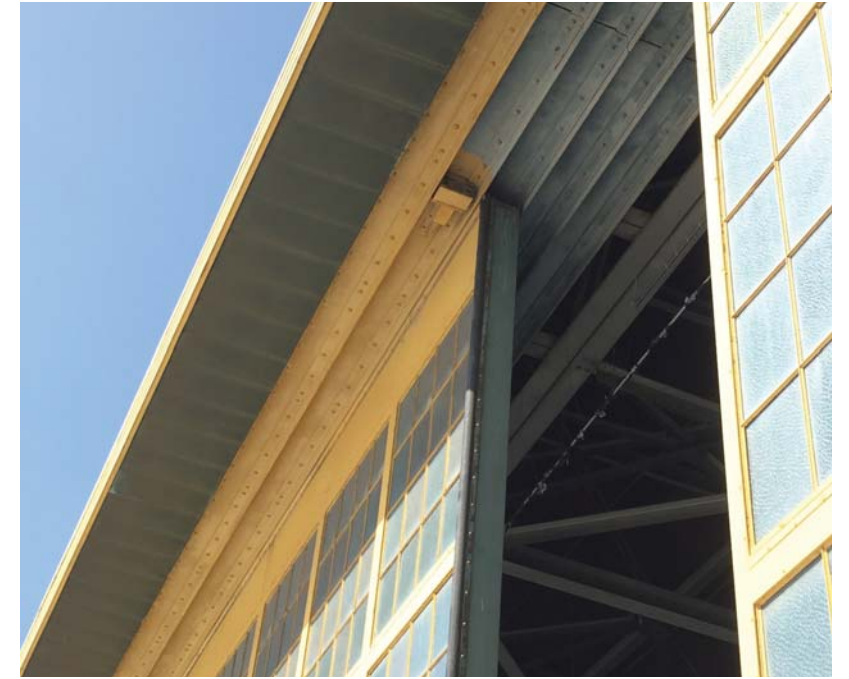
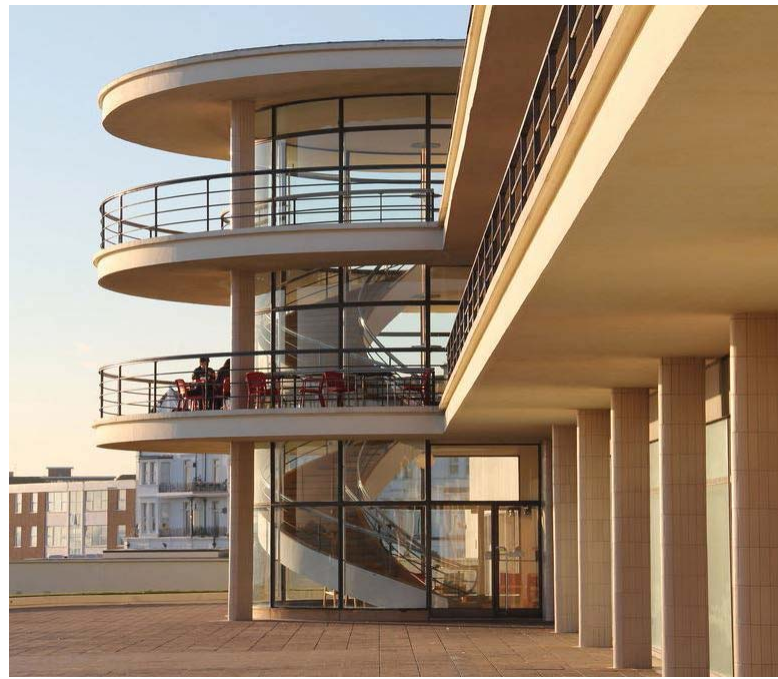

ALAMEDA POINT BLOCK 11 | ALAMEDA, CA

SOUTH ELEVATION + DESIGN REFERENCES



ALAMEDA POINT BLOCK 11 | ALAMEDA, CA

ENLARGED SOUTH ELEVATION + DESIGN REFERENCES



ALAMEDA POINT BLOCK 11 | ALAMEDA, CA

RETAIL STREET VIEW



ALAMEDA POINT BLOCK 11 | ALAMEDA, CA

WEST ELEVATION



BUILDING 77



ALAMEDA POINT BLOCK 11 | ALAMEDA, CA

ENLARGED WEST ELEVATION + DESIGN REFERENCE



ALAMEDA POINT BLOCK 11 | ALAMEDA, CA

PERSPECTIVE VIEW ALONG PAN AM WAY



EXTERIOR ELEVATION - NORTH

3/32" = 1'-0"

ALAMEDA POINT BLOCK 11 | ALAMEDA, CA

NORTH ELEVATION



ALAMEDA POINT BLOCK 11 | ALAMEDA, CA

ENLARGED NORTH ELEVATION + DESIGN REFERENCES

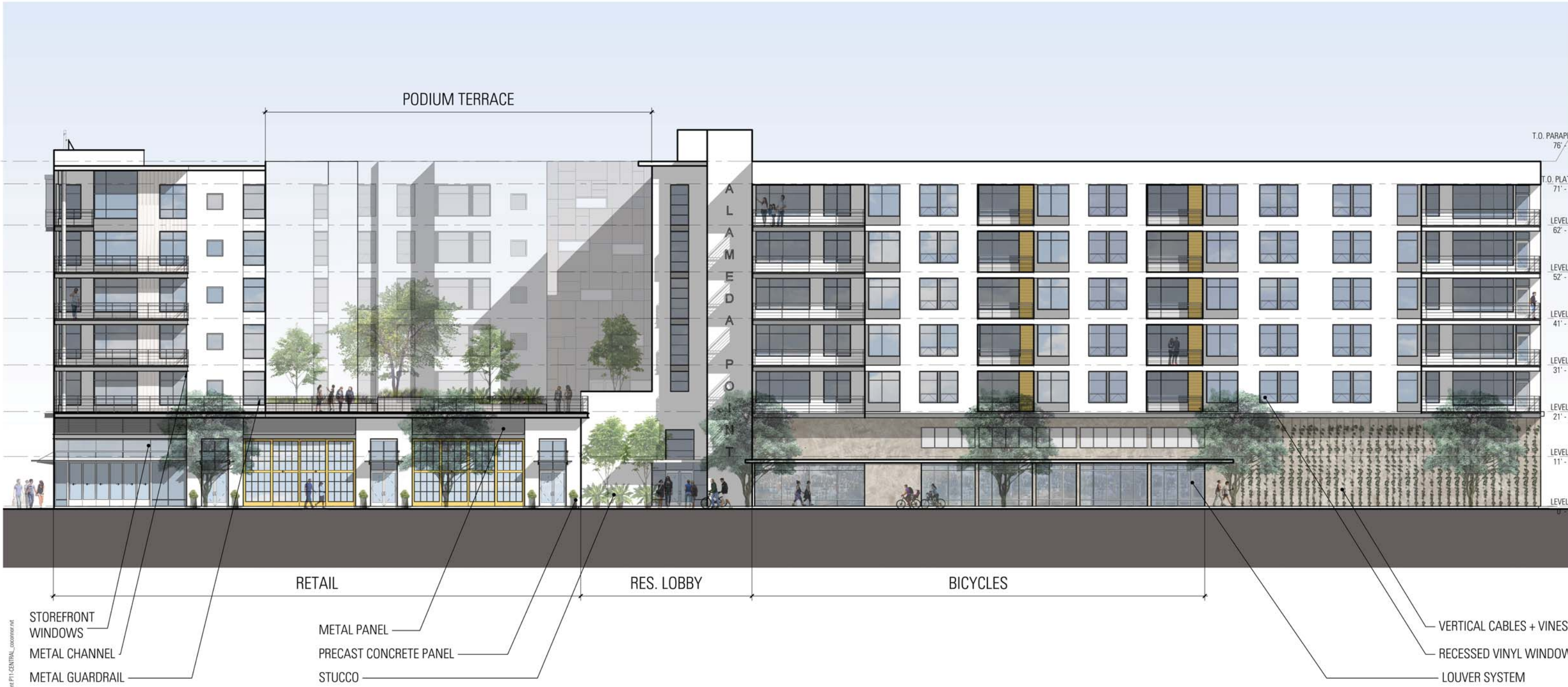

ALAMEDA POINT BLOCK 11 | ALAMEDA, CA

EAST ELEVATION



ALAMEDA POINT BLOCK 11 | ALAMEDA, CA

ENLARGED EAST ELEVATION + DESIGN REFERENCES



ALAMEDA POINT BLOCK 11 | ALAMEDA, CA

FERRY POINT WAY STREET VIEW



**WEST COURTYARD EXTERIOR ELEVATION -
LOOKING EAST AT COMMUNITY ROOM**
3
A3.4 3/32" = 1'-0"

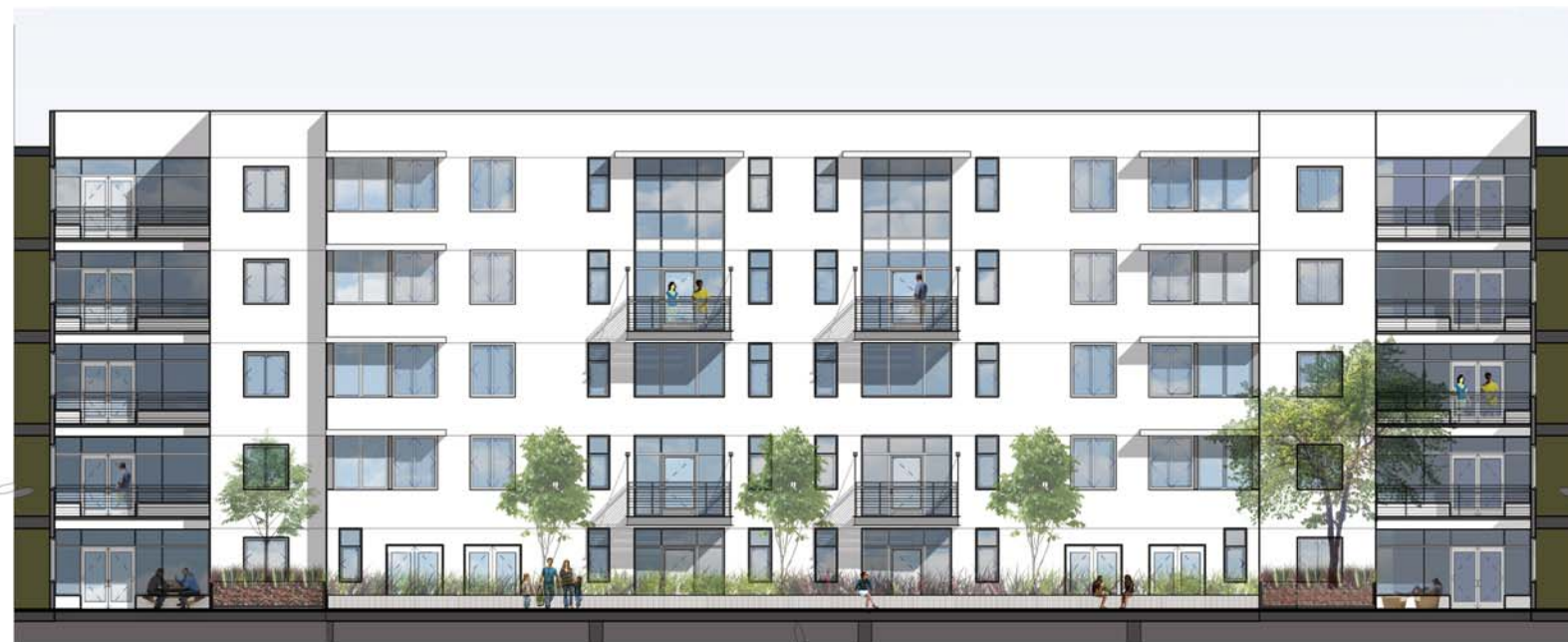

**WEST COURTYARD EXTERIOR ELEVATION -
LOOKING NORTH**
2
A3.4 3/32" = 1'-0"

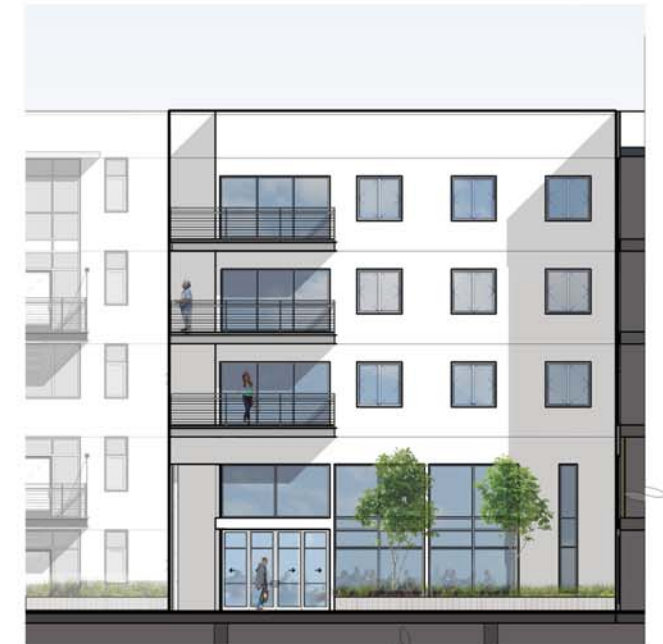

**WEST COURTYARD EXTERIOR ELEVATION -
LOOKING NORTH AT COMMUNITY ROOM**
1
A3.4 3/32" = 1'-0"

ALAMEDA POINT BLOCK 11 | ALAMEDA, CA

COURTYARD ELEVATIONS



**WEST COURTYARD EXTERIOR ELEVATION -
LOOKING WEST**

3
A3.5 3/32" = 1'-0"



**WEST COURTYARD EXTERIOR ELEVATION -
LOOKING SOUTH AT COMMUNITY ROOM**

2
A3.5 3/32" = 1'-0"



**WEST COURTYARD EXTERIOR ELEVATION -
LOOKING SOUTH**

1
A3.5 3/32" = 1'-0"

ALAMEDA POINT BLOCK 11 | ALAMEDA, CA

COURTYARD ELEVATIONS



**EAST COURTYARD EXTERIOR ELEVATION -
LOOKING SOUTH**

3
32 3/32" = 1'-0"



**EAST COURTYARD EXTERIOR ELEVATION -
LOOKING WEST**

2
32 3/32" = 1'-0"



**EAST COURTYARD EXTERIOR ELEVATION -
LOOKING NORTH**

1
32 3/32" = 1'-0"

1-CENTRAL_docomment

ALAMEDA POINT BLOCK 11 | ALAMEDA, CA

COURTYARD ELEVATIONS



ALAMEDA POINT BLOCK 11 | ALAMEDA, CA

VIEW OF COURTYARD TOWARD COMMUNITY ROOM



ALAMEDA POINT BLOCK 11 | ALAMEDA, CA

VIEW FROM NORTHWEST



ALAMEDA POINT BLOCK 11 | ALAMEDA, CA

VIEW FROM NORTHEAST

COPYRIGHT 2015

TOTAL UNIT MIX		
1 BED	61	28%
2 BED	119	54%
3 BED	40	18%
		220

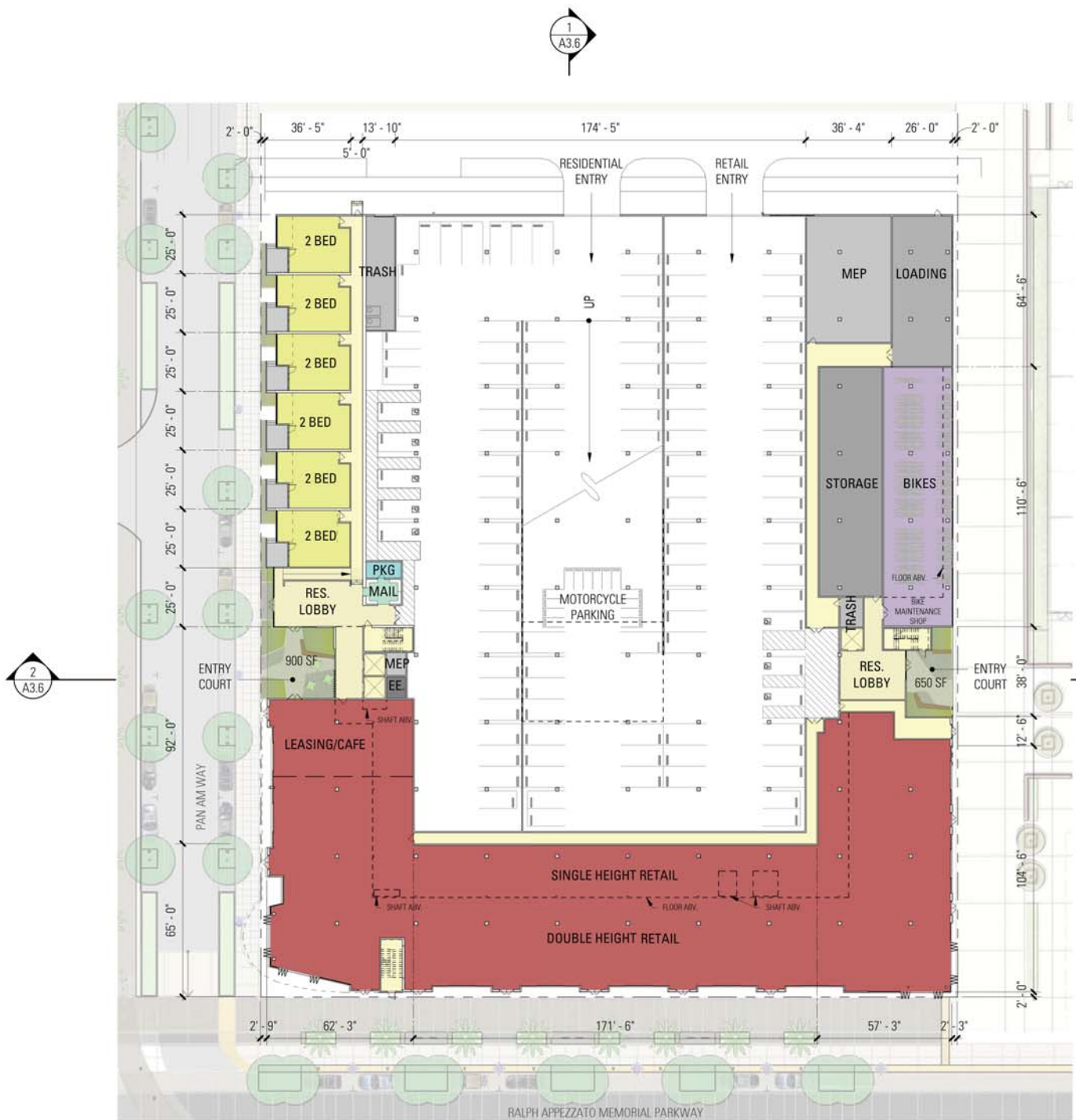

LEVEL 1
1/32" = 1'-0"

LEVEL 1	2 BED	6
		6

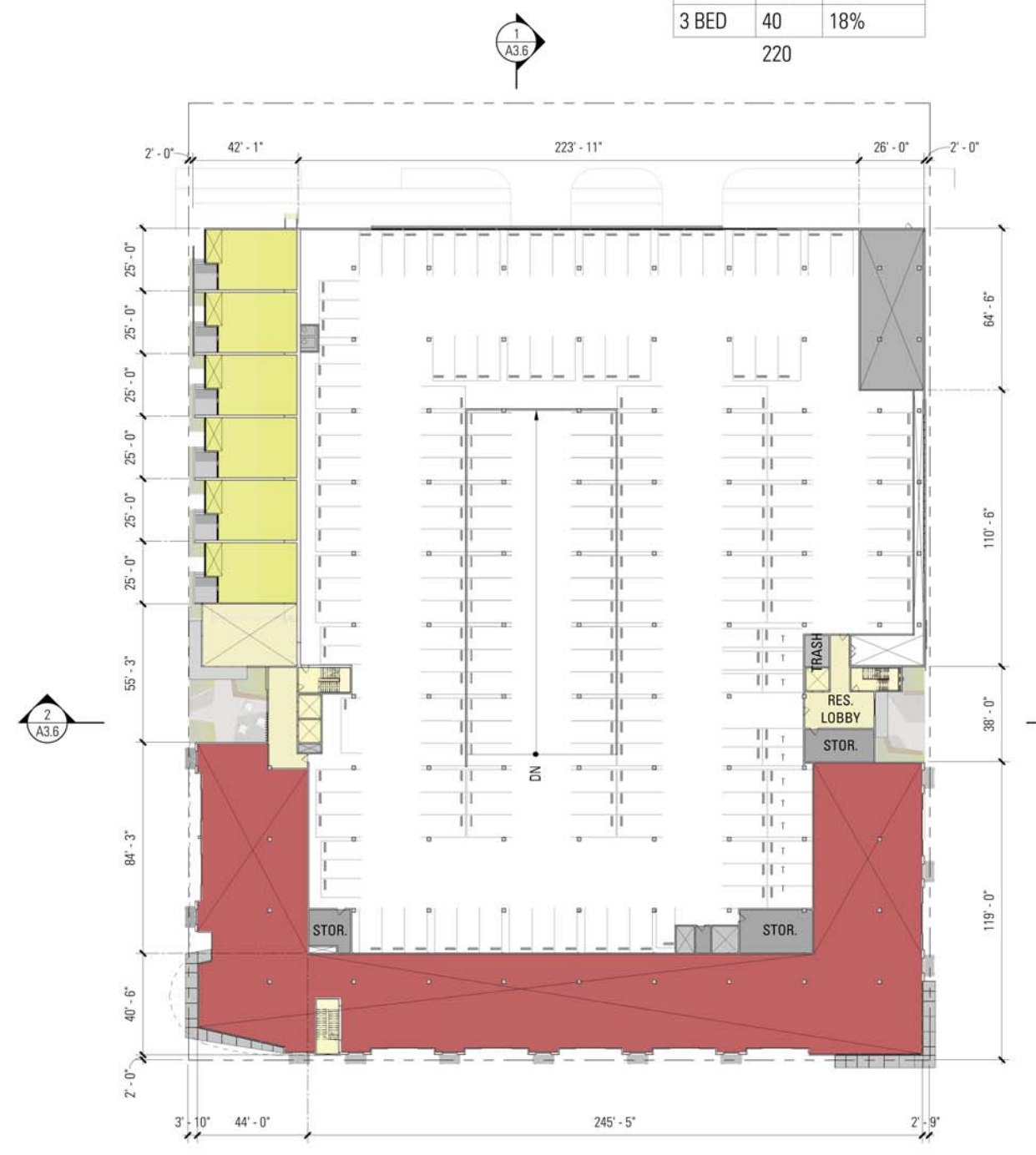

LEVEL 2
1/32" = 1'-0"

ALAMEDA POINT BLOCK 11 | ALAMEDA, CA

FLOOR PLANS



LEVEL 3
1/32" = 1'-0"

LEVEL 3	1 BED	12
LEVEL 3	2 BED	23
LEVEL 3	3 BED	7
		42

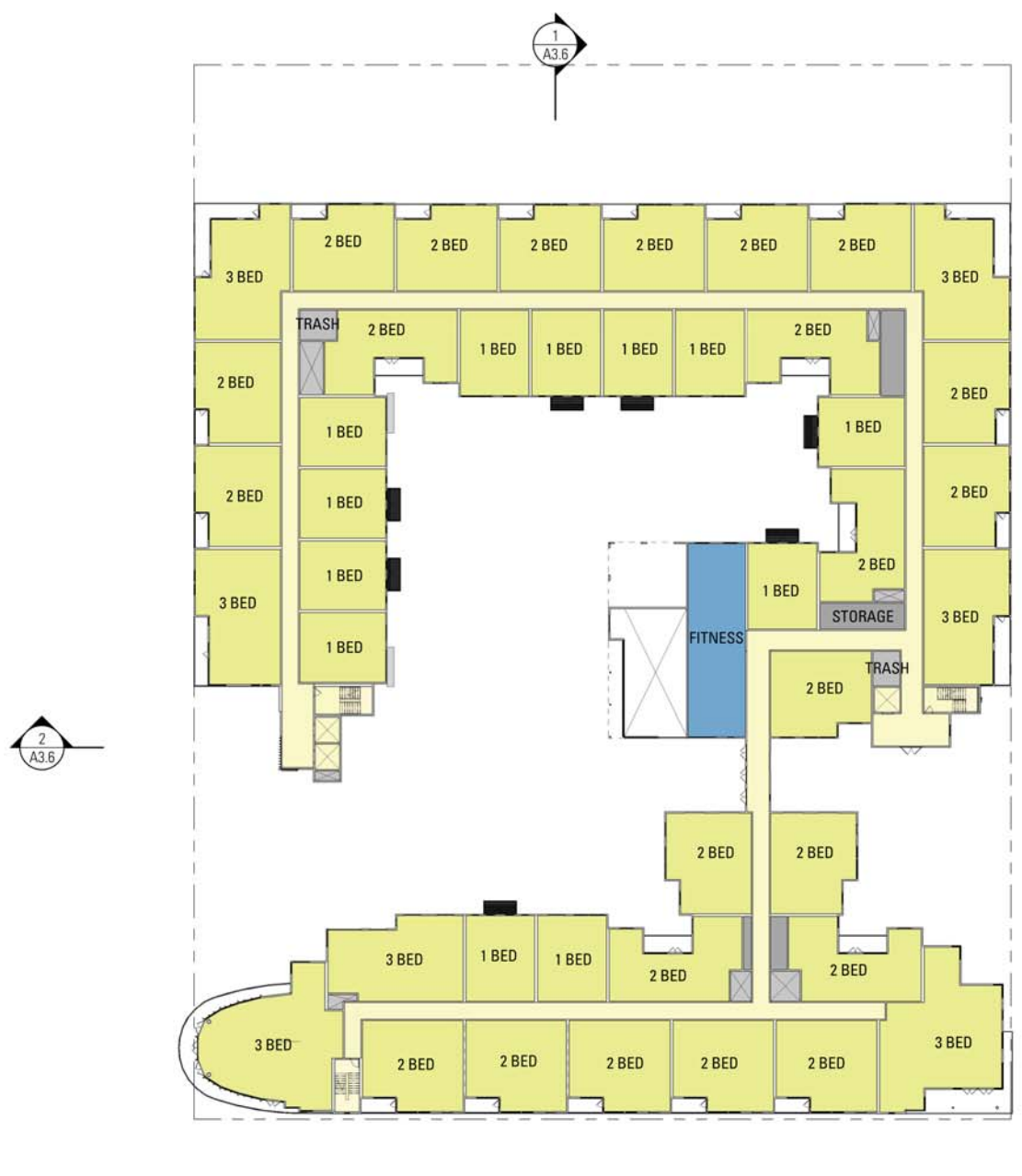

LEVEL 4
1/32" = 1'-0"

LEVEL 4	1 BED	12
LEVEL 4	2 BED	23
LEVEL 4	3 BED	7
		42

ALAMEDA POINT BLOCK 11 | ALAMEDA, CA

FLOOR PLANS

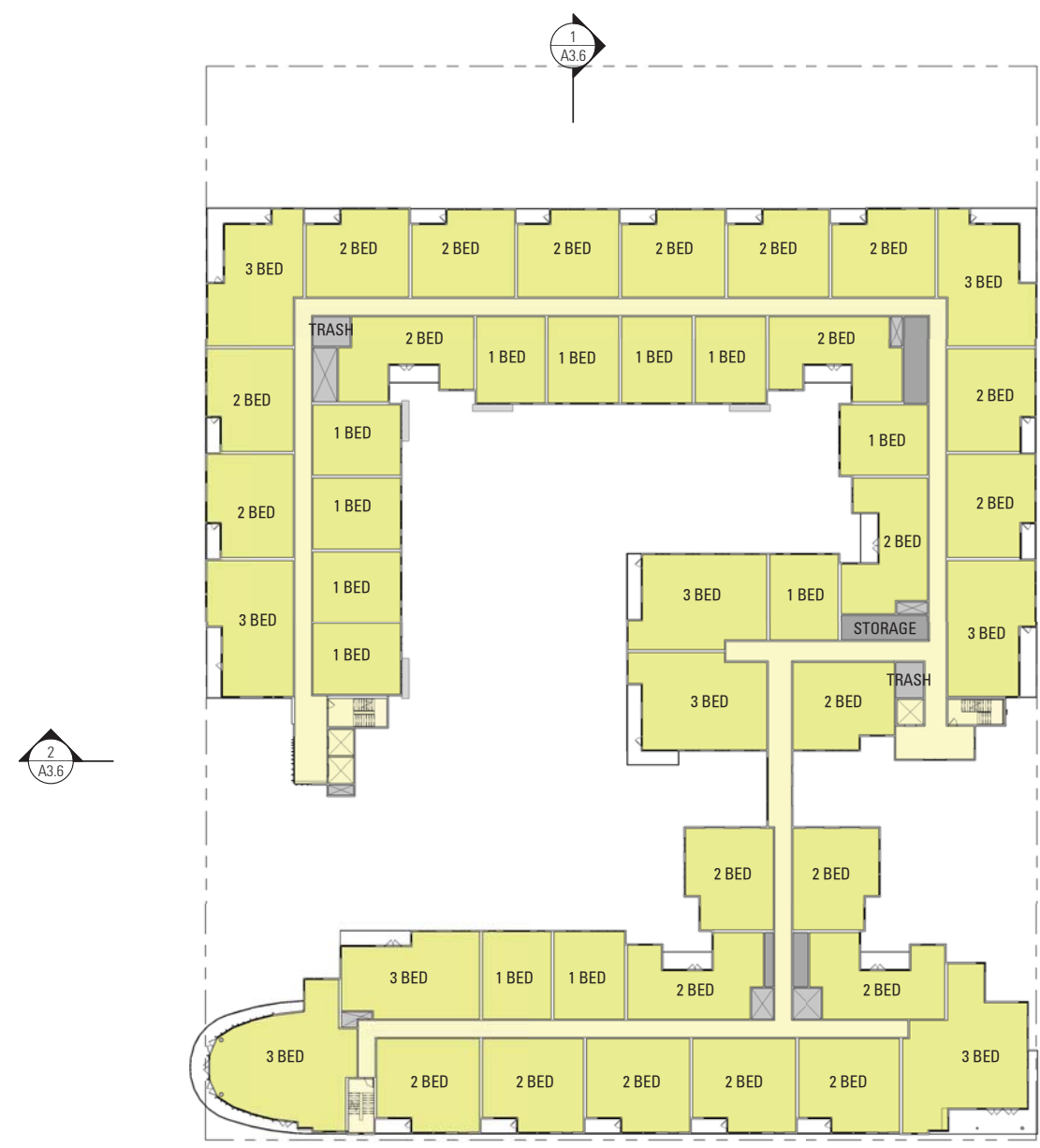

2
A3.6

LEVELS 5-6
1/32" = 1'-0"

LEVEL 5	1 BED	12	LEVEL 6	1 BED	12
LEVEL 5	2 BED	23	LEVEL 6	2 BED	23
LEVEL 5	3 BED	9	LEVEL 6	3 BED	9
		44			44



2
A3.6

LEVEL 7
1/32" = 1'-0"

LEVEL 7	1 BED	13
LEVEL 7	2 BED	21
LEVEL 7	3 BED	8
		42

ALAMEDA POINT BLOCK 11 | ALAMEDA, CA

FLOOR PLANS

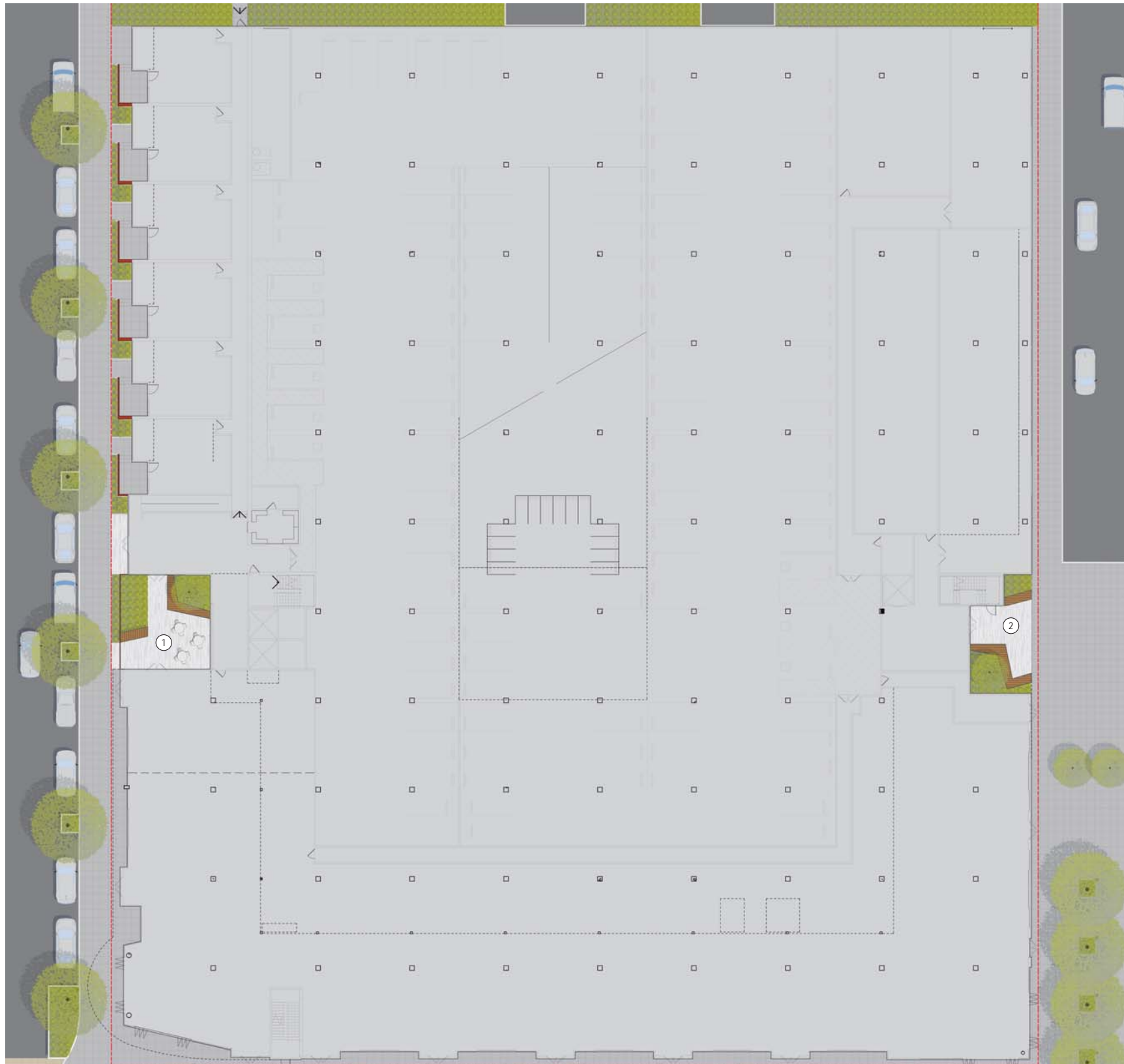

ENTRY GARDENS



FRONT COURTYARD



PLANTING ALONG FACADE



RAISED CONCRETE PLANTER WITH BUILT IN SEATING

KEY NOTES

- ① COURTYARD WITH CAFE SEATING AND WOOD BENCHES
- ② PUBLIC ENTRY GARDEN WITH WOOD BENCHES

ALAMEDA POINT BLOCK 11 | ALAMEDA, CA

LANDSCAPE SITE PLAN - LEVEL 1



COMMUNITY POOL AREA



COMMUNITY KITCHEN & STEEL PERGOLA

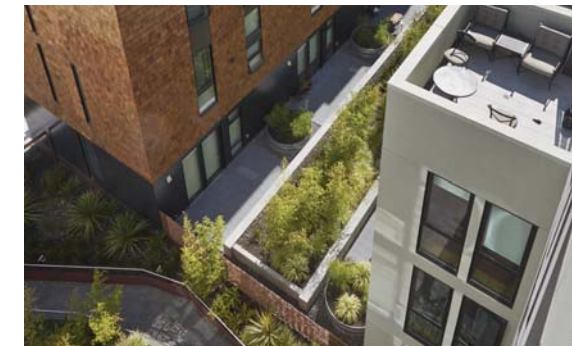

PRIVATE UNIT PATIOS & RAISED CONCRETE PLANTERS

KEY NOTES

- ① SWIMMING POOL ON RAISED POOL DECK
- ② SHADED LOUNGE AREA
- ③ PRIVATE UNIT PATIO
- ④ SHADED OUTDOOR KITCHEN WITH BBQ & COMMUNITY TABLE
- ⑤ RAISED CONCRETE PLANTER
- ⑥ WOOD BENCH
- ⑦ SEATING AREA WITH MOVEABLE FURNITURE
- ⑧ FLEX SPACE WITH OVERHEAD STRING LIGHTS

ALAMEDA POINT BLOCK 11 | ALAMEDA, CA

LANDSCAPE SITE PLAN - LEVEL 3

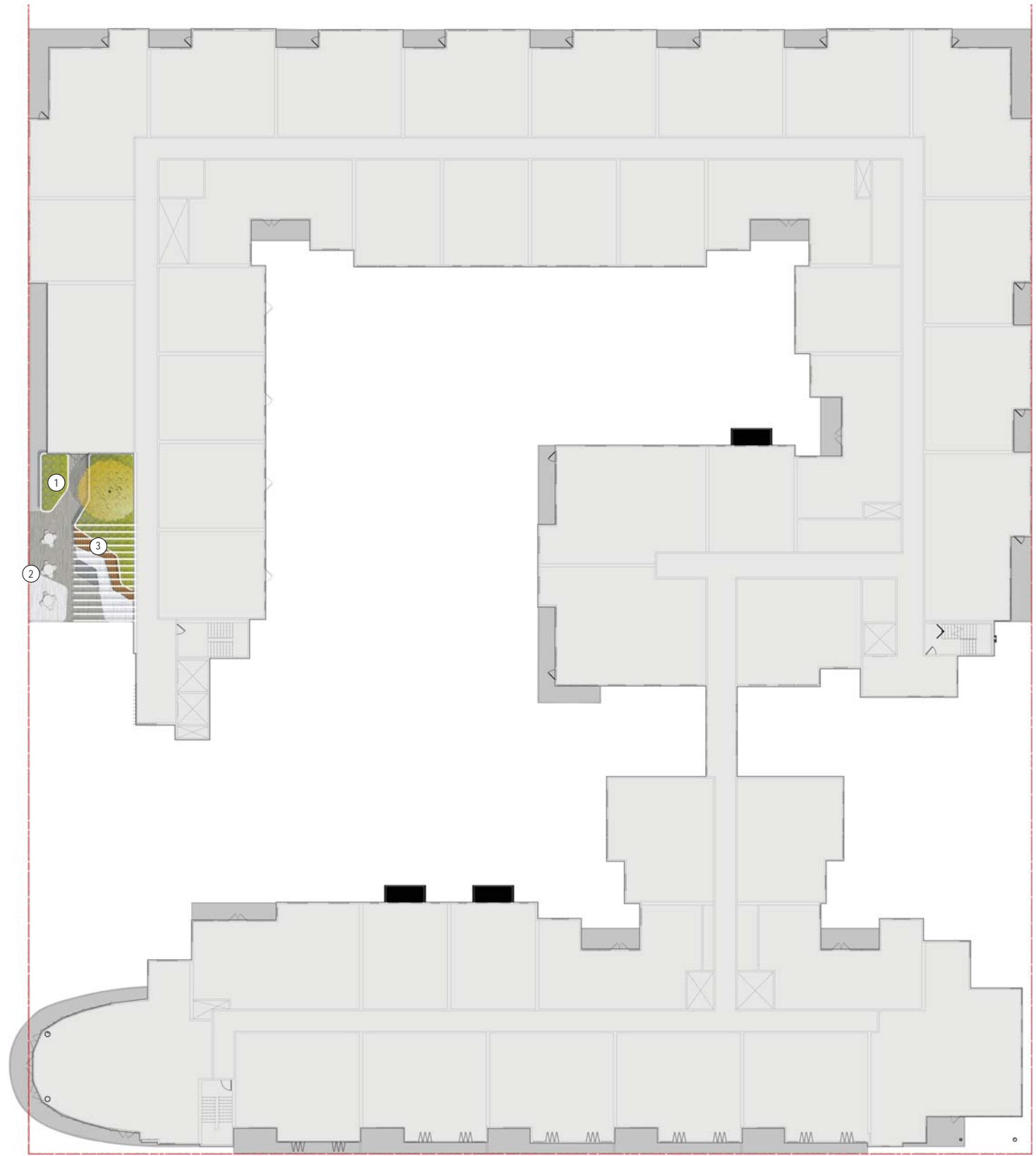

SEATING NOOK

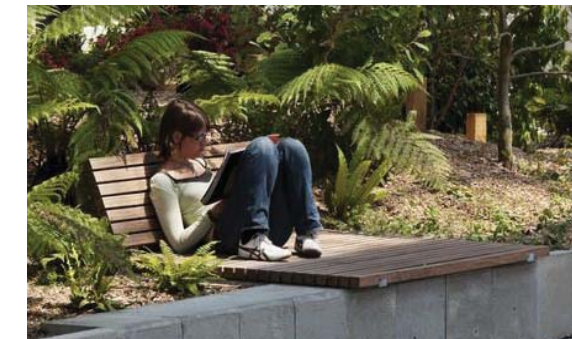

SEATING NOOK WITH WOOD BENCHES



CAFE SEATING & RAISED CONCRETE PLANTERS

KEY NOTES

- ① RAISED CONCRETE PLANTER
- ② SEATING AREA WITH MOVEABLE FURNITURE
- ③ SHADED WOOD BENCH SEATING AREA WITH FIRE PIT

ALAMEDA POINT BLOCK 11 | ALAMEDA, CA

LANDSCAPE SITE PLAN - LEVEL 7

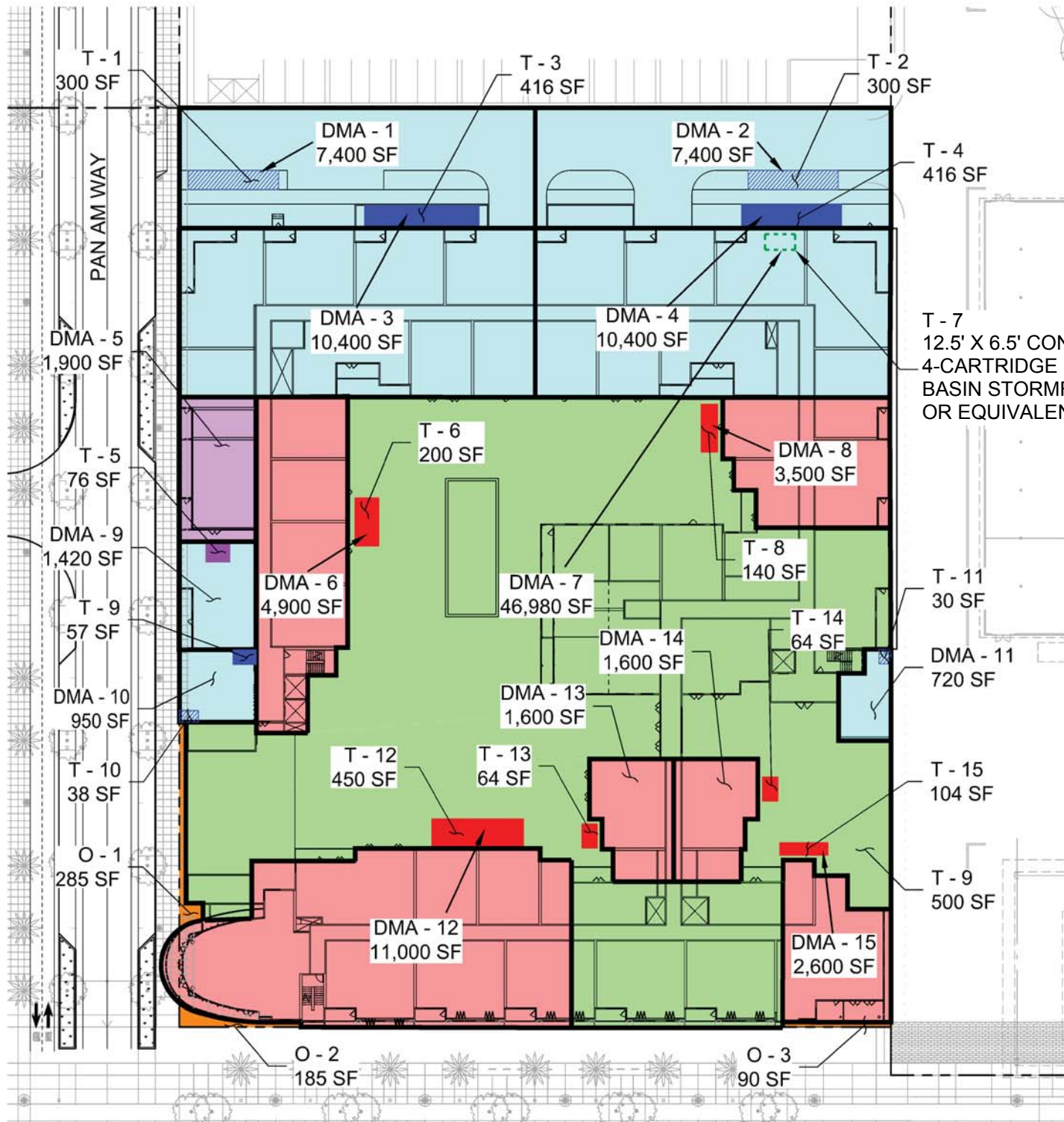

RALPH APPEZZATO MEMORIAL PARKWAY

NOTES:

- TREATMENT AREA PRELIMINARILY SIZED USING 4% CORRESPONDING DMA.
- TRASH CAPTURE AND COMPLIANCE WITH C.10 WILL BE PART OF THE ALAMEDA POINT SITE A STORMWATER OUTFALL IMPROVEMENTS.
- AREA DRAINING TO OFFSITE TREATMENT TO BE TREATED IN BIORETENTION AREAS WITHIN PUBLIC RIGHT-OF-WAY ADJACENT TO BUILDING.

ABBREVIATIONS

BIO	BIORETENTION AREA
DMA	DRAINAGE MANAGEMENT AREA
FTP	FLOW-THROUGH PLANTER
S.F.	SQUARE FEET
T	TREATMENT AREA
O	AREA TO BE TREATED BY OFFSITE BIORETENTION

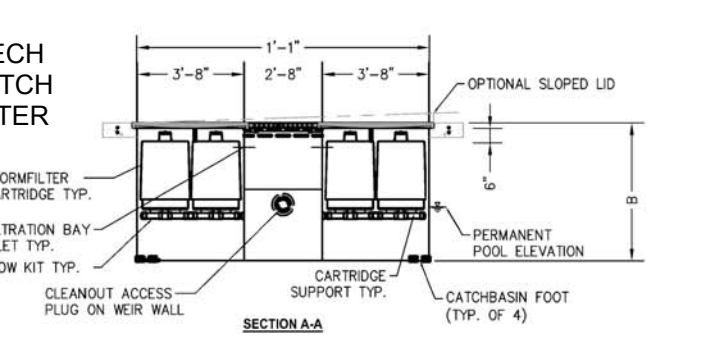
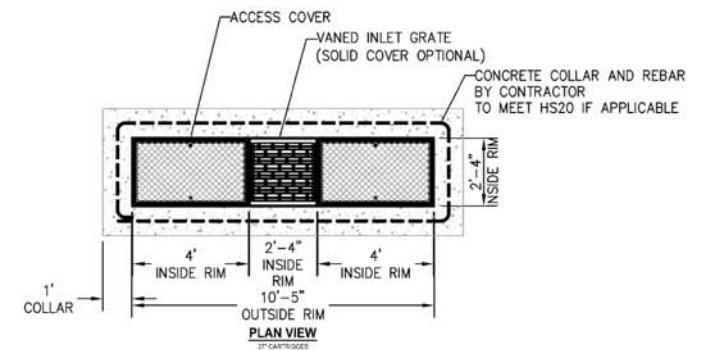

1 STORMWATER FILTER
NTS

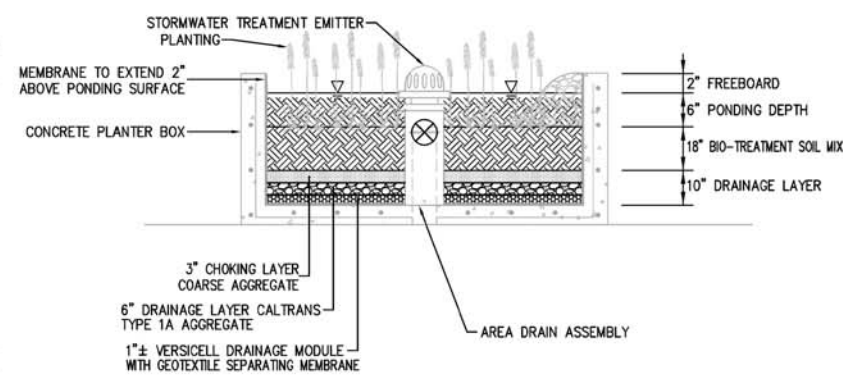

2 FLOW-THROUGH PLANTER (LEVEL 1)
NTS

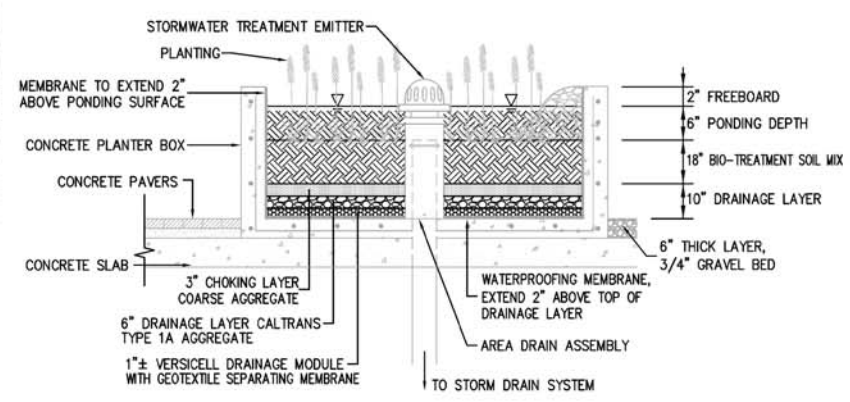

4 FLOW-THROUGH PLANTER (LEVEL 3 AND 7)
NTS

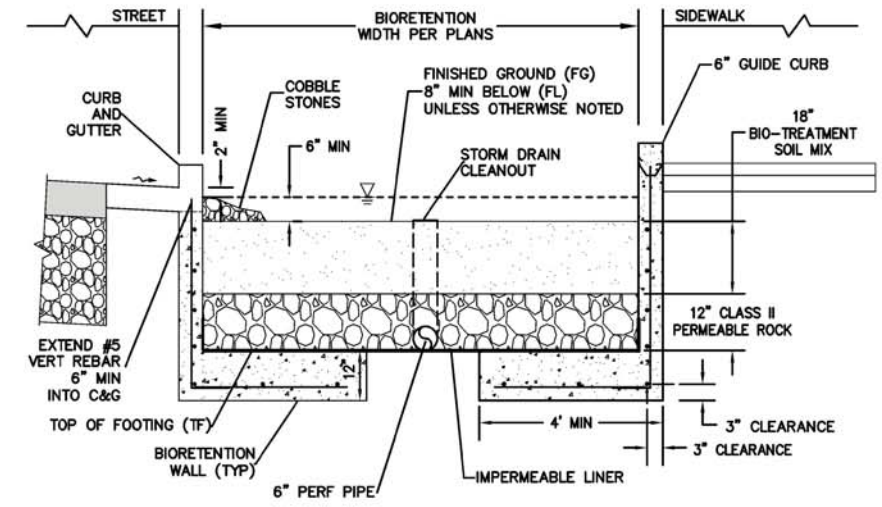

3 BIORETENTION AREA (STRUCTURED)
NTS

SHED	SHED AREA (S.F.)	TREATMENT AREA		TREATMENT MEASURE
		REQUIRED (S.F.)	PROVIDED (S.F.)	
DMA-1	7400	296	300	BIO
DMA-2	7400	296	300	BIO
DMA-3	10400	416	420	FTP
DMA-4	10400	416	420	FTP
DMA-5	1900	76	80	BIO
DMA-6	4900	196	200	BIO
DMA-7	46980	-	-	MF
DMA-8	3500	140	140	FTP
DMA-9	1420	57	60	FTP
DMA-10	950	38	40	FTP
DMA-11	720	29	30	BIO
DMA-12	11000	440	440	FTP
DMA-13	1600	64	70	FTP
DMA-14	1600	64	70	FTP
DMA-15	2600	104	110	FTP

LEGEND:

- DMA TO BE TREATED ON LEVEL 1 BY BIORETENTION AREAS/FLOW-THROUGH PLANTERS
- DMA TO BE TREATED ON LEVEL 1 BY MEDIA FILTER
- DMA TO BE TREATED ON LEVEL 3 BY FLOW-THROUGH PLANTERS
- DMA TO BE TREATED ON LEVEL 7 BY FLOW-THROUGH PLANTERS
- BIORETENTION AREA ON LEVEL 1
- FLOW-THROUGH PLANTER ON LEVEL 1
- MEDIA FILTER ON LEVEL 1
- FLOW-THROUGH PLANTER ON LEVEL 3
- FLOW-THROUGH PLANTER ON LEVEL 7
- OFFSITE STREET TREATMENT-X

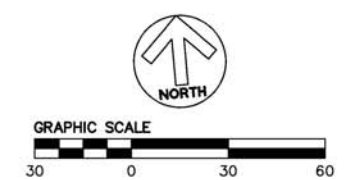

ALAMEDA POINT BLOCK 11 | ALAMEDA, CA

PRELIMINARY STORMWATER MANAGEMENT PLAN

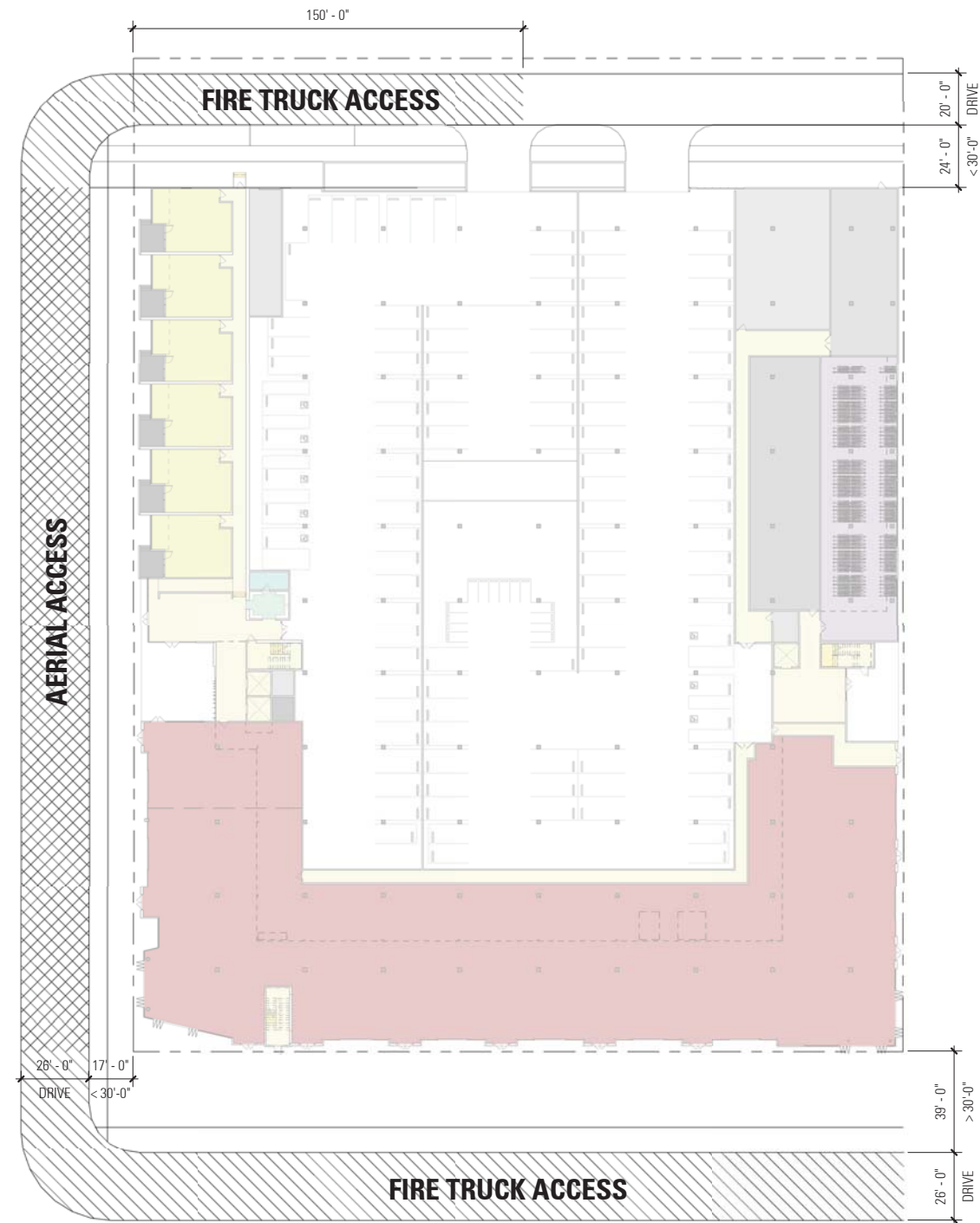

1
38
LEVEL 1 - FIRE ACCESS DIAGRAM
1/32" = 1'-0"

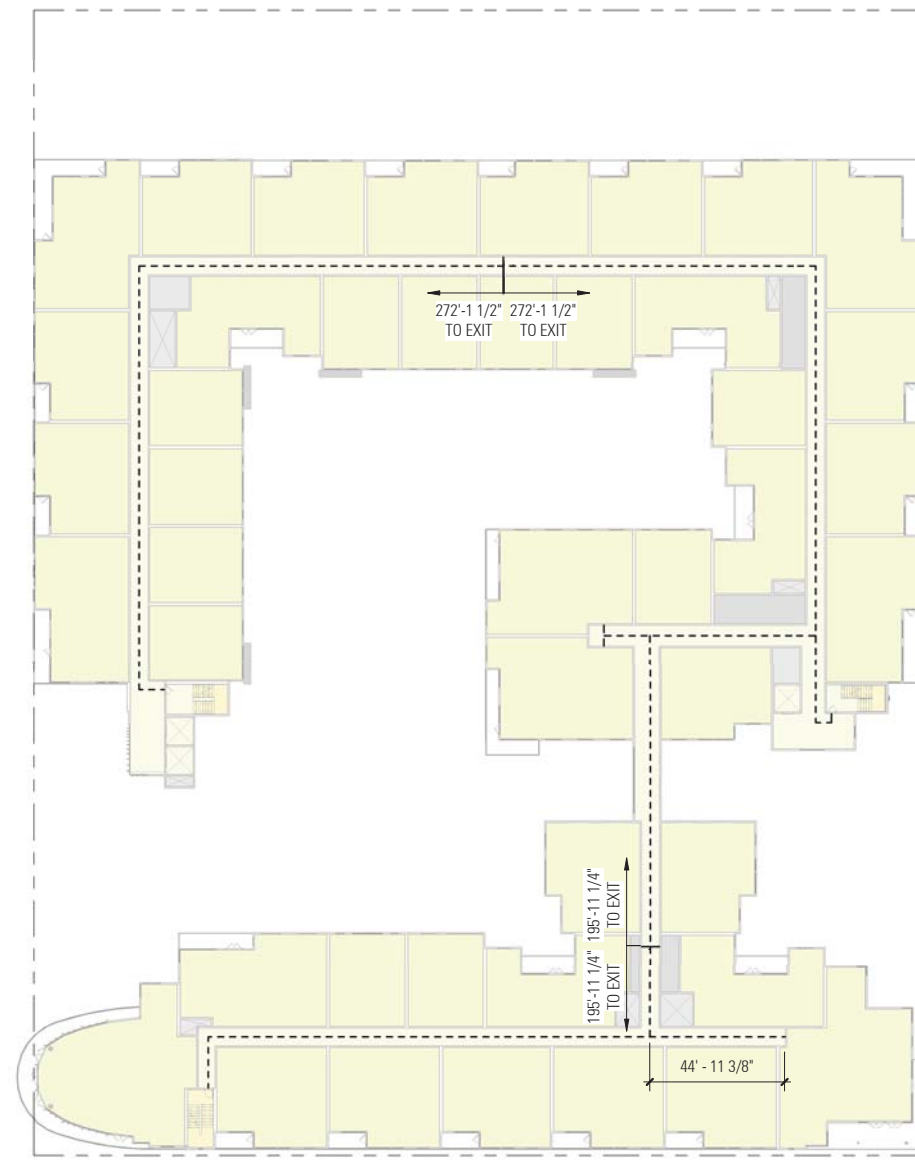

2
38
RESIDENTIAL EGRESS DIAGRAM
1/32" = 1'-0"

ALAMEDA POINT BLOCK 11 | ALAMEDA, CA

LIFE SAFETY DIAGRAMS



ALAMEDA POINT BLOCK 11 | ALAMEDA, CA

VIEW FROM WATERFRONT

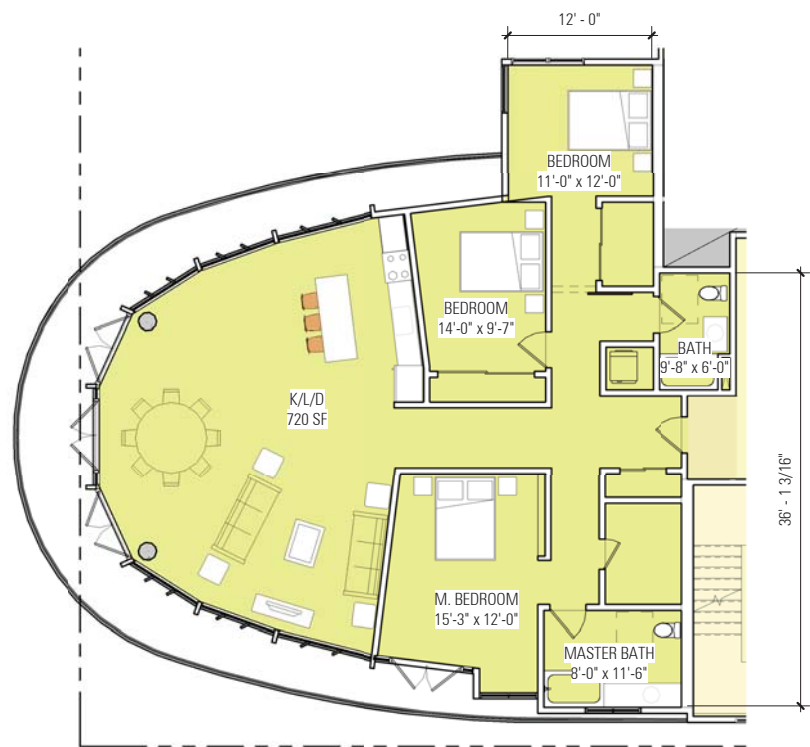

4
19
3 BEDROOM - SOUTHWEST
1/8" = 1'-0"

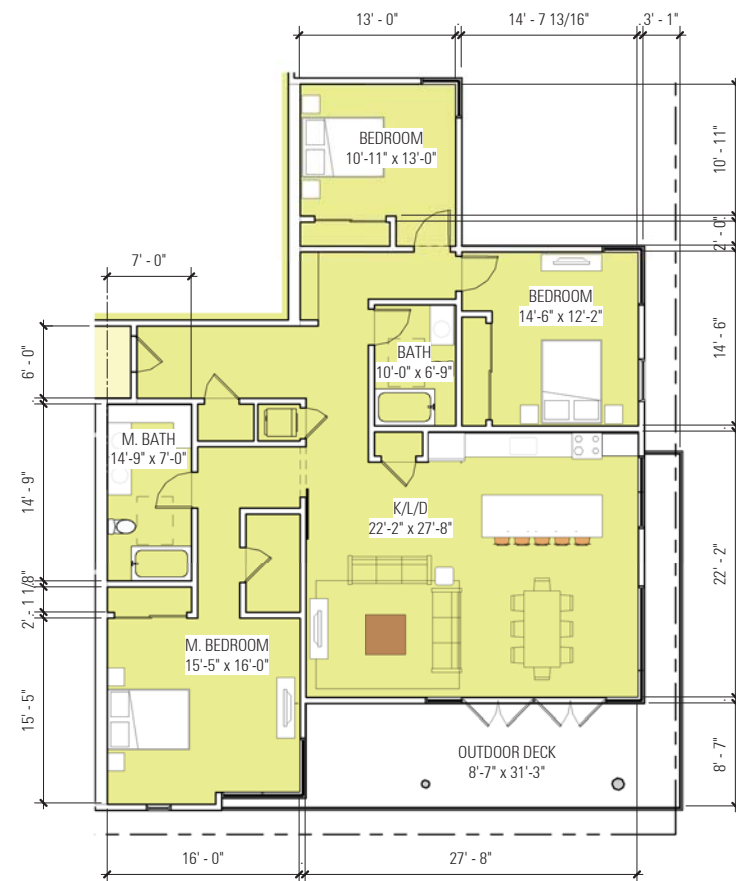

3
19
3 BEDROOM - SOUTHEAST
1/8" = 1'-0"

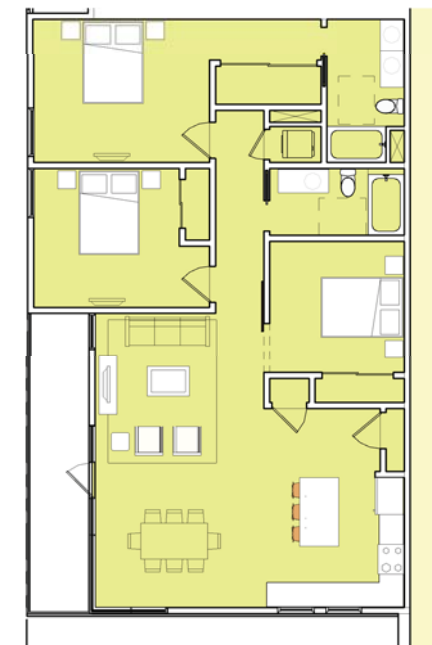

2
19
3 BEDROOM - TYP.
1/8" = 1'-0"

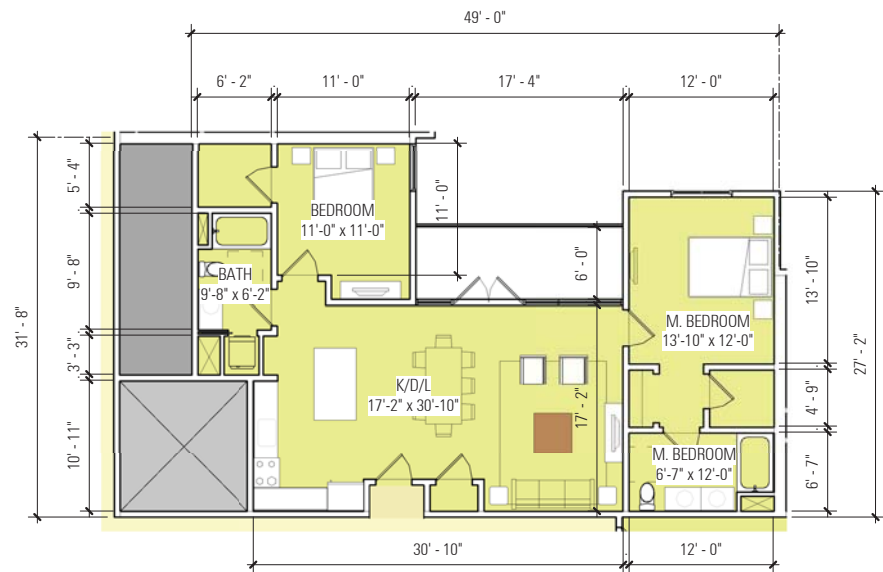

8
19
2 BEDROOM - INSIDE CORNER
1/8" = 1'-0"

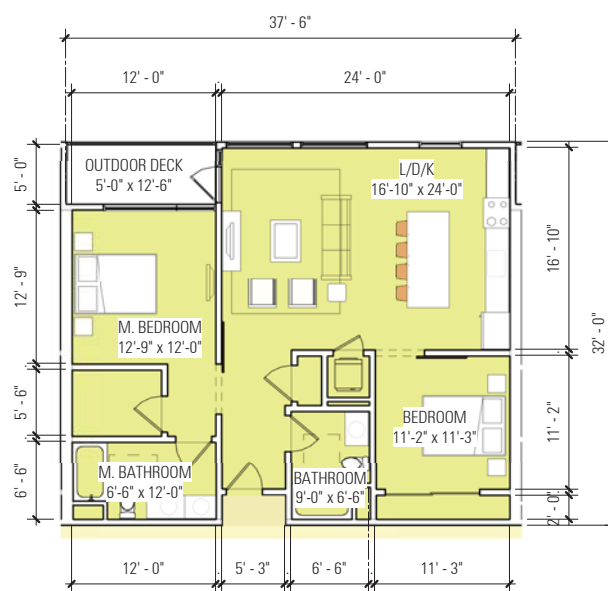

7
19
2 BEDROOM - TYP.
1/8" = 1'-0"



1
19
1 BEDROOM - TYP. 2
1/8" = 1'-0"

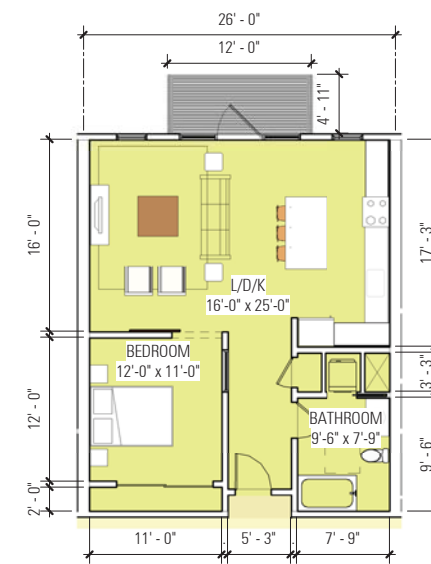

6
19
1 BEDROOM - TYP.
1/8" = 1'-0"

ALAMEDA POINT BLOCK 11 | ALAMEDA, CA

UNIT PLANS